



## SB/ESB SERIES

### THERMAL PROTECTORS

### Introduction

The SB/ESB Series thermal protector offers the reliability of a bimetal protector in a robust hermetic package. It is ideally suited to provide thermal and/or locked rotor protection in applications requiring unique processing or environmental challenges (AC/DC motors, compressors, transformers, etc.).

With an exceptional history of more than 90 years, Sensata Technologies is a leading supplier of sensors and switches.

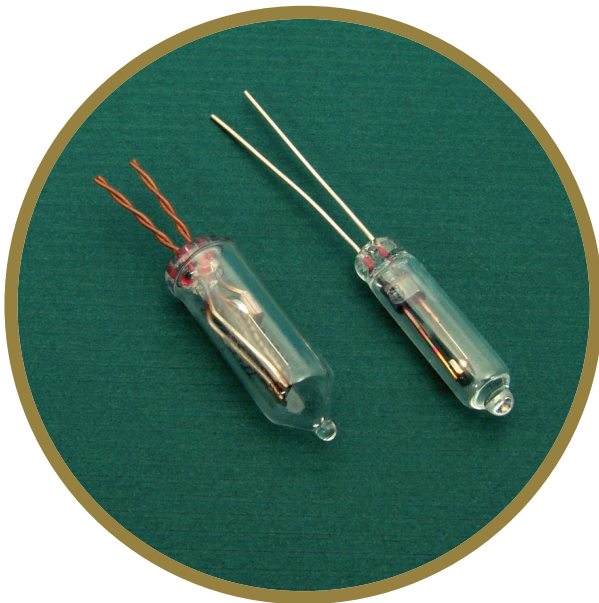

### Features

- Hermetically sealed
- Compact
- Opening temperature range of 60°C to 170°C in 5°C increments
- Snap action
- Copper or tin plated copper leads in a variety of lengths

### Benefits

- Safe from penetration of fluids
- Ultimate corrosion protection
- No secondary insulation needed
- Can operate in high pressure environments
- Improves safety of end product

Sensata Technologies' miniature, glass encapsulated thermal protectors provide both thermal and current overload protection.

The SB/ESB family of protectors combines Sensata's bimetal protection technology with a true glass to metal hermetic seal. This ultra-reliable combination can be used for such things as small AC fractional horsepower motors, DC motors, battery chargers, ballasts, NiCad battery packs, transformers and internal protection for compressors.

Sensata Technologies is an ISO and TS registered company providing world class quality products.

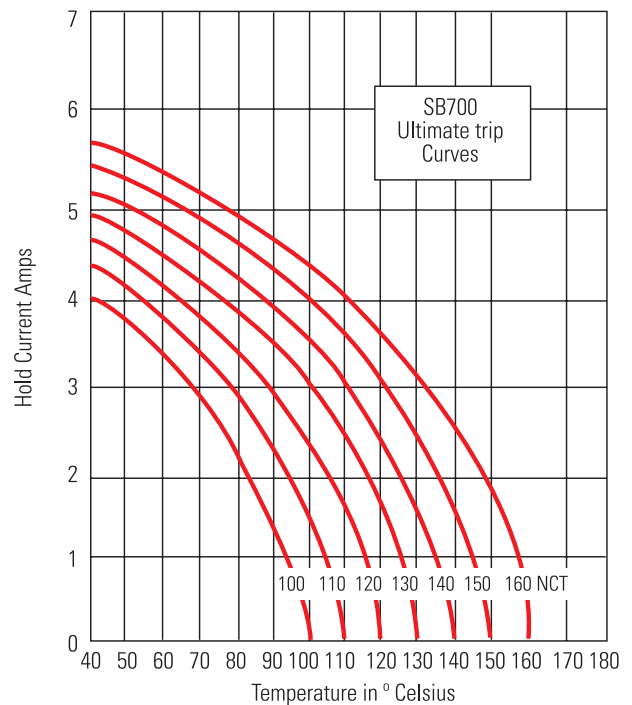
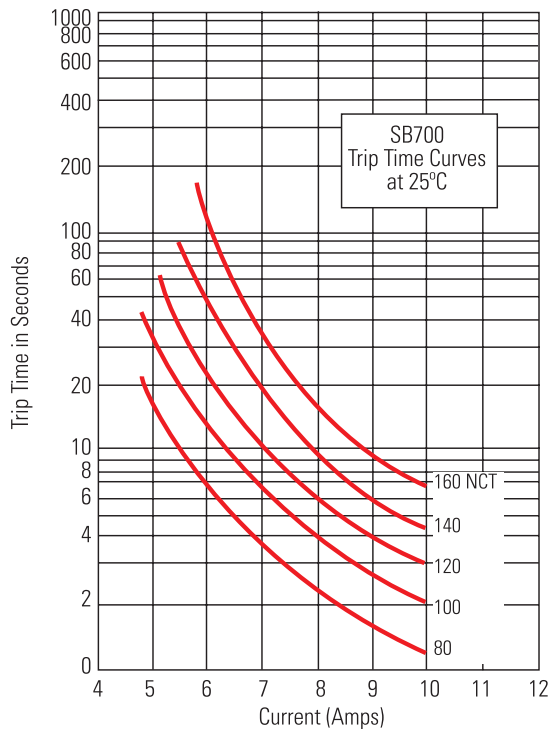
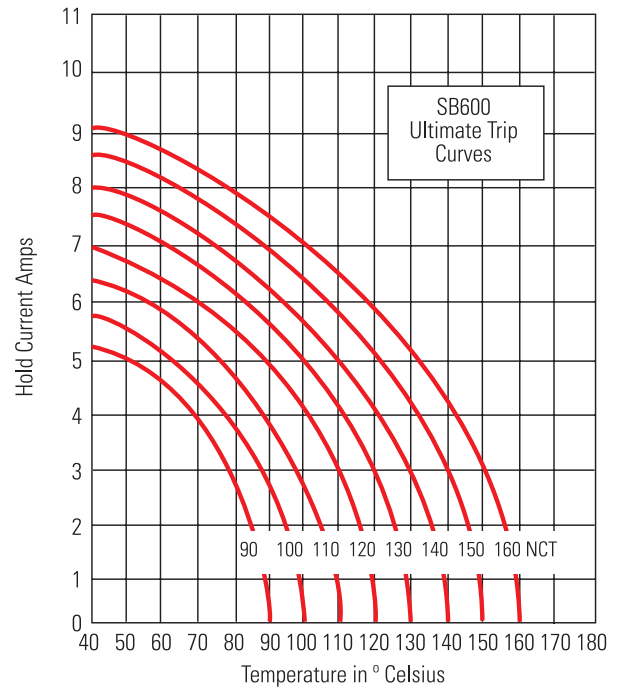
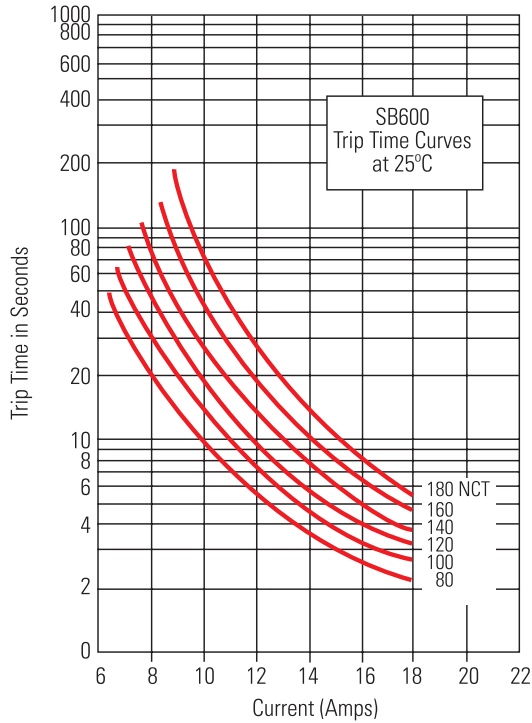

These curves are to be used only as a guide in selecting a protector for a particular application. Factors such as distance from the heat source and the method of mounting should be considered in selecting a protector. Final trip times are dependent upon terminal configuration and mounting in the application

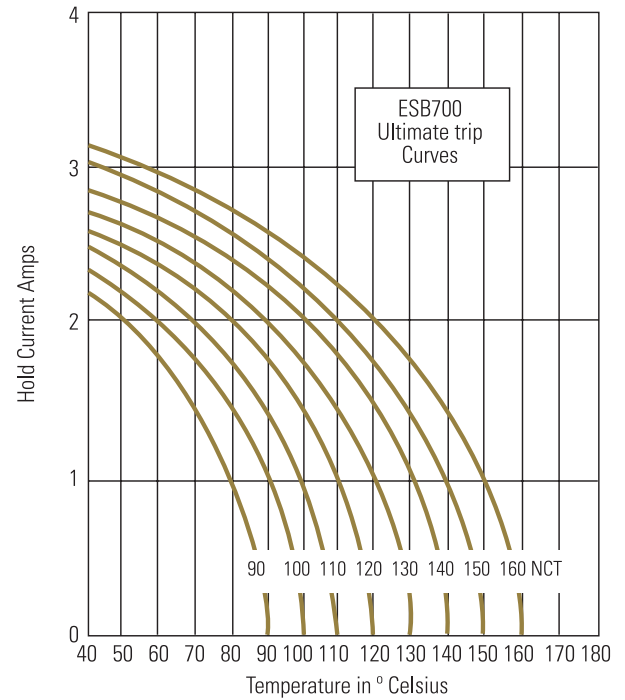
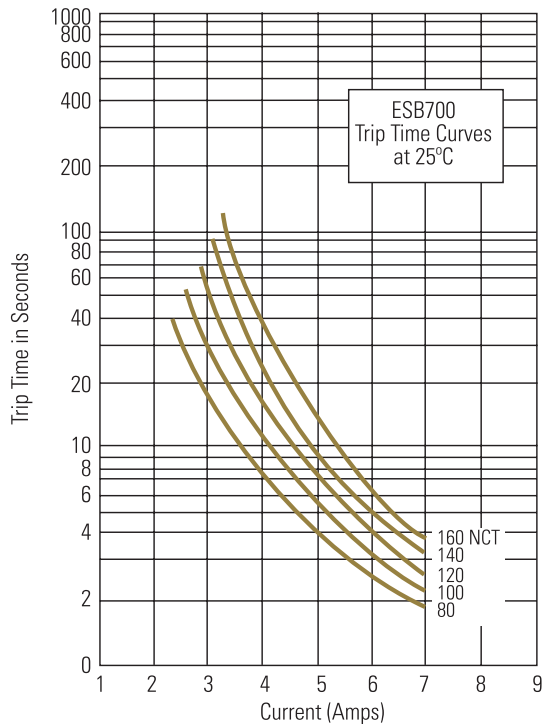

These curves are to be used only as a guide in selecting a protector for a particular application. Factors such as distance from the heat source and the method of mounting should be considered in selecting a protector. Final trip times are dependent upon terminal configuration and mounting in the application



## GLOBAL SALES OFFICES

### North America

Sensata Technologies, Inc.  
Electrical Protection  
529 Pleasant Street, MS B-49  
Attleboro, Massachusetts 02703  
Phone: 1-508-236-3287

### Central & South America

Sensata Technologies Sensores e  
Controles Do Brasil LTDA.  
Rua Azarias de Melo, 648  
Bairro Taquaral-Campinas/SP  
Brasil  
Phone: 19-3754-1142

### Europe

Sensata Technologies Holland B.V.  
Jan Tinbergenstraat 80  
7559 SP Hengelo  
The Netherlands  
Phone: +31 74 357 8000

### Middle East & India

Sensata Technologies India Pvt. Ltd.  
Bagmane Tech Park  
Byrasandra CV Raman Nagar  
Bangalore-560 093  
India  
Phone: 91-25-099329

### Asia

Sensata Technologies (Shanghai) Co., Ltd.  
Novel Plaza, 8th Floor  
128 Nanjing Road  
West Huangpu District  
Shanghai 200003, PRC  
Phone: 86-21-23061553



## DIMENSIONS

All dimensions are in millimeters (Inches).

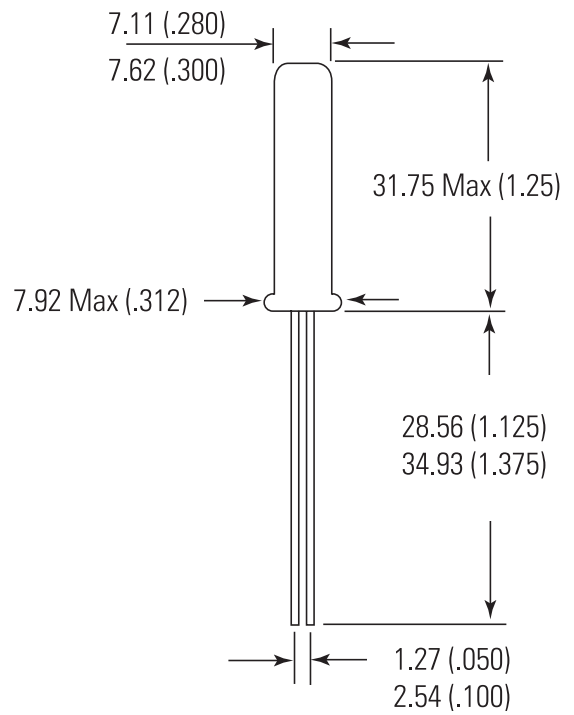
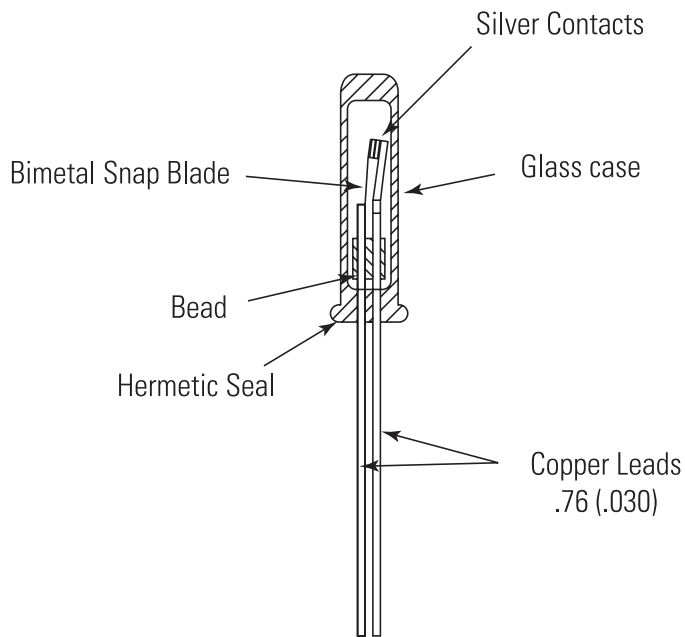



## AGENCY APPROVALS & CERTIFICATIONS



Agency	
<b>BEAB</b>	EN60730-2-1, EN60730-2-2 Open Motors (BEAB-CRC 0004)
<b>IEC</b>	730-2-4 Compressor Motors
<b>UL / C-UL</b>	Files E37501 & E28135, UL Nos. 547 & 873 IEC 730-2-2 Open Motors
<b>CSA</b>	File LR 20529, C22.2 Nos. 77 & 24



## WARNINGS



### RISK OF MATERIAL DAMAGE AND HOT ENCLOSURE

- The product's side panels may be hot, allow the product to cool before touching
- Follow proper mounting instructions including torque values
- Do not allow liquids or foreign objects to enter this product

**Failure to follow these instructions can result in serious injury, or equipment damage.**



### HAZARD OF ELECTRIC SHOCK, EXPLOSION OR ARC FLASH

- Disconnect all power before installing or working with this equipment
- Verify all connections and replace all covers before turning on power

**Failure to follow these instructions will result in death or serious injury**

Sensata Technologies, Inc. ("Sensata") data sheets are solely intended to assist designers ("Buyers") who are developing systems that incorporate Sensata products (also referred to herein as "components"). Buyer understands and agrees that Buyer remains responsible for using its independent analysis, evaluation and judgment in designing Buyer's systems and products. Sensata data sheets have been created using standard laboratory conditions and engineering practices. Sensata has not conducted any testing other than that specifically described in the published documentation for a particular data sheet. Sensata may make corrections, enhancements, improvements and other changes to its data sheets or components without notice.

Buyers are authorized to use Sensata data sheets with the Sensata component(s) identified in each particular data sheet. HOWEVER, NO OTHER LICENSE, EXPRESS OR IMPLIED, BY ESTOPPEL OR OTHERWISE TO ANY OTHER SENSATA INTELLECTUAL PROPERTY RIGHT, AND NO LICENSE TO ANY THIRD PARTY TECHNOLOGY OR INTELLECTUAL PROPERTY RIGHT, IS GRANTED HEREIN. SENSATA DATA SHEETS ARE PROVIDED "AS IS". SENSATA MAKES NO WARRANTIES OR REPRESENTATIONS WITH REGARD TO THE DATA SHEETS OR USE OF THE DATA SHEETS, EXPRESS, IMPLIED OR STATUTORY, INCLUDING ACCURACY OR COMPLETENESS. SENSATA DISCLAIMS ANY WARRANTY OF TITLE AND ANY IMPLIED WARRANTIES OF MERCHANTABILITY, FITNESS FOR A PARTICULAR PURPOSE, QUIET ENJOYMENT, QUIET POSSESSION, AND NON-INFRINGEMENT OF ANY THIRD PARTY INTELLECTUAL PROPERTY RIGHTS WITH REGARD TO SENSATA DATA SHEETS OR USE THEREOF.

All products are sold subject to Sensata's terms and conditions of sale supplied at [www.sensata.com](http://www.sensata.com) SENSATA ASSUMES NO LIABILITY FOR APPLICATIONS ASSISTANCE OR THE DESIGN OF BUYERS' PRODUCTS. BUYER ACKNOWLEDGES AND AGREES THAT IT IS SOLELY RESPONSIBLE FOR COMPLIANCE WITH ALL LEGAL, REGULATORY AND SAFETY-RELATED REQUIREMENTS CONCERNING ITS PRODUCTS, AND ANY USE OF SENSATA COMPONENTS IN ITS APPLICATIONS, NOTWITHSTANDING ANY APPLICATIONS-RELATED INFORMATION OR SUPPORT THAT MAY BE PROVIDED BY SENSATA.

Mailing Address: Sensata Technologies, Inc., 529 Pleasant Street, Attleboro, MA 02703, USA.

## CONTACT US

### Americas

+1 (508) 236 2551  
electrical-protection-sales@  
sensata.com

### Europe, Middle East & Africa

+3 (174) 357 8156  
info-sse@list.sensata.com

### Asia Pacific

sales.isasia@list.sensata.com  
China +86 (21) 2306 1500  
Japan +81 (45) 277 7117  
Korea +82 (31) 601 2004  
India +91 (80) 67920890  
Rest of Asia +886 (2) 27602006  
ext 2808