



# Sensata Technologies

## 20TC SERIES



Autorisierter Distributor:

**Neumüller Elektronik GmbH** | Gewerbegebiet Ost 7 | D-91085 Weisendorf  
Tel. +49 9135 73666-0 | [info@neumueller.com](mailto:info@neumueller.com) | [www.neumueller.com](http://www.neumueller.com)



## | 20TC SERIES

Single-Phase, Switchable On/Off, Rocker-Type Actuator

### Introduction

Klixon® 20TC series circuit breakers offer the advantages of integrating an on/off switch and a circuit protector in a trim, compact package.

The snap-on actuators are available on request in a variety of colors, styles and indication markings designed to provide a stylish console appearance to the panels of light aircraft.



Several different types of actuators are available. The translucent actuator permits quick identification of the actuator position under low ambient lighting conditions by emitting a soft glow from a light source, such as an edge-lighted panel. Colored actuators will be hot letter stamped in white. White and translucent actuators will be stamped in black.

### Features

- Versatile rocker actuator: snap-on, switch type
- Various styles and colors (black, white, colored, translucent)
- Panel mounting
- Provides dual function (on/off) circuit switching and protection
- Current ratings (3 to 35 amps)

### PERFORMANCE CHARACTERISTICS

<b>Vibrations</b>	10G	
<b>Mechanical Shock</b>	50G	
<b>Acceleration</b>	10G	
<b>Weight</b>	39 grams	
<b>Interrupt Current</b>	2,000 amps at 30 VDC 1,000 amps at 120 VAC, 400 Hz	
<b>Endurance</b>	5,000 cycles: 120 VAC, 400 Hz inductive 5,000 cycles: 120 VAC, 400 Hz resistive 2,500 cycles: 28 VDC, 400 Hz inductive	2,500 cycles: 28 VDC, 400 Hz resistive 10,000 cycles: Mechanical, no load

### CALIBRATION CHART

For a Standard Device

Temp.	Minimum Ultimate Trip	Maximum Ultimate Trip	Trip Time (in seconds)
			200%
25°C	110%	150%	10–130
<i>The most typical device is 3–35 amps. For others, please contact us.</i>			



## DIMENSIONS

Dimensions in mm [Inch]

### Top View

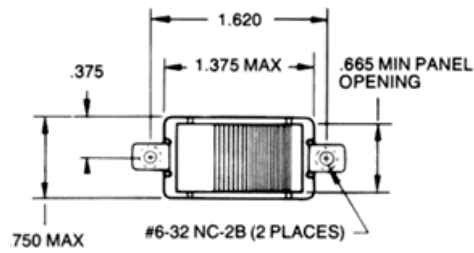

### Side View

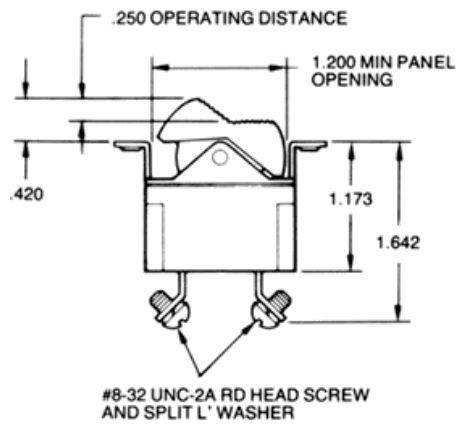



X	Options
1	Push On / Landing Light
2	Push On / Nav Light
3	Push On / Anti-Coll
4	Push On / Pitot Heat
5	Push On / Boost Pump
6	Push On / Glide Slope
7	Push On / Marker Beacon
8	Push On / Strobe Light
9	Off
10	Off
11	"SR to Invert Marking"
13	Push On / Rotating Beacon
16	Push On / Elevator Trim
18	Push On / Radio Master
19	Push On / LDG Light
20	On / Off
21	Off
22	"Colored Box"
23	Off
25	On / Off
26	Off /On
27	Push On / Low Boost
28	Push On / High Boost
29	Push On / WX Radar
30	Push On / Prop De-Ice
33	Push On / Standby Vac
34	No Actuator
35	On / Off

Sensata Technologies, Inc. ("Sensata") data sheets are solely intended to assist designers ("Buyers") who are developing systems that incorporate Sensata products (also referred to herein as "components"). Buyer understands and agrees that Buyer remains responsible for using its independent analysis, evaluation and judgment in designing Buyer's systems and products. Sensata data sheets have been created using standard laboratory conditions and engineering practices. Sensata has not conducted any testing other than that specifically described in the published documentation for a particular data sheet. Sensata may make corrections, enhancements, improvements and other changes to its data sheets or components without notice.

Buyers are authorized to use Sensata data sheets with the Sensata component(s) identified in each particular data sheet. HOWEVER, NO OTHER LICENSE, EXPRESS OR IMPLIED, BY ESTOPPEL OR OTHERWISE TO ANY OTHER SENSATA INTELLECTUAL PROPERTY RIGHT, AND NO LICENSE TO ANY THIRD PARTY TECHNOLOGY OR INTELLECTUAL PROPERTY RIGHT, IS GRANTED HEREIN. SENSATA DATA SHEETS ARE PROVIDED "AS IS". SENSATA MAKES NO WARRANTIES OR REPRESENTATIONS WITH REGARD TO THE DATA SHEETS OR USE OF THE DATA SHEETS, EXPRESS, IMPLIED OR STATUTORY, INCLUDING ACCURACY OR COMPLETENESS. SENSATA DISCLAIMS ANY WARRANTY OF TITLE AND ANY IMPLIED WARRANTIES OF MERCHANTABILITY, FITNESS FOR A PARTICULAR PURPOSE, QUIET ENJOYMENT, QUIET POSSESSION, AND NON-INFRINGEMENT OF ANY THIRD PARTY INTELLECTUAL PROPERTY RIGHTS WITH REGARD TO SENSATA DATA SHEETS OR USE THEREOF.

All products are sold subject to Sensata's terms and conditions of sale supplied at [www.sensata.com](http://www.sensata.com) SENSATA ASSUMES NO LIABILITY FOR APPLICATIONS ASSISTANCE OR THE DESIGN OF BUYERS' PRODUCTS. BUYER ACKNOWLEDGES AND AGREES THAT IT IS SOLELY RESPONSIBLE FOR COMPLIANCE WITH ALL LEGAL, REGULATORY AND SAFETY-RELATED REQUIREMENTS CONCERNING ITS PRODUCTS, AND ANY USE OF SENSATA COMPONENTS IN ITS APPLICATIONS, NOTWITHSTANDING ANY APPLICATIONS-RELATED INFORMATION OR SUPPORT THAT MAY BE PROVIDED BY SENSATA.

Mailing Address: Sensata Technologies, Inc., 529 Pleasant Street, Attleboro, MA 02703, USA.

## CONTACT US

### Americas

+1 (508)-236-3287  
klixon@sensata.com

### AUTHORIZED DISTRIBUTORS

Flame Enterprises  
Bob Correa, Director of Product Management  
+1 (240) 236-9802  
bcorrea@flamecorp.com  
info@flamecorp.com | Web  
Tel: 1-800-854-2255 or 1-818-700-2905  
Fax: 1-818-407-5080

Peerless Electronics  
Steve Gunther, National Sales Manager

+1 (516) 594-3509  
sgunther@peerlesselectronics.com  
nysales@peerlesselectronics.com | Web  
Tel: 1-800-285-2121  
Fax: 1-800-222-8096

### Europe, Middle East & Africa

Flame Enterprises  
Bob Correa, Director of Product Management  
+1 (240) 236-9802  
bcorrea@flamecorp.com  
info@flamecorp.com | Web  
Tel: 1-800-854-2255 or 1-818-700-2905  
Fax: 1-818-407-5080