



Sensata Technologies

4344 SERIES



Neumüller

Elektronik GmbH

Autorisierter Distributor:

Neumüller Elektronik GmbH | Gewerbegebiet Ost 7 | D-91085 Weisendorf
Tel. +49 9135 73666-0 | info@neumueller.com | www.neumueller.com



4344 SERIES

HERMETIC SEALED THERMOSTATS

Introduction

The Klixon® 4344 precision thermostat is constructed with a snap-acting bimetal disc, which serves as the actuating element. As the temperature reaches a pre-determined calibration point, the disc snaps to its reverse curvature producing a crisp, positive switching action inherent to Klixon® thermostats. This feature assures reliable, consistent operating temperature over a long cycle life. The standard thermostat is copper-nickel plated with silver contacts. Other plating finishes are available upon request. Gold plated contacts can be furnished for the electrical loads listed in the table below to assure reliable circuit switching under low wattage conditions. Gold plated contacts are not suitable for higher loads.

Our most common mounting configurations are depicted in the following pages. Many other varieties are available. Leads can be welded to pin type terminals to form an integral unit.

The switch can be custom packed into a probe, strap mount, or immersion thermostat. Consult the factory for special requests.

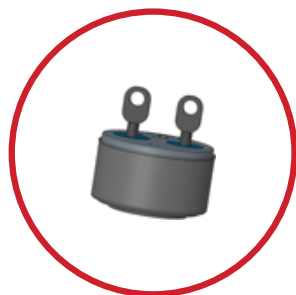

4344 - 7



4344 - 101



4344 - 142

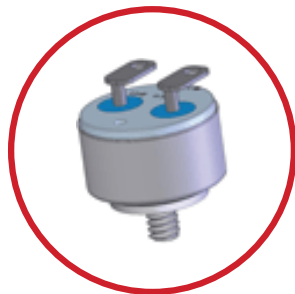

4344 - 135

Features

- Snap-action switching
- Rapid thermal response
- Single pole, single throw
- Normally open or normally closed
- Pre-set, non adjustable calibration

Applications

- Semiconductor cryogenic pumps
- Hazardous duty motors
- Submersible pumps
- Fire suppression equipment
- Medical X-ray tubes
- Medical incubator thermal control
- Locomotive and rail car heaters
- Marine engine heaters

Switching Action

All thermostats are supplied with single pole, single throw switching. The contacts can be constructed as:

Normally Closed: Limit type application; contacts open on temperature rise at a predetermined temperature to de-energize the circuit. Contacts automatically re-close as the device cools to a pre-determined temperature.

Normally Open: Fan type application; contacts close on temperature rise at a predetermined temperature to energize the circuit. Contacts automatically reopen as the device cools to a predetermined temperature.

The opening and closing temperatures are pre-set and non-adjustable.

Typical Cross Section View

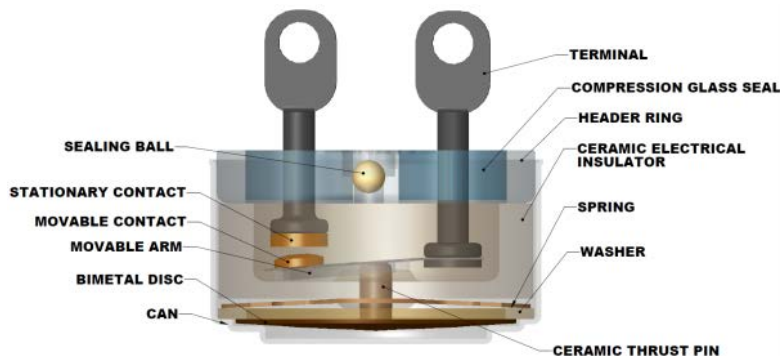

Operation

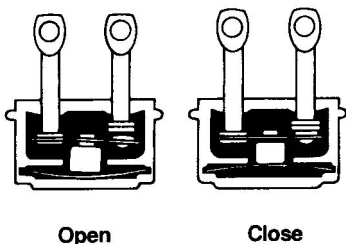

When heated, the internal stresses of the bi-metal cause the disc to reverse its curvature with a snap-action at a fixed, preset temperature and operate the electrical contacts.

A decrease in the ambient temperature below the reset temperature of the disc relieves the internal stresses in the disc. The disc returns to its normal curvature and the contacts assume their normal operating position.

SPECIFICATIONS

Performance Characteristics

Switch Action	SPST (Snap Action)																															
Contact Resistance	0.050 ohms maximum per MIL-STD-202, Method 307																															
Contact Ratings	<table border="1"> <thead> <tr> <th>30 VAC/DC</th> <th>125 VAC</th> <th>250 VAC</th> <th rowspan="2">Life Cycles</th> </tr> <tr> <th colspan="3">Amperes</th> </tr> </thead> <tbody> <tr> <td>5.0</td> <td>2.5</td> <td>1.0</td> <td>100,000</td> </tr> <tr> <td>5.5</td> <td>3.0</td> <td>1.5</td> <td>50,000</td> </tr> <tr> <td>6.0</td> <td>4.0</td> <td>2.0</td> <td>25,000</td> </tr> <tr> <td>6.5</td> <td>5.0</td> <td>2.5</td> <td>10,000</td> </tr> <tr> <td>7.0</td> <td>6.0</td> <td>3.0</td> <td>5,000</td> </tr> </tbody> </table>			30 VAC/DC	125 VAC	250 VAC	Life Cycles	Amperes			5.0	2.5	1.0	100,000	5.5	3.0	1.5	50,000	6.0	4.0	2.0	25,000	6.5	5.0	2.5	10,000	7.0	6.0	3.0	5,000		
	30 VAC/DC	125 VAC	250 VAC	Life Cycles																												
	Amperes																															
	5.0	2.5	1.0	100,000																												
	5.5	3.0	1.5	50,000																												
6.0	4.0	2.0	25,000																													
6.5	5.0	2.5	10,000																													
7.0	6.0	3.0	5,000																													
	Based on standard differential																															
Dielectric Strength	1250 VAC, rms, 60 Cycles for 1 minute, terminal to case, per MIL-STD-202, Method 301																															
Vibration Resistance	5-2000 Hm, 20G, per MIL-STD-202, Method 204 Condition D, (unmonitored)																															
Shock Resistance	100G, 6 milliseconds, per MIL-STD-202, Method 213																															
Hermeticity	1 x 10 ⁻⁵ atm cc/sec. max per MIL-STD-202 Method 112, Condition C																															
Salt Spray	per MIL-STD-202, Method 101, Condition B, 5% solution																															
Weight	Basic Unit	4.8 grams																														
	with Bracket	5.8 grams																														

Gold Contact Ratings (Resistive)

30 VAC/DC	500 mA and below
115 VAC	200 mA and below
230 VAC	100 mA and below

Temperature

Ambient Temperature Range	-80°F to +550°F (-62.2°C to 287.8°C)																		
Operating Temperature	Temperature at which normally closed contacts open or normally open contacts closed.																		
Tolerance	Allowable range above and below setpoint and reset temperatures * An additional $\pm 3^{\circ}\text{F}$ tolerance is required for over molded devices.																		
Differential	Operating Temperature						Differential						Tolerance*						
	°F		°C		°F		°C		°F		°C		°F		°C				
	-65	-53.9	30	16.7	10	5.6	210	98.9	30	16.7	8	4.4	220	104.4	30	16.7	8	4.4	
	-40	-40.0	30	16.7	10	5.6	230	110.0	30	16.7	8	4.4	240	115.6	30	16.7	8	4.4	
	-15	-26.1	30	16.7	10	5.6	250	121.1	30	16.7	8	4.4	260	126.7	30	16.7	8	4.4	
	0	-17.8	20	11.1	5	2.8	270	132.2	30	16.7	8	4.4	280	137.8	30	16.7	8	4.4	
	10	-12.2	20	11.1	5	2.8	290	143.3	30	16.7	8	4.4	300	148.9	30	16.7	8	4.4	
	20	-6.7	20	11.1	5	2.8	310	154.4	40	22.2	12	6.7	320	160.0	40	22.2	12	6.7	
	30	-1.1	20	11.1	5	2.8	330	165.6	40	22.2	12	6.7	340	171.1	40	22.2	12	6.7	
	40	4.4	20	11.1	5	2.8	350	176.7	40	22.2	12	6.7	375	190.6	40	22.2	12	6.7	
	50	10.0	20	11.1	5	2.8	400	204.4	40	22.2	12	6.7	425	218.3	40	22.2	12	6.7	
	60	15.6	20	11.1	5	2.8	450	232.2	40	22.2	12	6.7	475	246.1	70	38.9	25	13.9	
	70	21.1	20	11.1	5	2.8	500	260.0	70	38.9	25	13.9	525	273.9	70	38.9	25	13.9	
	80	26.7	20	11.1	5	2.8	550	287.8	70	38.9	25	13.9							
	90	32.2	20	11.1	5	2.8													
	100	37.8	20	11.1	5	2.8													
	110	43.3	20	11.1	5	2.8													
	120	48.9	20	11.1	5	2.8													
	130	54.4	20	11.1	5	2.8													
	140	60.0	20	11.1	5	2.8													
	150	65.6	20	11.1	5	2.8													
160	71.1	20	11.1	5	2.8														
170	76.7	20	11.1	5	2.8														
180	82.2	20	11.1	5	2.8														
190	87.8	20	11.1	5	2.8														
200	93.9	20	11.1	5	2.8														
Materials and Finish	Unplated 304 stainless for all new designs. (other finishes available upon request)																		

Standard Lead Connections

Leads are available in heat-resistant rubber, neoprene, silicone-rubber and Teflon* in #118 gauge stranded wire in standard incremental lengths of 4" to 36". Other gauge and lengths are available upon request.

* Trademark of E.I. DuPont de Nemours and Co.



DIMENSION

An additional $\pm 3^\circ\text{F}$ tolerance is required for over molded devices.
All dimensions are in inches

4344 - 7

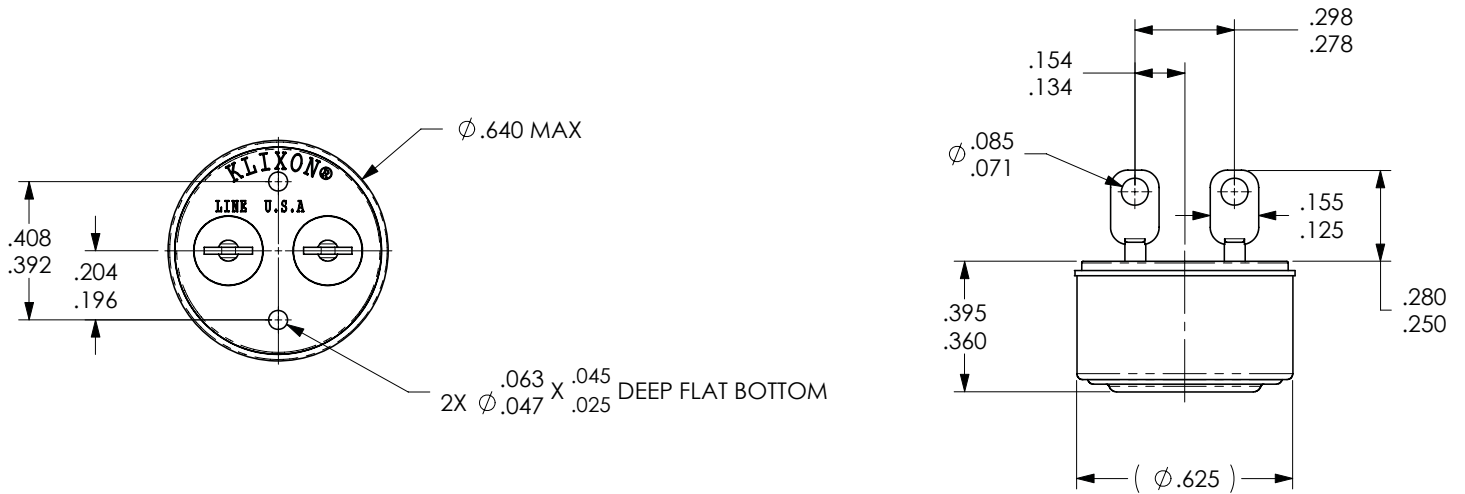

4344 - 32

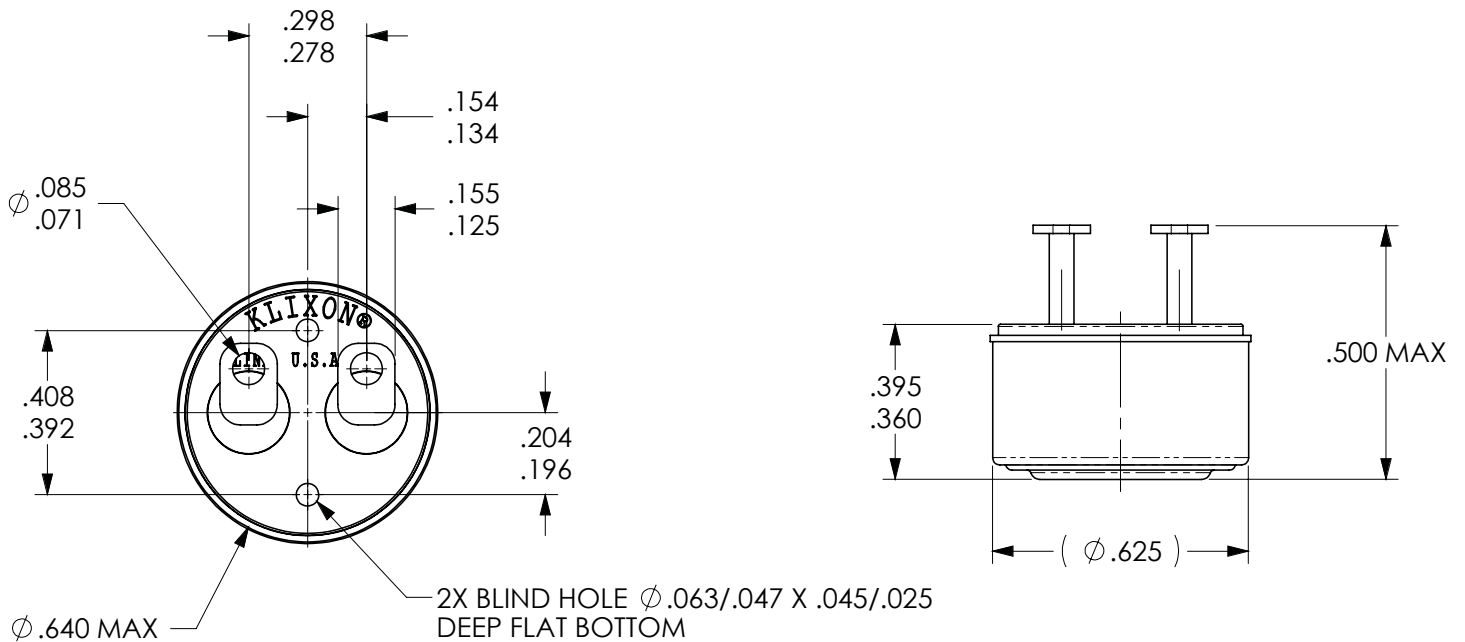

4344 - 184

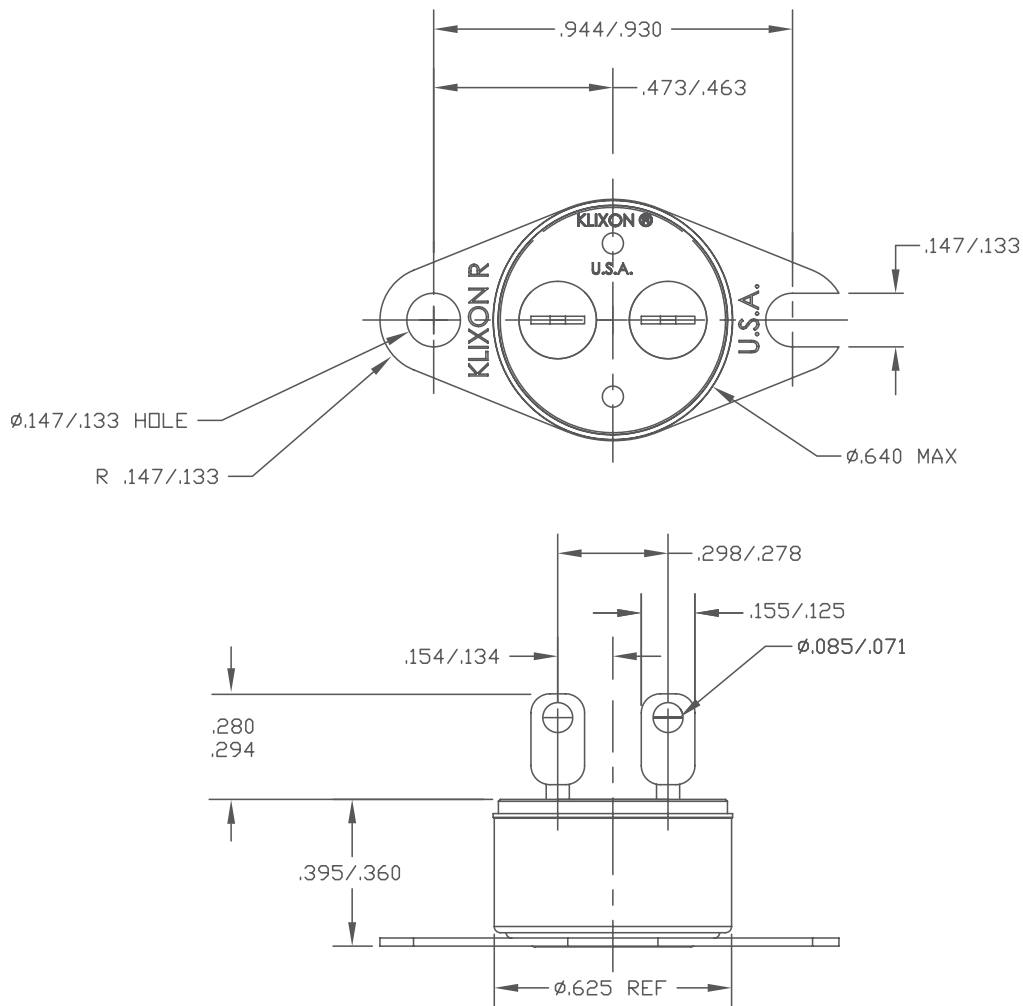

4344 - 144

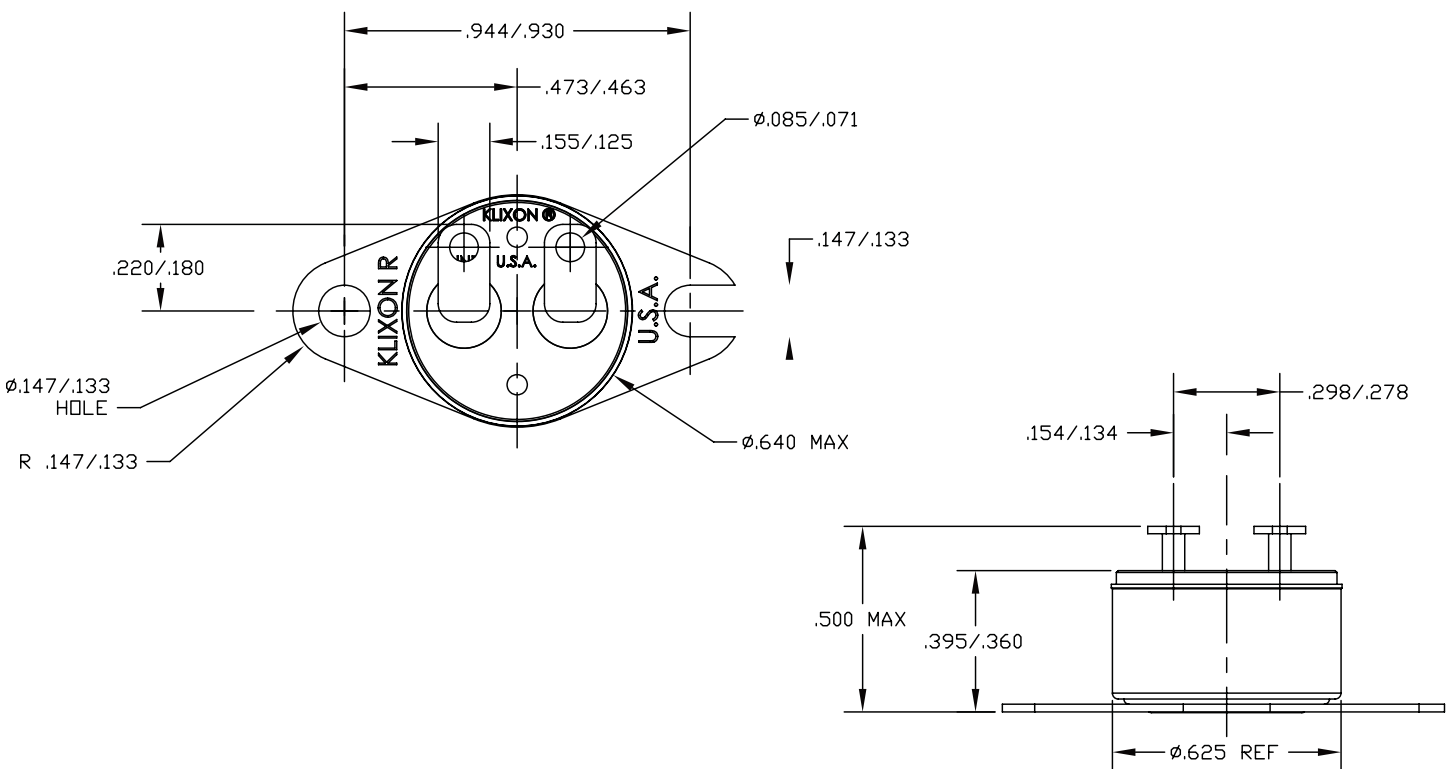

4344 - 145

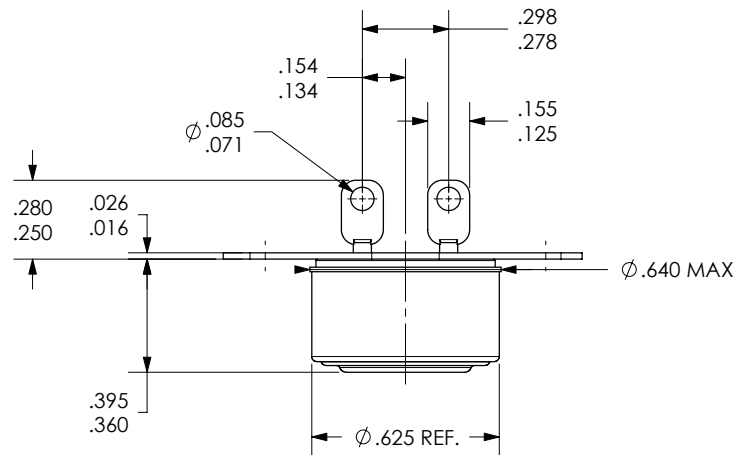
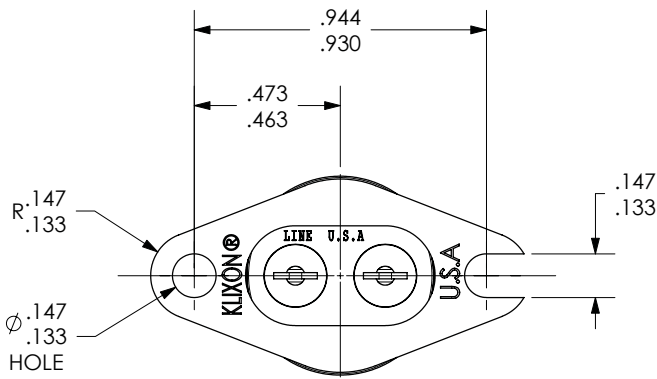

4344 - 13

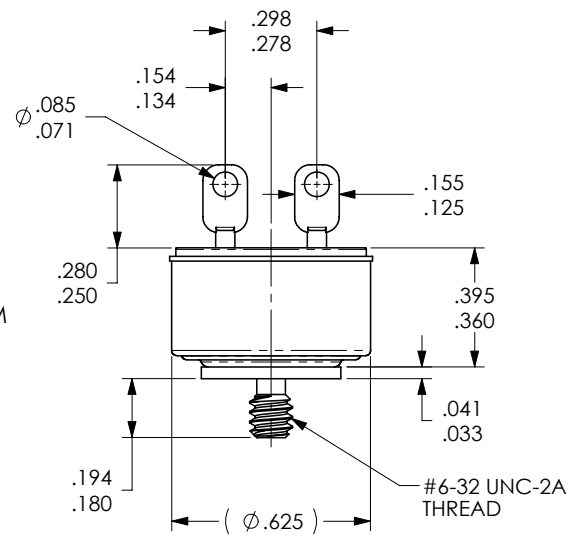
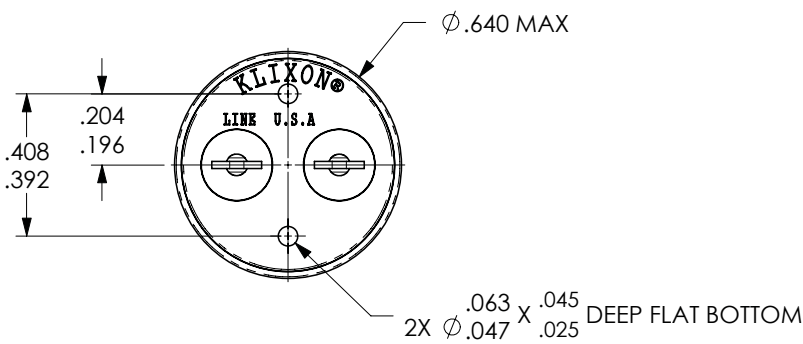

4344 - 106

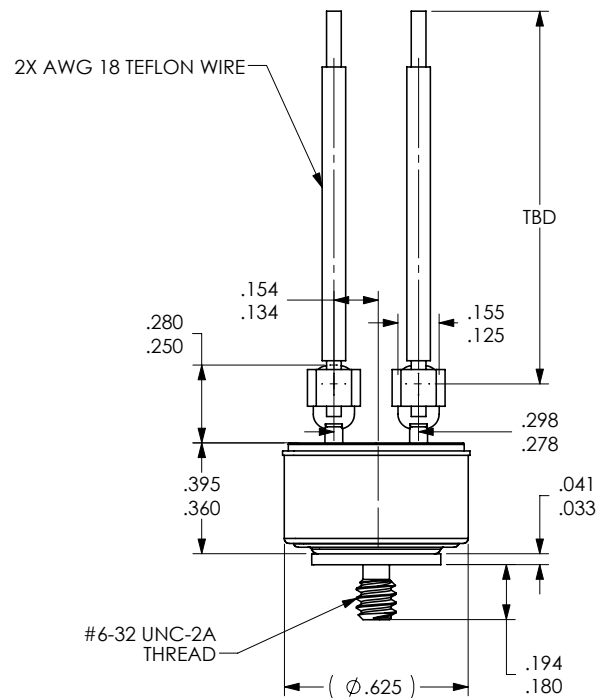
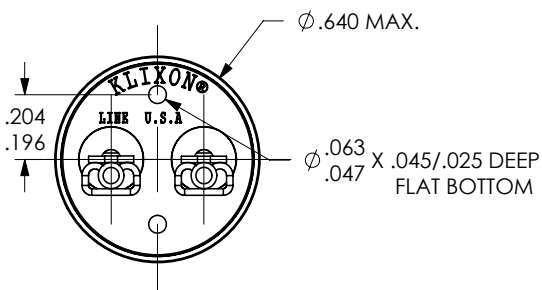

4344 - 357 - 1

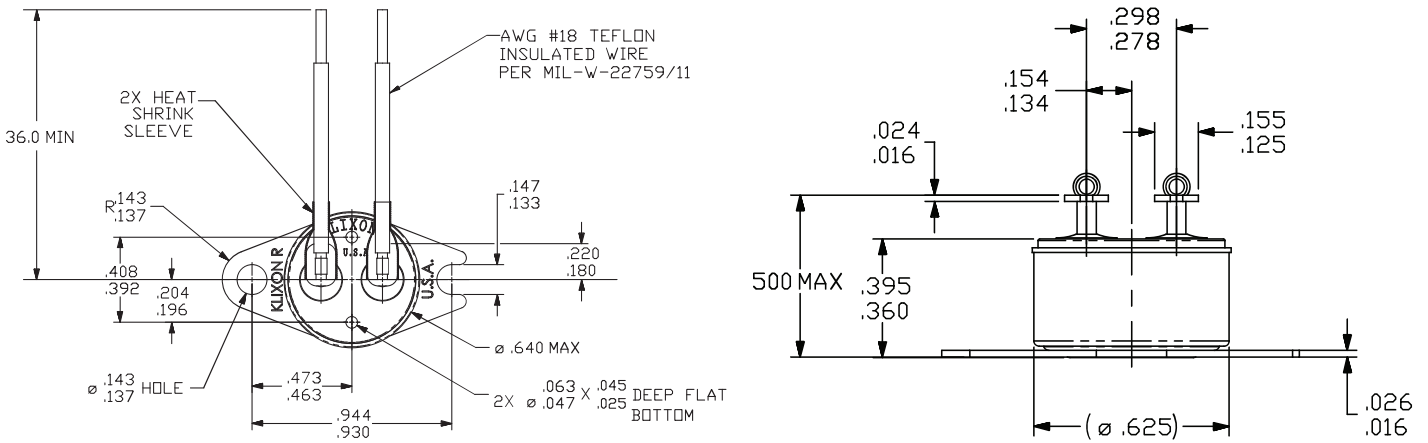

AGENCY APPROVALS AND CERTIFICATIONS



UL	File No. 34618
CSA	File No. LR24458

WARNINGS



RISK OF MATERIAL DAMAGE AND HOT ENCLOSURE

- The product's side panels may be hot, allow the product to cool before touching
- Follow proper mounting instructions including torque values
- Do not allow liquids or foreign objects to enter this product

Failure to follow these instructions can result in serious injury, or equipment damage.



HAZARD OF ELECTRIC SHOCK, EXPLOSION OR ARC FLASH

- Disconnect all power before installing or working with this equipment
- Verify all connections and replace all covers before turning on power

Failure to follow these instructions will result in death or serious injury

Sensata Technologies, Inc. ("Sensata") data sheets are solely intended to assist designers ("Buyers") who are developing systems that incorporate Sensata products (also referred to herein as "components"). Buyer understands and agrees that Buyer remains responsible for using its independent analysis, evaluation and judgment in designing Buyer's systems and products. Sensata data sheets have been created using standard laboratory conditions and engineering practices. Sensata has not conducted any testing other than that specifically described in the published documentation for a particular data sheet. Sensata may make corrections, enhancements, improvements and other changes to its data sheets or components without notice.

Buyers are authorized to use Sensata data sheets with the Sensata component(s) identified in each particular data sheet. HOWEVER, NO OTHER LICENSE, EXPRESS OR IMPLIED, BY ESTOPPEL OR OTHERWISE TO ANY OTHER SENSATA INTELLECTUAL PROPERTY RIGHT, AND NO LICENSE TO ANY THIRD PARTY TECHNOLOGY OR INTELLECTUAL PROPERTY RIGHT, IS GRANTED HEREIN. SENSATA DATA SHEETS ARE PROVIDED "AS IS". SENSATA MAKES NO WARRANTIES OR REPRESENTATIONS WITH REGARD TO THE DATA SHEETS OR USE OF THE DATA SHEETS, EXPRESS, IMPLIED OR STATUTORY, INCLUDING ACCURACY OR COMPLETENESS. SENSATA DISCLAIMS ANY WARRANTY OF TITLE AND ANY IMPLIED WARRANTIES OF MERCHANTABILITY, FITNESS FOR A PARTICULAR PURPOSE, QUIET ENJOYMENT, QUIET POSSESSION, AND NON-INFRINGEMENT OF ANY THIRD PARTY INTELLECTUAL PROPERTY RIGHTS WITH REGARD TO SENSATA DATA SHEETS OR USE THEREOF.

All products are sold subject to Sensata's terms and conditions of sale supplied at www.sensata.com SENSATA ASSUMES NO LIABILITY FOR APPLICATIONS ASSISTANCE OR THE DESIGN OF BUYERS' PRODUCTS. BUYER ACKNOWLEDGES AND AGREES THAT IT IS SOLELY RESPONSIBLE FOR COMPLIANCE WITH ALL LEGAL, REGULATORY AND SAFETY-RELATED REQUIREMENTS CONCERNING ITS PRODUCTS, AND ANY USE OF SENSATA COMPONENTS IN ITS APPLICATIONS, NOTWITHSTANDING ANY APPLICATIONS-RELATED INFORMATION OR SUPPORT THAT MAY BE PROVIDED BY SENSATA.

Mailing Address: Sensata Technologies, Inc., 529 Pleasant Street, Attleboro, MA 02703, USA.

CONTACT US

Americas
 +1 (508)-236-3287
klixon@sensata.com
 Ask for Aerospace