



Sensata

Technologies

6752-100 SERIES



Autorisierter Distributor:

Neumüller Elektronik GmbH | Gewerbegebiet Ost 7 | D-91085 Weisendorf
Tel. +49 9135 73666-0 | info@neumueller.com | www.neumueller.com



| 6752-100 SERIES

50–100 Amp, Single–Phase, 3–Phase, Ambient Compensated

Introduction

Klixon® 6752-100 series thermal–magnetic circuit breakers are designed and manufactured to meet stringent military standards with the reliability of the 6752 design. The 6752-100 is similar to the 6752-12 in size, and includes current ratings ranging from 50 to 100 amps.

The higher interrupting capacity, vibration resistance and longer cycling life of the 6752-100 series exceed previous military standards. In addition, the 6752-100 series provide ambient compensation, fault coordination of all ratings an option for auxiliary circuits.



Features

- Current ratings: 50–100 amps
- Proven reliability and performance of the 6752 series circuit breaker
- Trip–free design
- Circuit protection unaffected by temperature fluctuations
- MIL-C-5809 qualified
- Ambient compensated
- High vibration resistance
- High interrupting capacity: 6,000 amps
- Typical use: Military



PERFORMANCE CHARACTERISTICS

Vibrations	10G, 50–2,000 Hz (other vibration levels available)
Mechanical Shock	30G
Acceleration	10G
Weight	113.6 gram (0.25 pound) maximum
Interrupt Current	120VAC, 400 Hz: 3,500 amps 28 VDC: 6,000 amps
Endurance	5,000 cycles: 120 VAC, 400 Hz inductive 5,000 cycles: 120 VAC, 400 Hz resistive 2,500 cycles: 28 VDC, 400 Hz inductive 5,000 cycles: 28 VDC, 400 Hz resistive 5,000 cycles: Mechanical, no load



QUALIFICATIONS

Klixon®	Mil-spec
6752-100-50	MS25361-50
6752-102-50	MS25361-50
6752-100-60	MS25361-60
6752-102-60	MS25361-60
6752-100-70	MS25361-70
6752-102-70	MS25361-70
6752-100-75	MS25361-75
6752-102-75	MS25361-75
6752-100-80	MS25361-80
6752-102-80	MS25361-80
6752-100-90	MS25361-90
6752-102-90	MS25361-90
6752-100-100	MS25361-100
6752-102-100	MS25361-100



CALIBRATION CHART

For a Standard Device

Temp.	Minimum Ultimate Trip	Maximum Ultimate Trip	Trip Time (in seconds)		
			200%	500%	1000%
25°C	105%	138%	15-65	2-10	1-4
-40°C	125%	165%	15-65	2-10	1-4
70°C	70%	125%	15-65	2-10	1-4

The most typical device is 3–35 amps. For others, please contact us.



DIMENSIONS

Dimensions in mm [Inch]

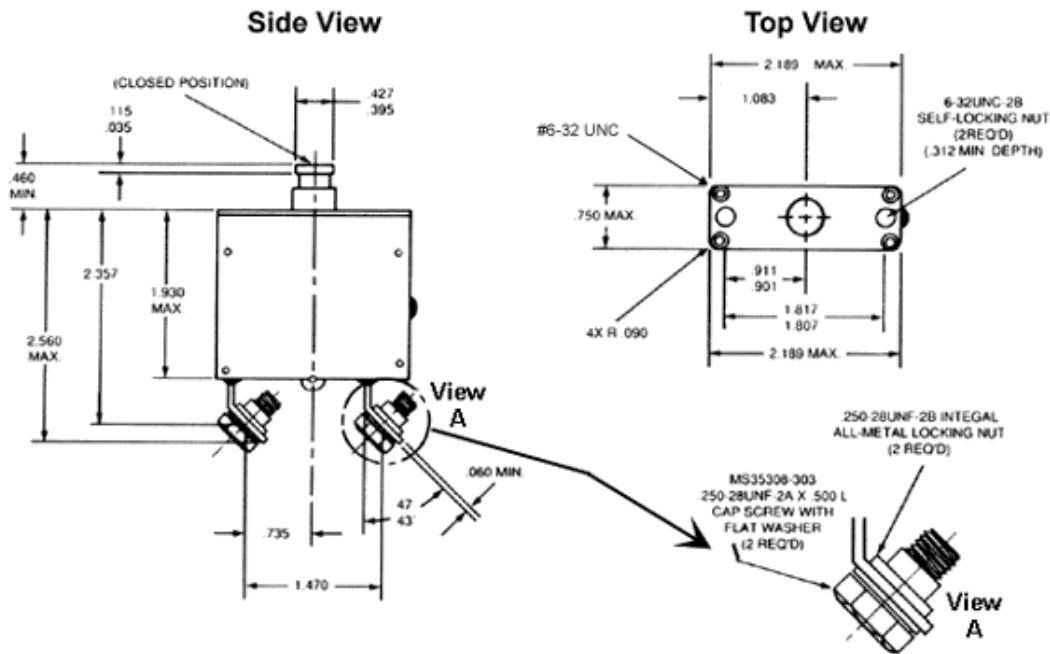

Sensata Technologies, Inc. ("Sensata") data sheets are solely intended to assist designers ("Buyers") who are developing systems that incorporate Sensata products (also referred to herein as "components"). Buyer understands and agrees that Buyer remains responsible for using its independent analysis, evaluation and judgment in designing Buyer's systems and products. Sensata data sheets have been created using standard laboratory conditions and engineering practices. Sensata has not conducted any testing other than that specifically described in the published documentation for a particular data sheet. Sensata may make corrections, enhancements, improvements and other changes to its data sheets or components without notice.

Buyers are authorized to use Sensata data sheets with the Sensata component(s) identified in each particular data sheet. HOWEVER, NO OTHER LICENSE, EXPRESS OR IMPLIED, BY ESTOPPEL OR OTHERWISE TO ANY OTHER SENSATA INTELLECTUAL PROPERTY RIGHT, AND NO LICENSE TO ANY THIRD PARTY TECHNOLOGY OR INTELLECTUAL PROPERTY RIGHT, IS GRANTED HEREIN. SENSATA DATA SHEETS ARE PROVIDED "AS IS". SENSATA MAKES NO WARRANTIES OR REPRESENTATIONS WITH REGARD TO THE DATA SHEETS OR USE OF THE DATA SHEETS, EXPRESS, IMPLIED OR STATUTORY, INCLUDING ACCURACY OR COMPLETENESS. SENSATA DISCLAIMS ANY WARRANTY OF TITLE AND ANY IMPLIED WARRANTIES OF MERCHANTABILITY, FITNESS FOR A PARTICULAR PURPOSE, QUIET ENJOYMENT, QUIET POSSESSION, AND NON-INFRINGEMENT OF ANY THIRD PARTY INTELLECTUAL PROPERTY RIGHTS WITH REGARD TO SENSATA DATA SHEETS OR USE THEREOF.

All products are sold subject to Sensata's terms and conditions of sale supplied at www.sensata.com. SENSATA ASSUMES NO LIABILITY FOR APPLICATIONS ASSISTANCE OR THE DESIGN OF BUYERS' PRODUCTS. BUYER ACKNOWLEDGES AND AGREES THAT IT IS SOLELY RESPONSIBLE FOR COMPLIANCE WITH ALL LEGAL, REGULATORY AND SAFETY-RELATED REQUIREMENTS CONCERNING ITS PRODUCTS, AND ANY USE OF SENSATA COMPONENTS IN ITS APPLICATIONS, NOTWITHSTANDING ANY APPLICATIONS-RELATED INFORMATION OR SUPPORT THAT MAY BE PROVIDED BY SENSATA.

Mailing Address: Sensata Technologies, Inc., 529 Pleasant Street, Attleboro, MA 02703, USA.

CONTACT US

Americas

+1 (508) 236-3287
klixon@sensata.com

AUTHORIZED DISTRIBUTORS

Flame Enterprises
Bob Correa, Director of Product Management
+1 (240) 236-9802
bcorrea@flamecorp.com
info@flamecorp.com | Web
Tel: 1-800-854-2255 or 1-818-700-2905
Fax: 1-818-407-5080

Peerless Electronics
Steve Gunther, National Sales Manager

+1 (516) 594-3509
sgunther@peerlesselectronics.com
nysales@peerlesselectronics.com | Web
Tel: 1-800-285-2121
Fax: 1-800-222-8096

Europe, Middle East & Africa

Flame Enterprises
Bob Correa, Director of Product Management
+1 (240) 236-9802
bcorrea@flamecorp.com
info@flamecorp.com | Web
Tel: 1-800-854-2255 or 1-818-700-2905
Fax: 1-818-407-5080