



Sensata

Technologies

C SERIES

CA, CM, CDA, CDM



Neumüller

Elektronik GmbH

Autorisierter Distributor:

Neumüller Elektronik GmbH | Gewerbegebiet Ost 7 | D-91085 Weisendorf
Tel. +49 9135 73666-0 | info@neumueller.com | www.neumueller.com



| C SERIES (CA, CM, CDA, CDM)

2 TO 40 AMP COMMERCIAL THERMAL CIRCUIT BREAKER

Introduction

The C series thermal breakers are designed to protect wiring and meet the harshest environmental requirements. The C series closed construction circuit breakers are weatherproof sealed for protection against moisture, dust, grease, fuel vapors and other harsh environments. The C series breakers are compact, lightweight and designed to interrupt short circuits or overloads, and combine trip-free protection with fast response time. Typical applications are protection of wire cable of accessory circuits, equipment and battery protection in construction and off-road equipment, marine, recreational vehicles (RV's), mining, agricultural equipment and electric (hybrid) vehicles.



Features

- 30VDC or 120VAC, 2 to 40 Amps
- Open and closed construction
- Automatic and manual reset options
- Ignition protected SAE J1171
- Weatherproof SAE J553
- UL Recognized E36869

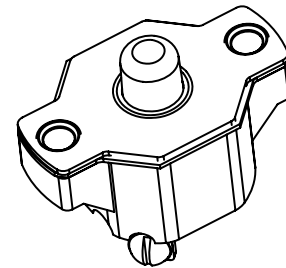

SPECIFICATIONS

Calibration : 200% rated current, 77°F (25°C)	2 to 10 amps : 20 to 150 seconds 12.5 to 40 amps : 5 to 55 seconds
Ultimate Trip At 77°F (25°C)	Must hold 100%, Must trip 135%
Endurance	Per SAE J553
Interrupt Current Capacity	Per SAE J553 and ABYC E-11
Vibration	10G MIL-STD-202 Method 204, Condition A
Mechanical Shock	MIL-STD-202 Method 101D (sealed only)
Dielectric Strength	MIL-STD-202 Method 301, 1500VAC min
Insulation Resistance	MIL-STD-202 Method 302, Condition B, 100MΩ min
Weight	CDM: 48 grams max CDA: 41 grams max CM : 37 grams max CA : 32 grams max



TRIP CURVE

Approximate Time, Current Characteristics At 77°F (25°C)

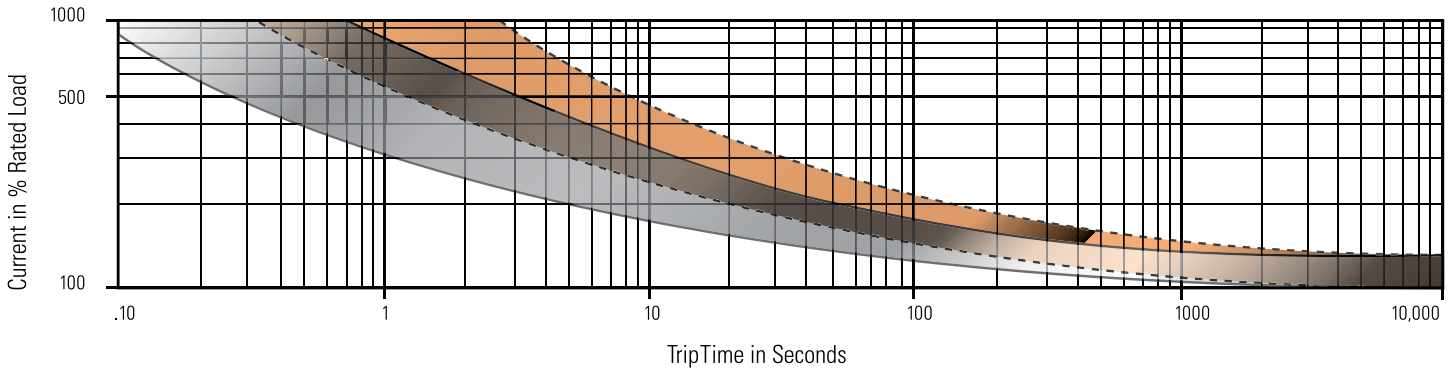

Dotted Lines: 10 amps or below
 Solid Lines: Above 10 amps



DIMENSIONS

All dimensions are in inches [mm]

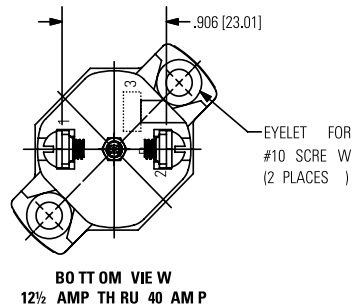
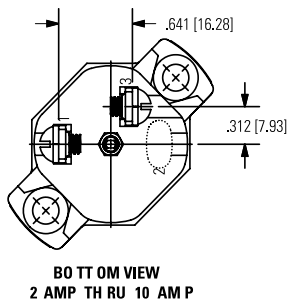
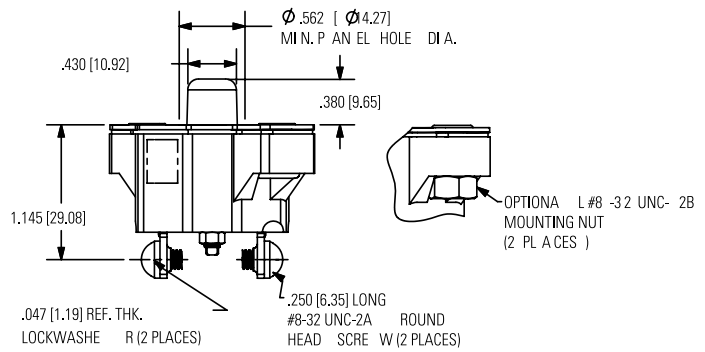
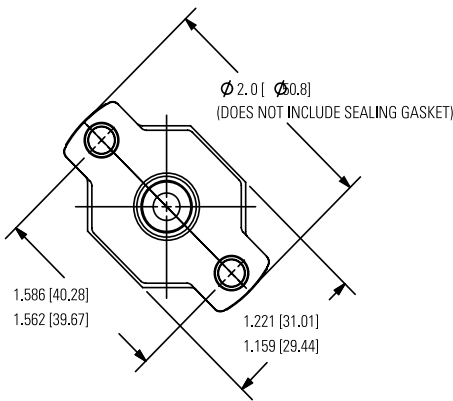



DERATING CURVE

Performance characteristics are based on room temperature (77°F, 25°C). Consult derating curve for ambient temperatures significantly higher or lower than standard room temperature. Example: At 77°F (25°C) the device is calibrated to hold at 100% of rated current (1) and trip at 135% of rated current (2). At 140°F (60°C), the same device will hold at approximately 78% of rated current (3), and trip at approximately 115% of rated current (4).

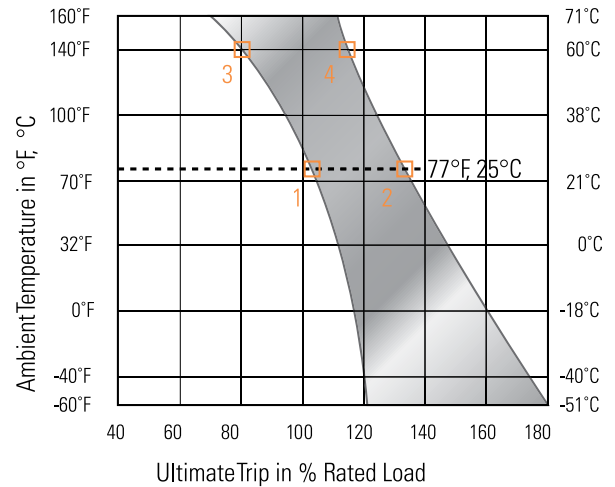

ORDERING OPTIONS

Example : CA-15-

Configuration

CA

15

- CA: Auto, open unit
- CM: Manual, open unit
- CDA: Auto, sealed unit
- CDM: Manual, sealed unit

Amp Rating

2	6	15	30
3	8	17.5	35
4	10	20	40
5	12.5	25	

Mounting Nuts

- : Leave blank for none
- I: Optional mounting nuts

CONTACT US**AUTHORIZED DISTRIBUTORS****Americas**

Flame Enterprises
 Contact Name:
 Bob Correa, Director of Product Management
 Direct Phone: +1 (240) 236-9802
 E-mail: bcorrea@flamecorp.com
 info@flamecorp.com | Web
 Tel: 1-800-854-2255 or 1-818-700-2905
 Fax: 1-818-407-5080

Peerless Electronics
 Contact Name:
 Steve Gunther, National Sales Manager
 Direct Phone: +1 (516) 594-3509
 E-mail: sgunther@peerlesselectronics.com
 nysales@peerlesselectronics.com | Web
 Tel: 1-800-285-2121
 Fax: 1-800-222-8096

Europe, Middle East & Africa

Flame Enterprises
 Contact Name:
 Bob Correa, Director of Product Management
 Direct Phone: +1 (240) 236-9802
 E-mail: bcorrea@flamecorp.com
 info@flamecorp.com | Web
 Tel: 1-800-854-2255 or 1-818-700-2905
 Fax: 1-818-407-5080

AUTHORIZED SALES REPRESENTATIVES

Country	Representative	Contact	E-mail	Phone
Brazil	Sonnensys Technologies	Maury Sampaio	maury.sampaio@sonnensys.com	+55 12 99768 1100
Austria	Telemeter	Robert Jall	rjall@telemeter.de	49 906 70693-26
Belgium	JB Controls	Jean Jacques Boher	jboher@jbcontrols.com	33 (0)1 46 91 93 30
Czech Republic	Telemeter	Robert Jall	rjall@telemeter.de	49 906 70693-26
Denmark	Sensor Control Nordic	Peter BJÖRKDAHL	peter.bjorkdahl@scn.se	46 (0)8 122 006 92
Estonia	Sensor Control Nordic	Peter BJÖRKDAHL	peter.bjorkdahl@scn.se	46 (0)8 122 006 92
Finland	Sensor Control Nordic	Peter BJÖRKDAHL	peter.bjorkdahl@scn.se	46 (0)8 122 006 92
France	JB Controls	Jean Jacques Boher	jboher@jbcontrols.com	33 (0)1 46 91 93 30
Germany	Telemeter	Robert Jall	rjall@telemeter.de	49 906 70693-26
Greece	PanSystem	Stefano Vitone	stefano.vitone@pansystem.com	39 335 7169958
Israel	Admati	Dori Shifman	dori@admati.com	972 (0)50 331 4700
Italy	PanSystem	Stefano Vitone	stefano.vitone@pansystem.com	39 335 7169958
Latvia	Sensor Control Nordic	Peter BJÖRKDAHL	peter.bjorkdahl@scn.se	46 (0)8 122 006 92
Lithuania	Sensor Control Nordic	Peter BJÖRKDAHL	peter.bjorkdahl@scn.se	46 (0)8 122 006 92
Luxembourg	JB Controls	Jean Jacques Boher	jboher@jbcontrols.com	33 (0)1 46 91 93 30
Netherlands	TBD			
Norway	Sensor Control Nordic	Peter BJÖRKDAHL	peter.bjorkdahl@scn.se	46 (0)8 122 006 92
Poland	Radiotechnika	Tomasz Póltoraczyk	tpoltoraczyk@radiotechnika.com.pl	48 7132 70 765
Portugal	PanSystem	Stefano Vitone	stefano.vitone@pansystem.com	39 335 7169958
Slovakia	Telemeter	Robert Jall	rjall@telemeter.de	49 906 70693-26
Spain	PanSystem	Stefano Vitone	stefano.vitone@pansystem.com	39 335 7169958
Sweden	Sensor Control Nordic	Peter BJÖRKDAHL	peter.bjorkdahl@scn.se	46 (0)8 122 006 92
Switzerland	JB Controls	Jean Jacques Boher	jboher@jbcontrols.com	33 (0)1 46 91 93 30
Turkey	Eltronik	Ergun Kosem	ergun@eltronik.com	90 312 440 7815
UK	Charcroft	Julie Protheroe	julie.protheroe@charcroft.com	01591 612240
Australia	AeroDefense	Trent Ralph	trent@aerodefence.com.au	+61 7 5503 0552
China	Pomic Ltd.	James Cai	James.cai@pomicltd.com	+1 (360) 915-7806
China (ACCBs only)	Shanghai Jin Feng Electronics & Inst Co	Wang Min-Gang	yonghuqian@vip.sina.com	+86-21-62712648
India	Hical Technologies	VB Venkatesh	venkatesh.vb@hical.com	+91 98450-12341
Indonesia	Precision Technologies	Aaron Lim	aaronlim@pretech.com.sg	+65 (62) 73 45 73 x125
Japan	Intertek Industries	Masa Ikeda	masai@intertekindustries.com	+1 (310) 309-9661
Korea	Aero Sensors Corp.	Jonathan Jo	jangcho@aerosensors.co.kr	+82 2 557 5355
Malaysia	Precision Technologies	Aaron Lim	aaronlim@pretech.com.sg	+65 (62) 73 45 73 x125
New Zealand	AeroDefense	Trent Ralph	trent@aerodefence.com.au	+61 7 5503 0552
Singapore	Precision Technologies	Aaron Lim	aaronlim@pretech.com.sg	+65 (62) 73 45 73 x125
Taiwan	Sensata Technologies	Bob Jacques	bjacques@sensata.com	+1 (805) 716-0586

Sensata Technologies, Inc. ("Sensata") data sheets are solely intended to assist designers ("Buyers") who are developing systems that incorporate Sensata products (also referred to herein as "components"). Buyer understands and agrees that Buyer remains responsible for using its independent analysis, evaluation and judgment in designing Buyer's systems and products. Sensata data sheets have been created using standard laboratory conditions and engineering practices. Sensata has not conducted any testing other than that specifically described in the published documentation for a particular data sheet. Sensata may make corrections, enhancements, improvements and other changes to its data sheets or components without notice.

Buyers are authorized to use Sensata data sheets with the Sensata component(s) identified in each particular data sheet. HOWEVER, NO OTHER LICENSE, EXPRESS OR IMPLIED, BY ESTOPPEL OR OTHERWISE TO ANY OTHER SENSATA INTELLECTUAL PROPERTY RIGHT, AND

NO LICENSE TO ANY THIRD PARTY TECHNOLOGY OR INTELLECTUAL PROPERTY RIGHT, IS GRANTED HEREIN. SENSATA DATA SHEETS ARE PROVIDED "AS IS". SENSATA MAKES NO WARRANTIES OR REPRESENTATIONS WITH REGARD TO THE DATA SHEETS OR USE OF THE DATA SHEETS, EXPRESS, IMPLIED OR STATUTORY, INCLUDING ACCURACY OR COMPLETENESS. SENSATA DISCLAIMS ANY WARRANTY OF TITLE AND ANY IMPLIED WARRANTIES OF MERCHANTABILITY, FITNESS FOR A PARTICULAR PURPOSE, QUIET ENJOYMENT, QUIET POSSESSION, AND NON-INFRINGEMENT OF ANY THIRD PARTY INTELLECTUAL PROPERTY RIGHTS WITH REGARD TO SENSATA DATA SHEETS OR USE THEREOF.

All products are sold subject to Sensata's terms and conditions of sale supplied at www.sensata.com SENSATA ASSUMES NO LIABILITY FOR APPLICATIONS ASSISTANCE OR THE DESIGN OF BUYERS' PRODUCTS. BUYER ACKNOWLEDGES AND AGREES THAT IT IS SOLELY RESPONSIBLE FOR COMPLIANCE WITH ALL LEGAL, REGULATORY AND SAFETY-RELATED REQUIREMENTS CONCERNING ITS PRODUCTS, AND ANY USE OF SENSATA COMPONENTS IN ITS APPLICATIONS, NOTWITHSTANDING ANY APPLICATIONS-RELATED INFORMATION OR SUPPORT THAT MAY BE PROVIDED BY SENSATA.

Mailing Address: Sensata Technologies, Inc., 529 Pleasant Street, Attleboro, MA 02703, USA.