



CONTENTS

What's in a name?	5
How our business is organized	6

HEATING, VENTILATION & AIRCONDITIONING

3HM	8
15HM	10
16HM	12
31/32/33HM	14
34HM	16
35HM	18
37HM	20
7895	22
7HT, 8HT, 9HT & 14HT	24

MAJOR HOME APPLIANCES

4TM	26
MSC	30
PHENOLIC	34

SMALL APPLIANCES INDUSTRIAL & LIGHTING

1NT	40
3NT	46
20413, 20600 and 20650 Series	50
20425 Series	56
20490, 20491, 20492 and 20493 Series	60
204 Series	62

2AM/3AM/4AM/8AM	64
2MM	68
3MP	70
3MPSH	72
4CR	74
7AM	76
15AM	78
17AM	80
9700	82
MA10	84
RP	86
SB/ESB Series	90
TH10	92
TH11, TH21	94
YS10	96
YS11	98

AUTOMOTIVE ELECTRICAL PROTECTION

MAXI	102
SMB	104
5AP	106
6AP	108
Mini 100	110

GENERAL ST THERMOSTAT PORTFOLIO ...	112
-------------------------------------	-----

Sensata Business Overview

A QUICK LOOK AT SENSATA AND ITS ORGANIZATION



WHAT'S IN A NAME?

Sensata Technologies is a world leader and early innovator in mission-critical sensors and electrical protection. The name Sensata comes from the Latin word *sensata*, meaning “those gifted with sense”.

We are all about deep understanding, impressive collaboration, practical creativity, and unwavering integrity, and have been for over 95 years.

On average, Sensata manufactures over 16,000 different products and ships over 1 billion units a year under the familiar brand names Klixon®, Airpax®, Dimensions™, Qinex™ and Sensor-NITE. Our devices are used in automotive, appliance, aircraft, industrial, military, heavy vehicle, heating, air conditioning, data, telecommunications, recreational vehicle and marine applications.

Sensata devices help satisfy the world’s growing need for safety, energy efficiency and a clean environment. We believe that improving the safety, efficiency and comfort of millions of people every day makes sense - for Sensata, our employees, our customers and the world.



THE SENSATA FAMILY OF BRANDS



•• HOW OUR BUSINESS IS ORGANIZED

Overall, we have two main global business units (Controls and Sensors) and worldwide global operations supported by business and product development centers and sales offices.

Sensing Solutions

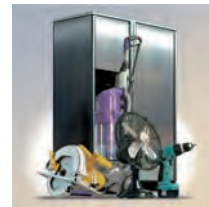

Our Sensing Solutions is a major player in worldwide electrical and power protection industries.

For more about our electrical protectors, see sensata.com

Our products monitor pressure and temperature and prevent damage from overheating and fires, protecting people from injury. Sensing Solutions offers the newest in protection devices, such as breakthrough low-power combo starter-protectors, as well as some extremely long-lived products such as the 70-year-old ¾-inch Klixon motor protector, a standard around the world.

Most households use at least 30 Sensata products

So, where might you find us?

Commercial jets are typically equipped with 500 to 1,500 Sensata circuit breakers and switches

IN YOUR HOME – The typical household has well over 30 of our products in places like refrigerators, washers and dryers, garbage disposals, recessed lighting, power tools and batteries, exhaust fans and air conditioning units.

AT WORK – Our devices protect fluorescent lights from overheating and keep industrial conveyor belts operating safely, while keeping work environments comfortable.

IN YOUR CAR – We're used in windshield wiper motors, seat adjustments, engine cooling systems, diesel fuel heaters, sun roof motors, window lifts and air pumps.

AT PLAY – Boats and recreational vehicles rely on our switches to keep them operating safely and efficiently.

IN THE SKY – Between 500 and 1,500 of our circuit breakers and switches are found on every commercial jet. We're also in military vehicles, ships and satellites.

HEATING & INDUSTRIAL – In the HVAC and industrial markets our sensors and switches offer protection from high-pressure and low-pressure cutout in air conditioning systems. These controls are used in gas furnaces, heat pumps and appliances. Pressure transducers made by the Sensing Solutions help regulate refrigeration systems, industrial pumps, forklifts and fuel cells.

Sensing Solutions designs and manufactures:

- Controls
- Protectors
- Thermostats
- Circuit breakers
- Switches
- Test devices
- Battery disconnects

for...

- Appliances
- Heating, ventilation and A/C
- Industrial and lighting
- Cars, boats, work trucks, RVs
- Aircraft
- Defense, security, traffic controls
- Electronic and back-up power

Performance Sensing



Performance Sensing business is a market leader in automotive, heating, ventilation, air conditioning and industrial markets. Our products include a full line of pressure sensors for cars, trucks and heavy off-road vehicles – and they do everything from improving safety and performance to helping the environment by reducing emissions. Sensors and switches made by this business detect pressure, temperature, air flow, gas, humidity, speed, position and provide on/off controls used in automotive, industrial and HVAC applications.

AUTOMOTIVE – Sensata has been the world leader in automotive pressure sensing since 2002. In vehicles, our components are found in air conditioning systems, power steering systems, engines, fuel emission and braking and suspension systems. A pressure switch manifold made by this business senses hydraulic pressure in automatic transmissions while our occupant classification sensors help keep air bags operating safely so they can do the job they’re meant to do.

More recently, we’ve begun moving into other areas such as speed and position sensing. We have introduced solar and twilight sensors, and now have a new line of high temperature sensors used in diesel after-treatment exhaust systems.

To read more about our sensors, please visit sensata.com

Our automotive sensors include:

- Acceleration sensors
- Transmission range sensors
- Occupant classification sensors
- Cylinder pressure sensors
- Turbo pressure sensors
- Magnetic speed and position sensors
- High temperature sensors

Worldwide Locations

Belgium: Olen

Brazil: Campinas

Bulgaria: Botevgrad, Sofia

China: Baoying, Changzhou, Shanghai

Dominican Republic: Haina

Japan: Oyama, Saitama, Tokyo

Korea: Jincheon, Seoul

Malaysia: Subang Jaya, Selangor

Mexico: Aguascalientes

Netherlands: Almelo

USA: Arizona, Maryland, Massachusetts, Minnesota

Worldwide: Sales offices

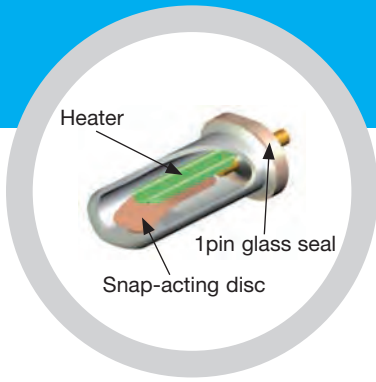

KLIXON | 3HM Series

Hermetically sealed motor protector for single-phase on-winding protection

PRODUCT OVERVIEW

- High reliability – 2 contact ratings
- Compact oval construction for smaller device profile
- Meet rotary compressor high side pressure requirements
- Application range – 1 to 2 ½HP

The 3HM hermetic overload protectors are new generation product designed to meet the demands of tomorrow's compressors. The 3HM family of motor protectors can be applied to air conditioning compressors ranging from 1 to 2½ HP. They may also be used in commercial motors which must function in high-pressure corrosive environments. Its low profile allows ease of installation, while the overall design provides resistance to mechanical shock.

Line Break Operation

Klixon 3HM motor protectors are line break automatic reset controls which are wired in series with the motor windings. These protectors are designed to track winding temperatures and respond to changes in line current, which provides protection against the

overload conditions listed below;

- Running overload
- High/low voltage locked rotor
- High voltage light load
- High discharge temperature

Constructions

The basic element in the hermetic motor protector series is the Klixon snap-acting disc. An integral series heater allows close control of ON times, and longer cycle rates when stalled rotor condition exists. Glass sealed header is resistant welded to the steel case to provide a hermetic seal. Optional wire leads, sleeve and terminal connector can be provided.

Dimensions Metric Dimensions in Parentheses.

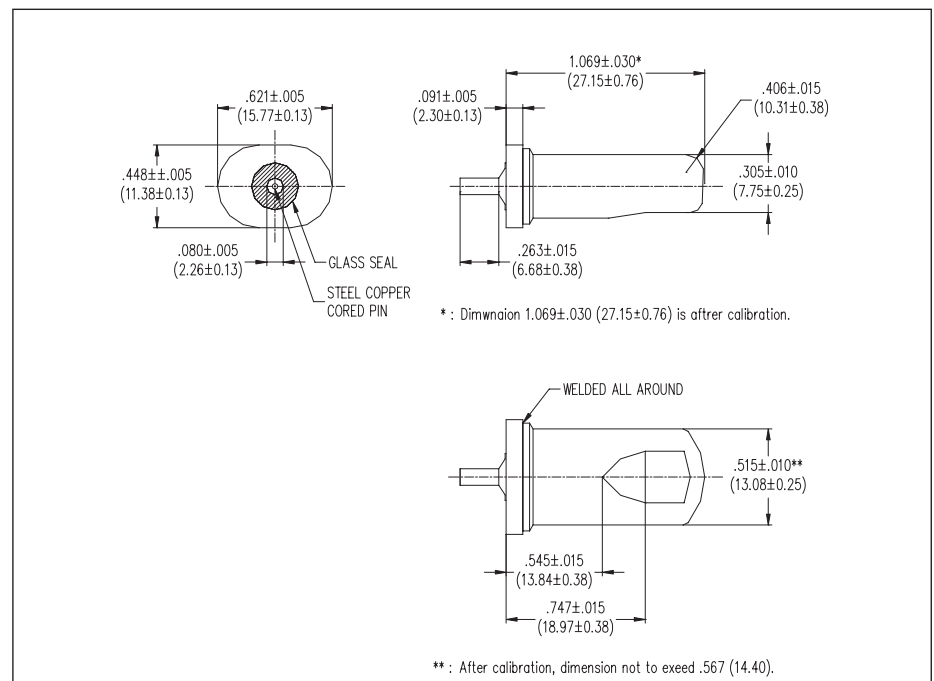

HEATING, VENTILATION & AIRCONDITIONING

Protector Ratings

Series	Line Locked Voltage	Rotor Current
1XX 2XX 3XX 4XX	230	*60 Amp
5XX 6XX	230	*80 Amp

*To be used as a guide for selection only, consult factory for specific life test data.

Certifications

Certification	Standards	Certification#
UL	UL2111	E15962
ENEC	EN60730-2-4	2018218.04

Rated capacity to be used as a guide for selection only, expert will consult for specific life test data.

Unique Type Reference

The coding system is defined as follows and particular numbers are assigned to each specific customer requests.

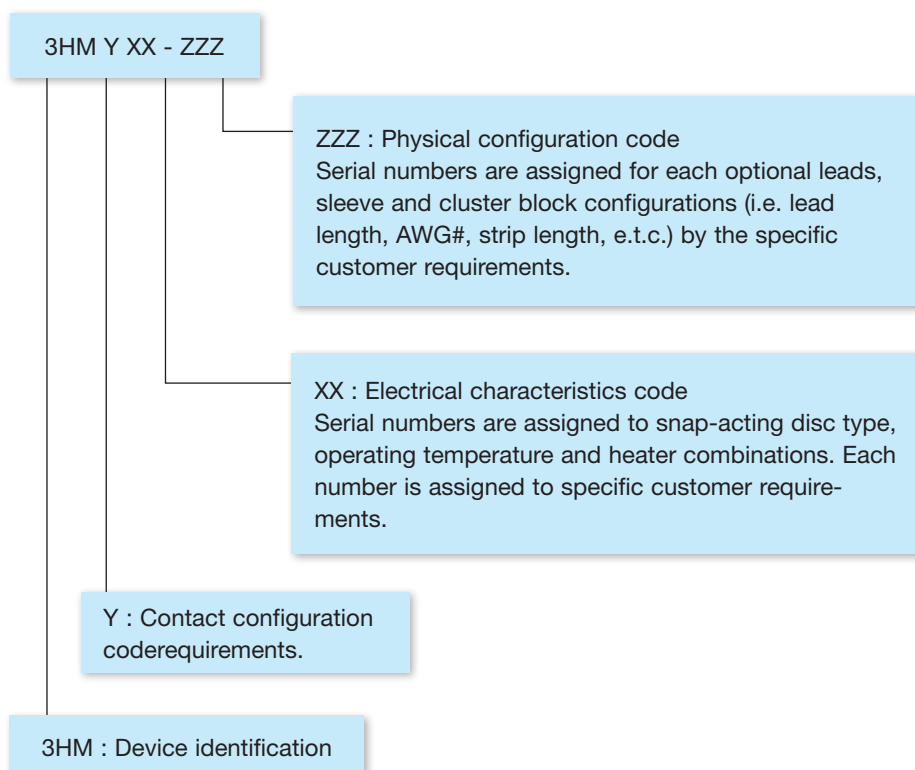

Technical Characteristics

Purpose of control: Thermal protector for motor compressor

Rated voltage: 240Vac

Rated current: 16A inductive load, 80A at p/f 0.6

Temperature Range: 90°C to 175°C

Ambient temp limits: Tmin=0°C / Tmax=200°C

Tolerance on Temp: Open +/- 5K
Close +/- 11K

Type of disconnection: Type3C

Pollution Situation: Normal

PTI for Insulation: PTI600

Enclosure protection degree: IP00

Example: 3HM525-36

- Bimetal of 35ohms/cm²
- Operating temperature 170°C
- Reset temperature 92°C with #6 heater
- High capacity contacts (80A)
- DMD-wire leads AWG#14
- 240mm (Can side) length and 190mm (Pin side) length with strip length 10mm
- Insulation sleeve by Toray Lummmror
- X10S, 55mm length





KLIXON® | 15HM SERIES MOTOR PROTECTORS

*Hermetically Sealed Single Phase
On Winding Protection*

PRODUCT OVERVIEW

The Klixon® 15HM Series hermetically sealed single phase on-winding motor protectors are a new generation product designed to meet the demands of tomorrow's compressors.

Features & Benefits

- High Reliability – 2 contact ratings
- Optional start winding protection
- Compact and rugged construction
- Meet rotary compressor high side pressure requirements
- Application range – 1 to 5 HP

Product Description

The 15HM family of motor protectors can be applied to unitary air conditioning and heat pump compressors ranging from 1 to 5 HP. They may also be used in commercial motors which must function in destructive or corrosive environments. Its compact and rugged design make it resistant to mechanical shock and suitable for installation directly on motor windings.

Line Break Operation

Klixon® 15HM motor protectors are line break automatic reset controls which are wired in series with and mounted on the motor windings. These protectors track winding temperatures and respond to changes in line current to afford protection against the wide variety of overload conditions listed below:

- Running overload
- High/low voltage locked rotor
- Loss of refrigerant charge
- Shorted capacitor
- High discharge temperature

15HM Code System

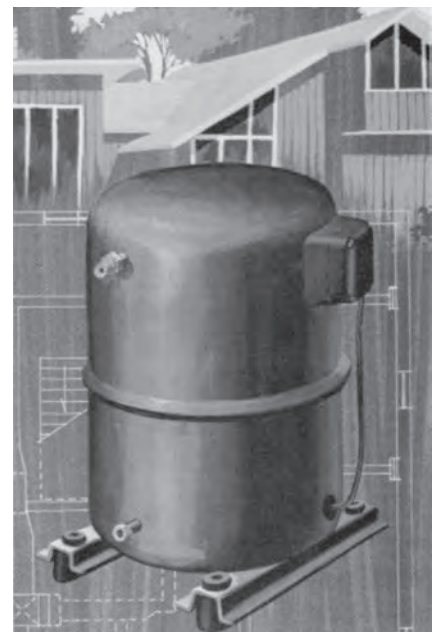
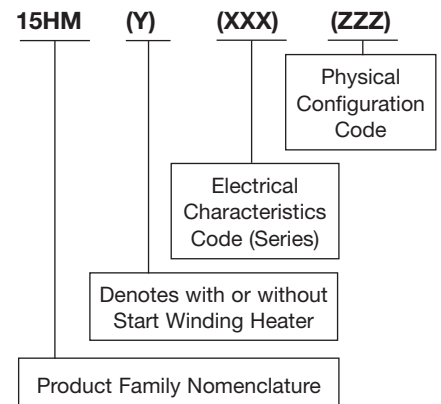

HEATING, VENTILATION & AIRCONDITIONING

Protector Ratings

Series	Product Family	Start Winding	Line Voltage	Locked Rotor Current	HP Range
300	13XX	Yes	230V	*100 Amp	*1 - 3 1/2
	23XX	No			
600	16XX	Yes	230V	*140 Amp	*3 1/2 - 5
	26XX	No			

*To be used as a guide for selection only, consult factory for specific life test data.

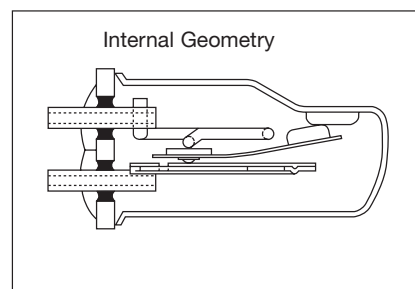

Dimensions (Metric Dimensions in Parenthesis)

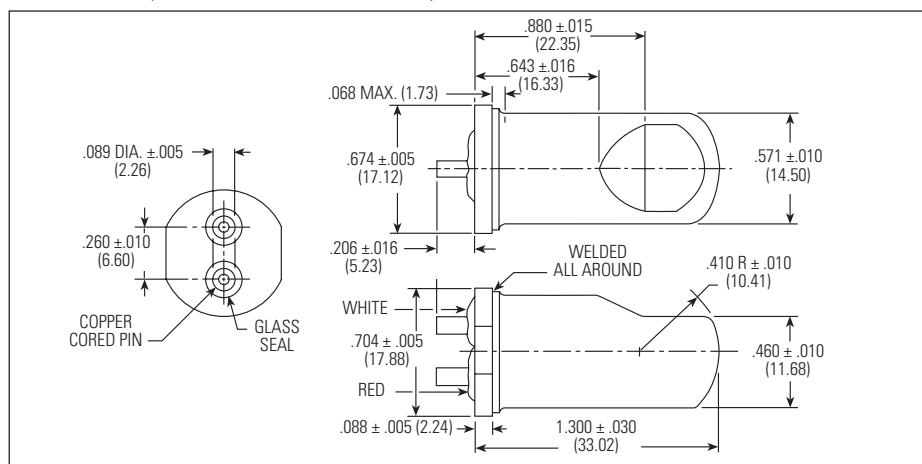

Specifications

Open Temperature 90°C - 150°C
 in 5°C increments
 Tolerance ±5°C Open
 ±9°C Close

Epoxy protected glass seals
 Optional terminations
 U/L Recognized-File E15962, Sec 42
 CSA Certified-File LR11372, Sec LLL

VDE approval with factory surveillance
 15HMXXX-XX
 16(16MAX100) ~~~~~
 250
 Overheat protection, T200

Circuit Diagram

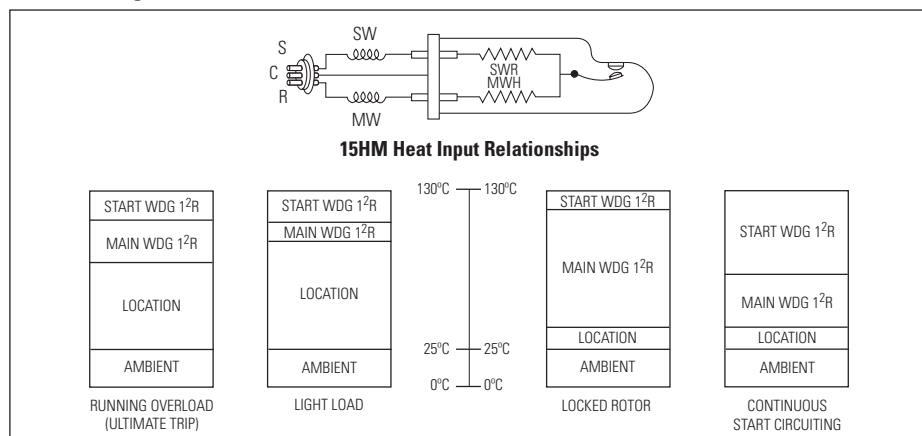



KLIXON® | 16HM SERIES MOTOR PROTECTORS

*Hermetically Sealed Single Phase
On Winding Protection*

PRODUCT OVERVIEW

The Klixon® 16HM series hermetically sealed single phase on-winding motor protectors are a new generation product designed to meet the demands of tomorrow's compressors. The 16HM family of motor protectors can be applied to air conditioning compressors ranging from 2 to 6HP*.

Features & Benefits

- Direct line break
- Automatic reset
- Compact and rugged construction
- Provides start winding protection
- Meets scroll and high side compressor requirements
- Application range - 2HP to 6HP*
- Tamperproof protection
- Hermetically sealed

Product Description

The 16HM utilizes two internal heaters. One of them is sensitive to start winding current and the other is sensitive to main winding current. The device can protect against start winding overheating and against conditions which generate high main winding currents. Its compact and rugged design make it resistant to mechanical shock and suitable for installation directly on motor windings.

Line Break Operation

Klixon® 16HM motor protectors are line break automatic reset controls which are wired in series with the motor windings.

These protectors are designed to track winding temperatures and to respond to changes in line current.

When properly applied, the 16HM can provide protection against motor overheating under the following conditions:

- Running overload
- High/low voltage locked rotor
- High voltage light load
- Loss of refrigerant charge
- Welded start relay
- Shorted capacitor
- Blocked condenser fan

16HM Code System

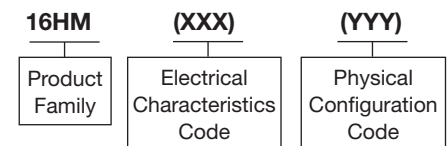

Basic 16HM Envelope

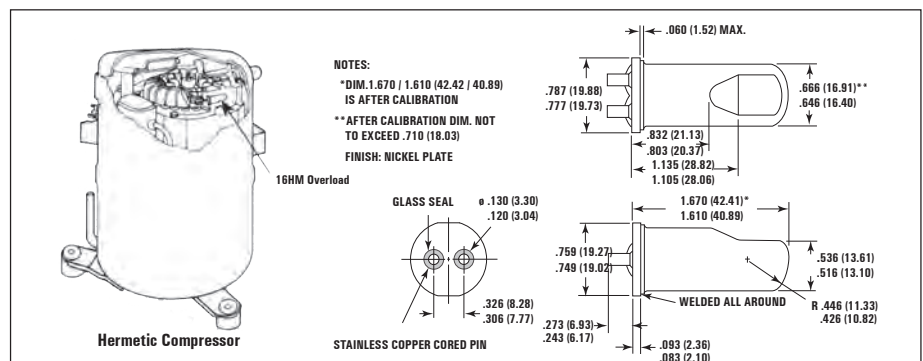

HEATING, VENTILATION & AIRCONDITIONING

16HM Termination Styles

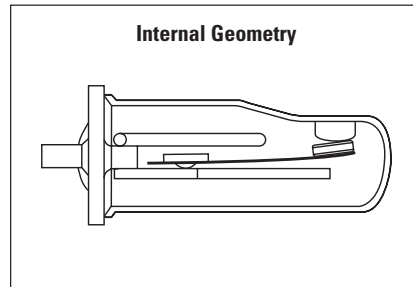
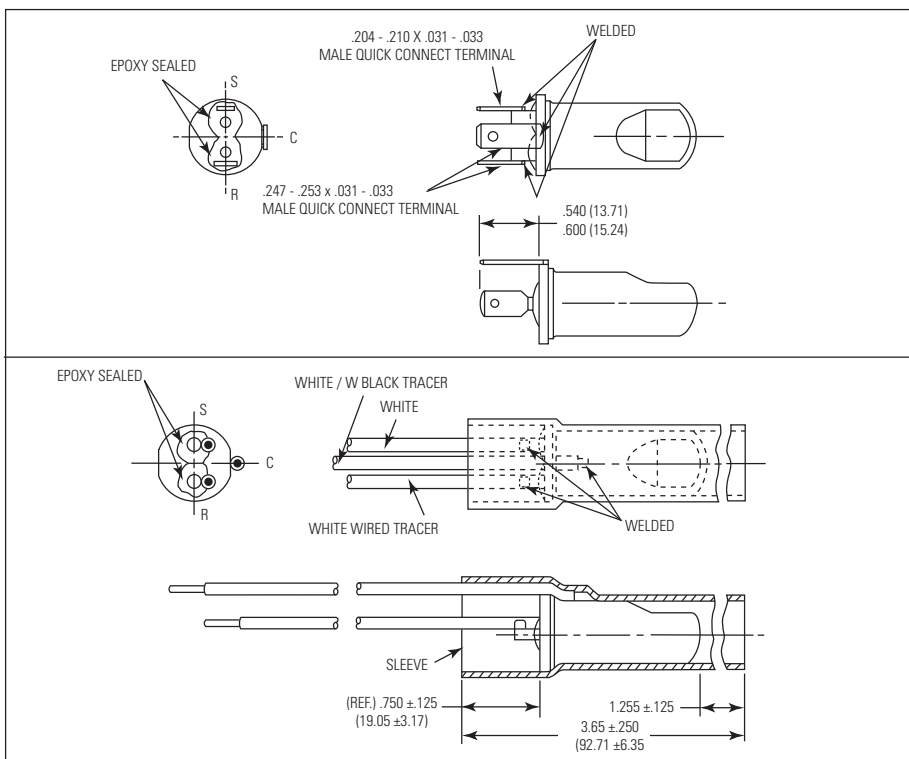

Protector Rating

Series	Line Voltage	Lock Rotor Current
16HM 1XX	230V	*165 Amps

*To be used as a guide for selection only, consult factory for specific life test data.

Specifications

Open Temperature 95°C - 155°C
in 5°C increments
Tolerance ±5°C Open
±9°C Close

Several termination options
U/L Recognized-File E15962
CSA Certified-File LR11372

Circuit Diagram

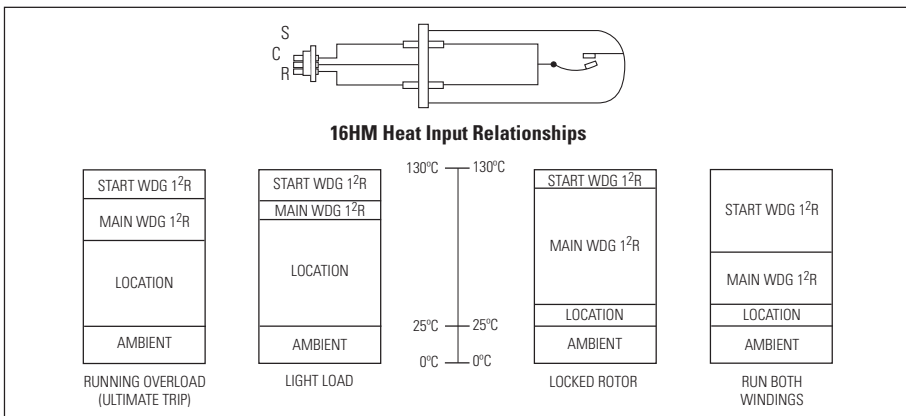



KLIXON® | 31, 32, 33HM SERIES MOTOR PROTECTORS

Hermetically Sealed On-Winding, 3-Phase

PRODUCT OVERVIEW

The Klixon® 31HM, 32HM, and 33HM on-winding motor protectors are 3-phase line break, automatic reset devices wired in series with each phase at the neutral point.

Features & Benefits

- Protect WYE (Star) wound 3-phase motors from 1 to 15HP. Used in refrigeration compressors, submersible pumps and other restrictive environments.
- Increased protection in a small size, with a rugged all welded construction. Low profile shape allows for close coupling to motor windings.
- Hermetic reliability designed for leakage rates less than 1×10^{-9} per second of air with 1 atmosphere pressure differential.
- Klixon® snap-action discs assure positive make and break action and controlled temperature differential.

excessive winding temperatures; however, applications may be made to any 3-phase motors where an environmental seal is required. Small size permits the devices to be installed directly on the motor windings for precise temperature monitoring, thus affording protection against such severe overload conditions as loss of refrigerant charge, low voltage locked rotor, and single phasing.

The 31HM, 32HM, and 33HM are designed to reduce installation costs by replacing pilot control systems with a simple, economical, compact device.

These protectors are designed to protect 3-phase refrigeration and air conditioning compressor motors from

Locked Rotor Current Capacity

	Std. 1XX Series			4XX Series	5XX Series			15XX HC Series		
	230V	460V	575V	230V	240V	460V	575V	230V	460V	575V
31HM	70A	40A	35A	60A	90A	50A	40A	Not Available		
32HM	135A	70A	55A	180A	200A	100A	80A	275A	175A	125A
33HM	Not Available			250A	285A	145A	115A	380A	190A	N/A

Current ratings are based on life test data which has demonstrated high reliability at 2000 cycles at 0.7 power factor on Sensata life test boards. These capacities are intended as a guide for application work.

31HM Series Hermetic Motor Protector

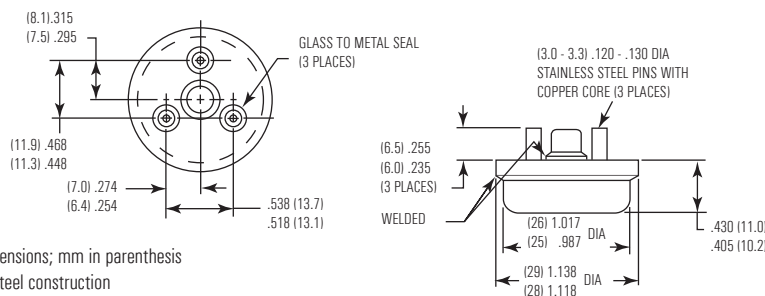

Metric Dimensions; mm in parenthesis
All plated steel construction

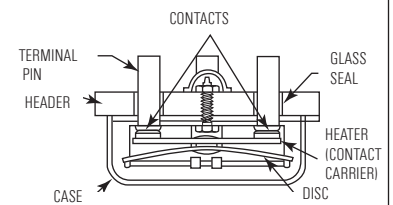

The basic element of the 31, 32, and 33HM is the famous Klixon® snap-acting disc.

Standard Operating Temperature
Opening Temperature
90°C to 170°C in 5°C increments
Tolerance ±5°C

Closing Temperature
to suit application
Tolerance
±9°C for <150°C opening
±15°C for ≥150°C

UL & Canadian-UL File # E15692
CQC File # CQC05002011992
KEMA (ENEC) File # 2018218.08

32HM Series Hermetic Motor Protector

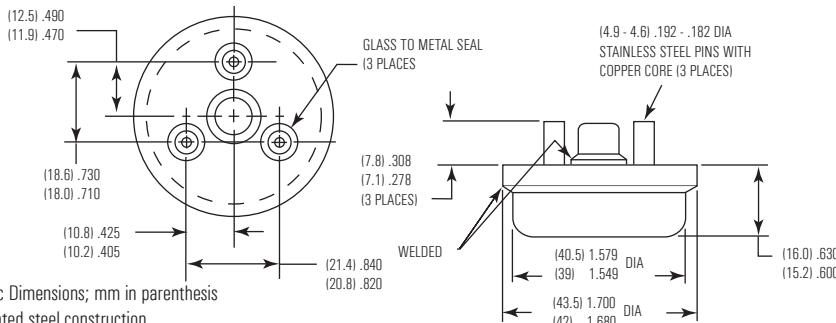

Metric Dimensions; mm in parenthesis
All plated steel construction

33HM Series Hermetic Motor Protector

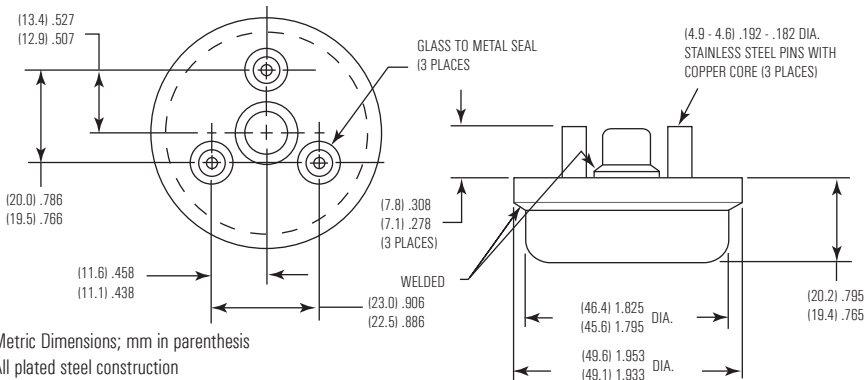

Metric Dimensions; mm in parenthesis
All plated steel construction

Coding System

When making an inquiry on Klixon® hermetically sealed motor protectors, be certain to specify the entire part number for your application, if known. The six digits following the series identification indicate your specific electrical and physical requirement.

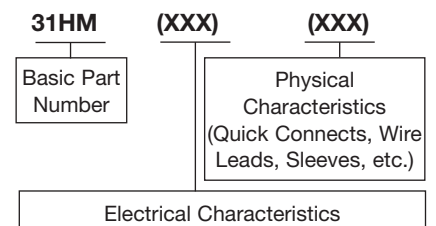



KLIXON | 34HM SERIES MOTOR PROTECTORS

Hermetically Sealed On-Winding, 3-Phase

PRODUCT OVERVIEW

The Klixon® 34HM on-winding motor protector is a 3-phase line break, automatic reset device which interrupts line current at the centerpoint of a WYE (Star) wound motor.

Compliant with European Directive 2002/95/EC Restrictions On Use of Hazardous Substances (RoHS)

Features & Benefits

- Protect WYE (Star) wound 3-phase motors from 1 to 6HP. Used in refrigeration compressors, submersible pumps and other restrictive environments.
- In-line protection in a small, rugged, welded construction. Low profile shape allows for close coupling to motor windings.
- Hermetic reliability designed for leakage rates less than 1×10^{-9} cc per second of air with 1 atmosphere pressure differential.
- Klixon® snap-action discs assure positive make and break action and controlled temperature differential.
- Designed for low and high side pressure applications.

This protector is designed to protect 3-phase refrigeration and air conditioning compressor motors from excessive winding temperature; however, applications may be made to any WYE wound 3-phase motors where environmental conditions require a hermetic seal. The low profile permits the device to be installed directly on motor windings for closely coupled temperature monitoring, thus enhancing over-temperature protection against loss of refrigeration charge, low voltage locked rotor, and secondary single-phasing (loss of phase).

The 31HM, 32HM, and 33HM are designed to reduce installation costs by replacing pilot control systems with a simple, economical, compact device.

Maximum Recommended Locked Rotor Current

Standard Series			
1XX	2XX		3XX
230V	380V	460V	575V
90A	55A	45A	35A

High Capacity Series			
4XX	5XX		6XX
230V	380V	460V	575V
105A	80A	75A	60A

Current ratings are based on life test data which has demonstrated high reliability at 5K cycles (standard series) and 2K cycles (high capacity series) at 0.7 power factor on Sensata life test boards.

These capacities are intended as a guide for application work.

The basic element of the 34HM is the famous Klixon® Snap Acting Disc

HEATING, VENTILATION & AIRCONDITIONING

34HM Hermetic Motor Protector

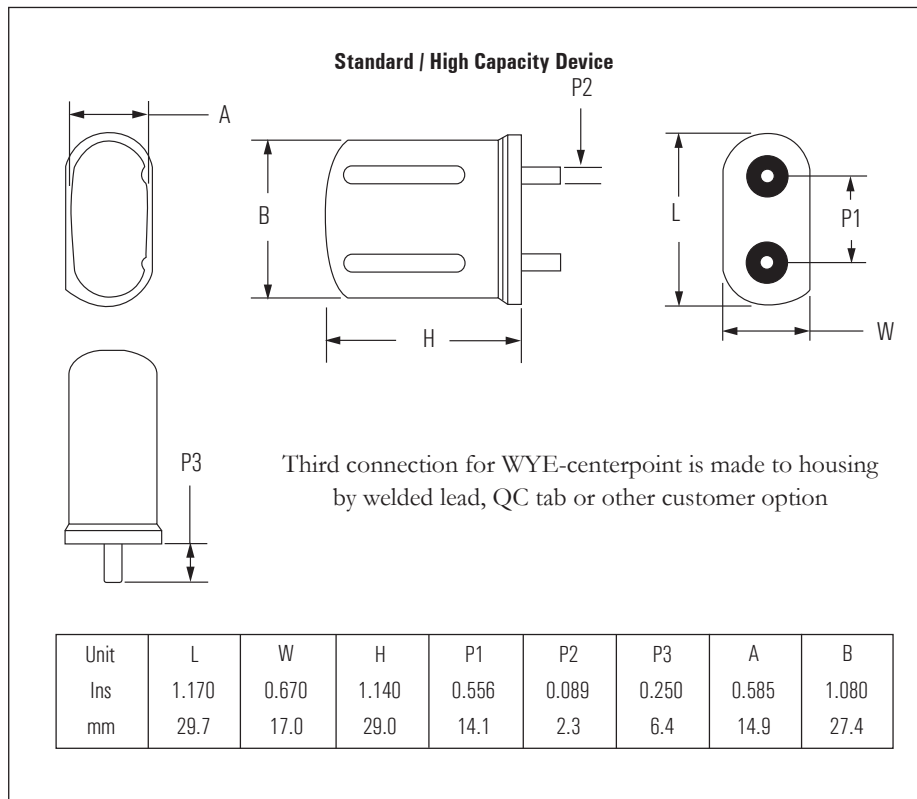

Standard Operating Temperature

Opening Temperature
95°C to 175°C (5°C increments)
Tolerance ±5°C

Closing Temperature
to suit application
Tolerance ±9°C

Pressure Rating
1600 PSIG
110 bar

UL & Canadian-UL File # E15692
CQC File # CQC05002011992
KEMA (ENEC) File # 2018218.08

Electrical Schematic

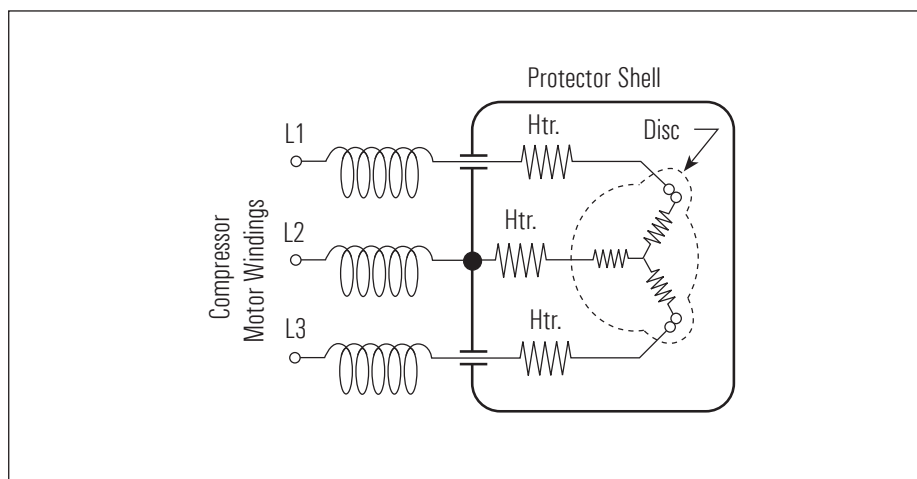

Coding System

When making an inquiry on Klixon® hermetically sealed motor protectors, be certain to specify the entire part number for your application, if known. The six digits following the series identification indicate your specific electrical and physical requirement.

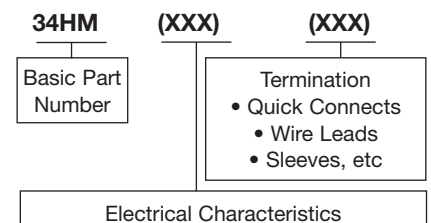



KLIXON® | 35HM SERIES MOTOR PROTECTORS

Hermetically Sealed On-Winding, 3-Phase

PRODUCT OVERVIEW

The Klixon® 35HM on-winding motor protector is a 3-phase line break, automatic reset device which interrupts line current at the centerpoint of a WYE (Star) wound motor.

Compliant with European Directive 2002/95/EC Restrictions On Use of Hazardous Substances (RoHS)

Features & Benefits

- Protect WYE (Star) wound 3-phase motors from 4 to 10HP. Used in refrigeration compressors, submersible pumps and other restrictive environments.
- In-line protection in a small, rugged, welded construction. Low profile shape allows for close coupling to motor windings.
- Hermetic reliability designed for leakage rates less than 1×10^{-9} cc per second of air with 1 atmosphere pressure differential.
- Klixon® snap-action discs assure positive make and break action and controlled temperature differential.
- Designed for low and high side pressure applications.

This protector is designed to protect 3-phase refrigeration and air conditioning compressor motors from excessive winding temperature; however, applications may be made to any WYE wound 3-phase motors where environmental conditions require a hermetic seal.

The low profile permits the device to be installed directly on motor windings for closely coupled temperature monitoring, thus enhancing over-temperature protection against loss of refrigeration charge, low voltage locked rotor, and secondary single-phasing (loss of phase).

The 35HM is designed to reduce installation costs by replacing pilot control systems with a simple, economical, compact device.

Maximum Recommended Locked Rotor Current

Standard Series			
1XX	2XX		3XX
230V	380V	460V	575V
150A	100A	85A	60A

High Capacity Series			
4XX	5XX		6XX
230V	380V	460V	575V
240A	175A	145A	100A

Current ratings are based on life test data which has demonstrated high reliability at 5K cycles (standard series) and 2K cycles (high capacity series) at 0.7 power factor on Sensata life test boards. These capacities are intended as a guide for application work.

The basic element of the 35HM is the famous Klixon® Snap Acting Disc

HEATING, VENTILATION & AIRCONDITIONING

35HM Hermetic Motor Protector

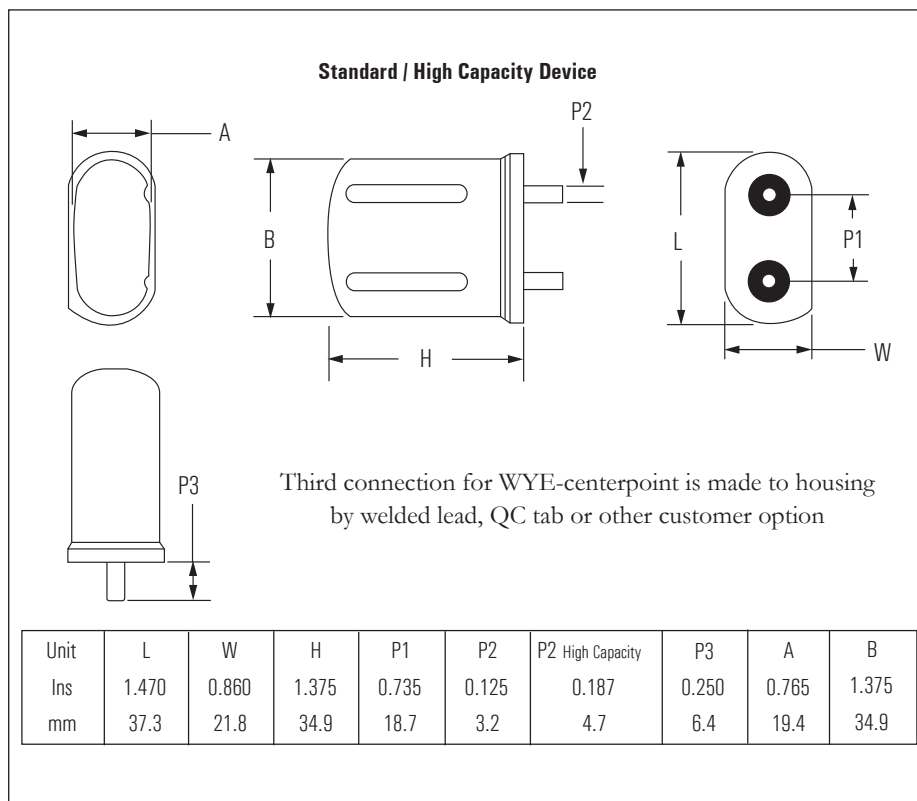

Standard Operating Temperature

Opening Temperature
95°C to 175°C (5°C increments)
Tolerance $\pm 5^\circ\text{C}$

Closing Temperature
to suit application
Tolerance $\pm 9^\circ\text{C}$

Pressure Rating
1600 PSIG
110 bar

UL & Canadian-UL File # E15692
CQC File # CQC05002011992
KEMA (ENEC) File # 2018218.08

Electrical Schematic

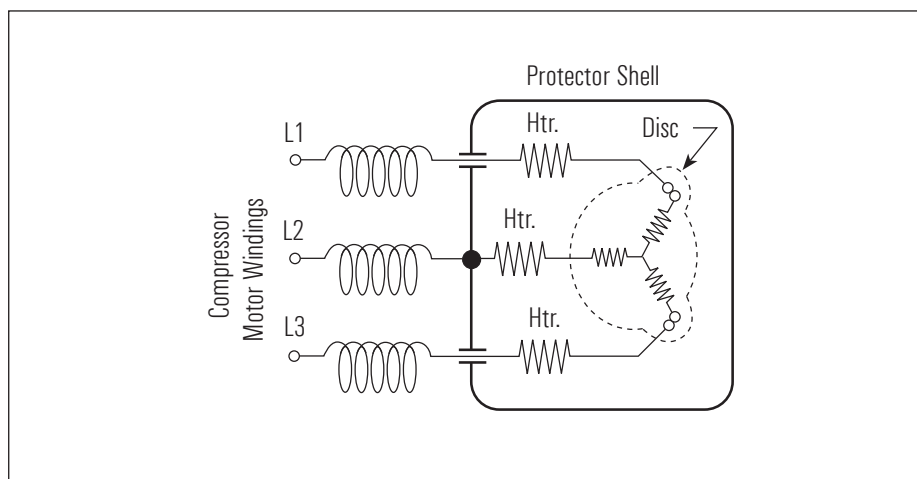

Coding System

When making an inquiry on Klixon® hermetically sealed motor protectors, be certain to specify the entire part number for your application, if known. The six digits following the series identification indicate your specific electrical and physical requirement.

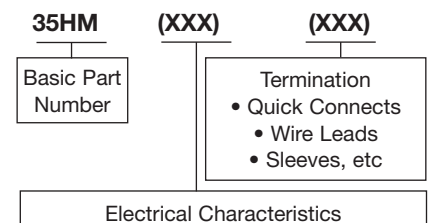



KLIXON® | 37HM SERIES

MOTOR PROTECTORS

Hermetically Sealed On-Winding

PRODUCT OVERVIEW

The Klixon® 37HM on-winding motor protector is a 3-phase line break, automatic reset device which interrupts line current at the centerpoint of a WYE (Star) wound motor.

Compliant with European Directive 2002/95/EC Restrictions On Use of Hazardous Substances (RoHS) + CAD FREE.

Features & Benefits

- Protect WYE (Star) wound 3-phase motors from 1 to 6-7HP. Used in refrigeration compressors, submersible pumps and other restrictive environments.
- In-line protection in a small, rugged, welded construction. Low profile shape allows for close coupling to motor windings.
- Klixon® snap-action discs assure positive make and break action and controlled temperature differential.
- Designed for low and high side pressure applications.

This protector is designed to protect 3-phase refrigeration and air conditioning compressor motors from excessive winding temperature; however, applications may be made to any WYE wound 3-phase motors where environmental conditions require a hermetic seal. The low profile permits the device to be installed directly on motor windings for closely coupled temperature monitoring, thus enhancing over-temperature protection against loss of refrigeration charge, low voltage locked rotor, and single-phasing (loss of phase).

The 37HM is designed to reduce installation costs by replacing pilot control systems with a simple, economical, compact device.

Standard Series		
1XX	2XX	3XX
230V	460V	575V
90A	45A	35A

High Capacity Series		
4XX	5XX	6XX
230V	460V	575V
105A	75A	50A

Maximum Recommended Locked Rotor Current

Current ratings are based on life test data which has demonstrated high reliability at 0.7 power factor on Sensata test boards. These capacities are intended as a guide for application work. These capacities are intended as a guide for application work.

The basic element of the 37HM is the famous Klixon® Snap Acting Disc

HEATING, VENTILATION & AIRCONDITIONING

37HM Hermetic Motor Protector

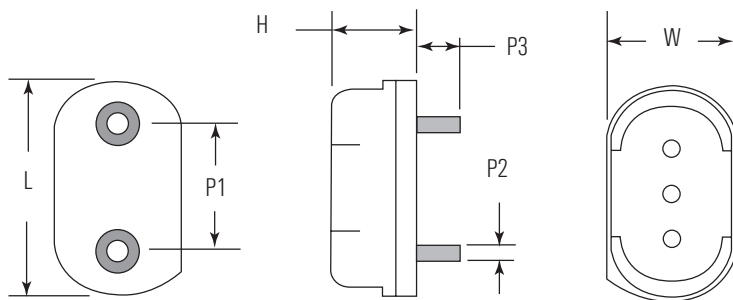

Third connection for WYE-centerpoint is made to housing by welded lead, QC tab or other customer option

Unit	L	W	H	P1	P2	P3
Ins	1.26	0.78	0.5	0.7	0.09	0.25
mm	32	20	12.7	17.8	2.3	6.4

Standard Operating Temperature

Opening Temperature

100°C to 180°C (5°C increments)
Tolerance ±5°C

Closing Temperature

to suit application
Tolerance ±9°C

Pressure Rating

1500 PSIG
105 bar

UL & Canadian-UL File # E15692
CQC File # CQC05002011992
KEMA (ENEC) File # 2018218.08

Electrical Schematic

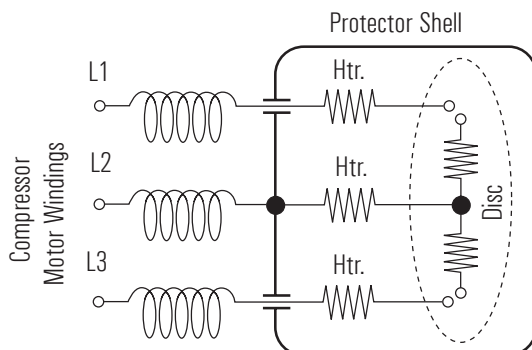

Coding System

When making an inquiry on Klixon® hermetically sealed motor protectors, be certain to specify the entire part number for your application, if known. The six digits following the series identification indicate your specific electrical and physical requirement.

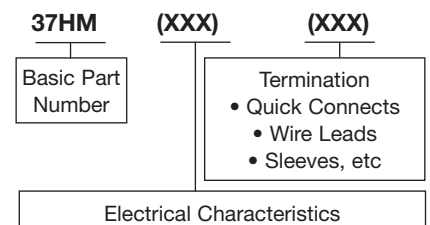

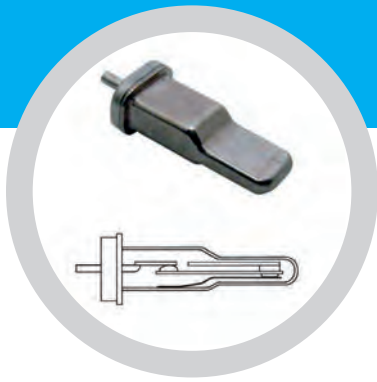

KLIXON | 7895 SERIES **MOTOR THERMOSTATS** *Hermetically Sealed On-Winding*

CONSTRUCTION

The basic element in the on-winding motor thermostat is the Klixon® snap-acting disc. The electrical circuit consists of the pin, insulated from the case by the glass-to-metal seal, connected to the stationary contact through the disc to the case. In the 7895 thermostat, the metal case is electrically hot and requires some method of insulation from the motor windings. Several custom configurations of insulation and terminations are available at slight additional cost.

Features & Benefits

- Small size and shape permits close coupling to motor windings for increased protection
- Hermetically sealed enclosure
- Simple, rugged all-welded construction has one moving part for trouble-free service
- Klixon® snap action thermal disc assures positive make and break action controlled temperature differential aid vibration resistance

Klixon® 7895 on-winding motor thermostats are designed to protect hermetically-sealed compressor motors from excessive winding temperatures. A positive refrigerant seal combined with small tubular construction allows these thermostats to be installed directly in the motor windings for precise monitoring of winding temperatures. As a result, the compressor manufacturer can choose a thermostat that will allow the motor to be safely rated to its maximum capacity.

Installation

Maximum heat transfer from the motor windings to the thermostat is the key to optimum performance. In many cases, the total surface of the device can be utilized by inserting its entire length within the stator winding. Good performance is also achieved by lacing the protector to the top of the windings, making sure that the surface of the case is in close contact with the stator windings. The thermostat may be varnished dipped and baked with the entire assembly.

Pilot Circuit Operation

The 7895 thermostat is used as a pilot duty control to protect a motor from overheating in a running overload condition. When used alone, it cannot protect against locked rotor since its response time is not fast enough to follow the very rapid temperature rise of the windings. The Klixon 8347 and 8348 supplementary overloads with their quick response to locked rotor current, can be used to supplement the 7895 thermostat. These overload devices trip very quickly for the first several cycles, allowing enough time for the heat generated in the windings to reach the thermostat which then takes over as the controlling element. This combination is used to protect both single-phase and three-phase motors.

HEATING, VENTILATION & AIRCONDITIONING

Dimensions

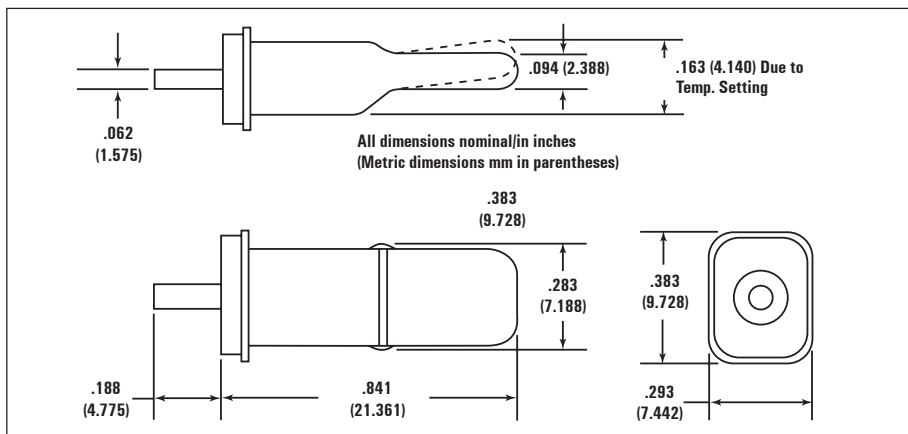

Wire Lead Insulations

Dacron Mylar Dacron
600V – 105°C temperature rating – 18 AWG

Dacron Teflon Mylar Dacron
600V – 105°C temperature rating – 20 AWG

Teflon
300/600V – 200°C temperature rating – 22 AWG

Teflon
300V – 200°C temperature rating – 18 AWG

Insulation Sleeve Material

Mylar – .004” thick

Typical Custom Configurations



Operating Temperatures

75°C to 135°C

Standard Tolerances

±5°C open, ±11°C close

Standard Differential

22°C nominal

Special Tolerances

±3°C open, ±5°C close

Special Differential

17°C nominal

VDE approved
7895-XXX-XXX

$\frac{2(2)}{250} \sim \frac{1(1)}{380} \sim \frac{5.2(5.2)}{24}$

Class 1, T200

Mylar over Teflon – .007” thick

(.004” Mylar/.003” Teflon)

Terminations

Female flag quick connect 1/4” open end terminal for #10 screw, #10 eyelet

UL and CSA Rated

125 VA, 24 VAC
345 VA, 110-600 VAC
(limited to the lead wire voltage rating if less than 600 VAC).

Engineering Test Samples

To order test samples please supply the following information:

1. Opening temperature
2. Temperature differential
3. Tolerances desired on opening and closing temperatures
4. Voltage
5. Lead type, size and length
6. Insulation required

Coding System

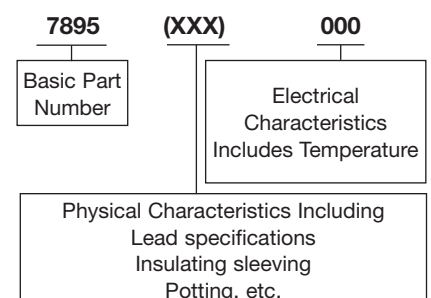



KLIXON | 7HT, 8HT, 9HT&14HT SERIES PTC SOLID STATE HEATERS

PRODUCT OVERVIEW

The 7, 8, 9, and 14HT series crankcase heaters are multi-voltage, in-well PTC devices. They are designed to eliminate compressor damage resulting from freon mixing with oil by creating a temperature differential between the oil and migrating freon.

Key Features

- Energy saving self-regulating PTC heaters - no thermostat required
- Multi voltage capability / 240-600 Vac
- Solid state reliability
- Allows higher compressor E.E.R.'s
- Output increases as ambient decreases
- Self compensates for voltage variations
- PTC element for long life
- UL tested for:
 - Temperature
 - Aging/Endurance
 - Humidity
 - Stability

The in-well design provides excellent thermal coupling to the crankcase oil, minimizing heat loss to the environment. The multi voltage capability eliminates the costly need for inventorying additional heaters.

Self-regulating PTC provides for power reduction with temperature rise, without the need for switch controls or thermostats.

All 7, 8, 9, & 14HT crankcase heaters are manufactured under statistical process control and are 100% tested at 125% of rated voltage for conformance to specifications.

UL File No. E49372, SA5202

CSA File No. LR46861, LR80111

Coding System

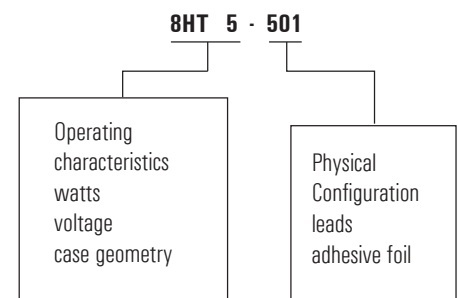

Rating

Part No.	Wattage @ 0°C H ₂ O	Voltage
7HT5-XXX	25 - 35W	240-600 VAC
8HT5-XXX	25 - 35W	240-600 VAC
9HT5-XXX	40 - 55W	240-600 VAC
14HT6-XXX	35 - 45W	240-600 VAC

7HT/8HT/9HT/14HT Typical Power Output vs. Oil Temperature Curves

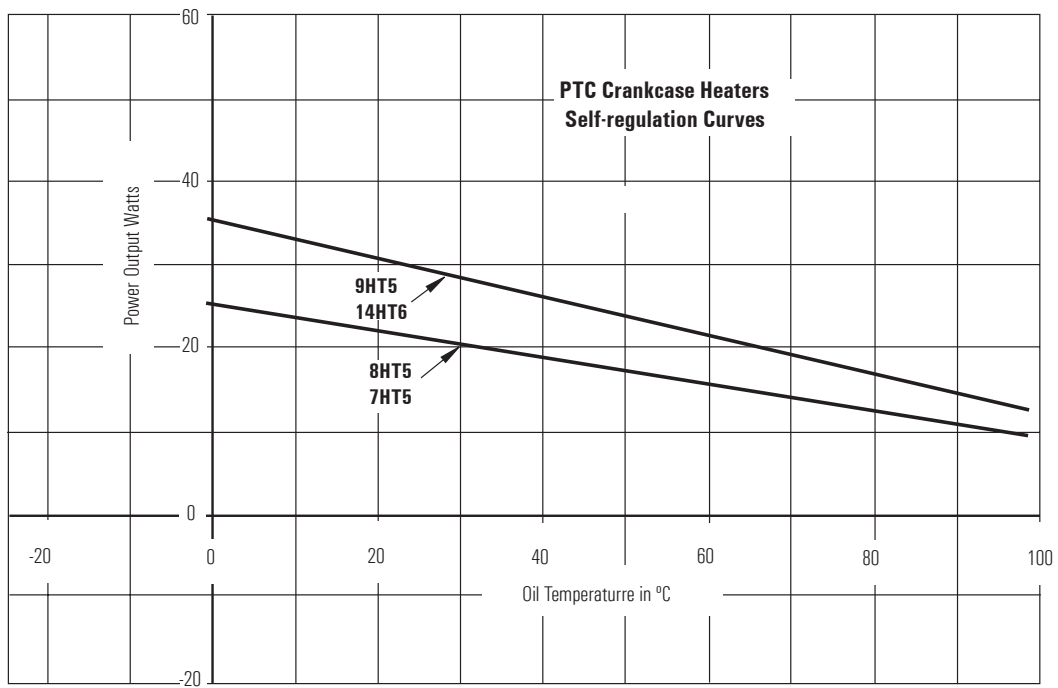

7HT, 14HT Series

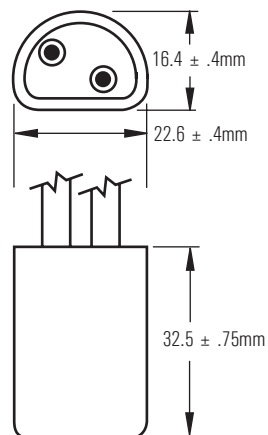

8HT, 9HT, Series

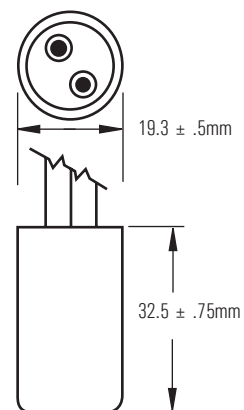

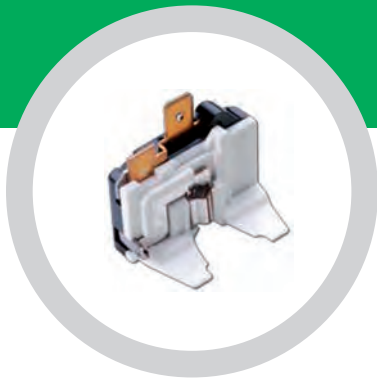

KLIXON | 4TM THERMAL MOTOR PROTECTORS



FEATURES

- Plug-on thermal motor protector for compressors
- Protects compressors for refrigerators, freezers, dehumidifiers, water coolers, vending machines, and similar refrigeration applications
- Compatible with PTCR starters and electro-mechanical relays
- Product designed and manufactured in environment of Total Quality Control
- Applicable to compressors manufactured around the world
- Conforms with worldwide certification agency standards

Benefits

• Cost

The 4TM's patented plug-on feature and our fully automated manufacturing module provide 4TM customers with the minimum *total installed cost*.

• Quality

ST has designed quality into the 4TM product and process to meet a higher quality standard based on Statistical Process Control techniques. Each 4TM production lot is accompanied by a "Certified Quality Report." This document certifies, based on statistical methods, the lot's compliance with temperature, trip time and other specifications. Supplying certified devices eliminates our customer's need for incoming inspection of the 4TM.

• Performance

The basic function of the 4TM is to protect the motor in a refrigeration compressor from overheating, resulting from locked rotor or running overload conditions. The 4TM provides this protection by sensing the current and temperature of the motor. The fundamental actuation principle incorporates a noncurrent carrying snap-acting disc, which is located above the heater element. (REFER TO BACK PAGE FOR REFERENCE DRAWINGS). In addition to radiant heat generated from the heater, compressor shell, and ambient, the disc senses the heat from the metal pin carrying line current through the hermetic terminals. When the disc snaps, it actuates the spring arm located above the disc, opening the contact circuit - which shuts off the compressor motor. The operating parameters of the 4TM are not affected by contact wear because

the contacts are not part of the resistance circuit and are not part of the temperature calibration mechanism. The patented design features of the 4TM have resulted in the following performance and reliability improvements:

- **Longer off-times for better matching and compatibility with PTCR starters**
- **Better repeatability of trip time and ultimate trip**
- **Minimum temperature drift versus life cycles**
- **Excellent resistance to physical and thermal shock**

Refrigeration Compressor Motor Protector Application Procedure

Test Conditions:

The 4TM is normally applied on refrigeration compressors.* There are several standard or typical types of fault conditions, for which a thermal protector's characteristics should be appropriate:

• Pull Down

The protector must have sufficient current carrying capacity to allow the compressor to run under heavy load conditions. Typically, the heaviest load occurs under a pull down condition of a refrigerator cabinet. This is a condition where under the hottest specified ambient, a refrigerator is required to pull down from a soaked out room ambient to reach its designed refrigerating temperature in the main compartment and freezing temperature in the freezer compartment. This is generally required to take place in a limited number of hours, and the thermal protector must not trip and prevent this from happening. In order to

select a 4TM which has sufficient capacity to meet this requirement, the following information is needed:

- Maximum current the compressor draws during pull down
- Shell temperature under the 4TM and air temperature over the 4TM when maximum current draw occurs
- Maximum shell temperature during pull down
- Current and air temperature under the cover when maximum shell temperature occurs

This will be used to select a 4TM heater type and opening temperature which allow sufficient current carrying capacity to achieve pull down, even with a minimum opening temperature 4TM.

• Running Overload

There are two running overload conditions which can cause motor overheating, and which can happen relatively easily: the condenser fan can be stopped or its air flow blocked, or the door can be left open causing continuous running of the compressor. To prevent motor overheating, the current under each condition should be recorded along with the shell temperature and air temperature over the protector at the point where it is desired that a protector trip occurs. This point is generally related to the maximum motor temperature allowed by the compressor manufacturer; and the 4TM, even with the maximum opening temperature, should not permit operation of compressor beyond that point.

• Locked Rotor

The failure of the rotor to turn when the motor is energized will cause a large current inrush. The 4TM thermal protector should trip in a matter of seconds under this condition; cycle for an extended period of time (15 days required by UL); and limit the shell temperature to under 150°C (per UL) and motor winding temperature to the maximum value specified by the compressor manufacturer. Locked rotor testing is generally conducted at nominal voltage, some percent less than nominal and some percent more than nominal. In each case, the inrush current needs to be recorded along with the observed rate of rise of the motor winding. If an electromechanical relay is used, the total line current is used. If a PTCR starter is used, the total line current is recorded, the time at which the PTCR switches is noted, and the main winding only current is recorded. The “hot” current, or current recorded at the time of a desired protector trip, is also recorded. The required number of days of locked rotor cycling should also be stated.

• Power Outage

A special case of a locked rotor trip occurs when a power outage occurs for a short interval (seconds), and when a PTCR starter is used. If the compressor was running prior to the outage, the compressor would try to restart when power was restored; but the compressor motor would not be able to rotate due to high head pressure, and locked rotor current would be imposed on the motor and thermal protector, causing a protector trip. The PTCR starter and protector would then begin to cool.

When the protector resets, it is desirable to have the PTCR starter cooled to allow sufficient time of high start winding current to accelerate the motor. Under this condition, it is useful to know how much off-time is desired from the protector to allow the PTCR to cool.

**Failure to properly apply the 4TM could result in actuation of the device when the compressor should be operating, or overheating of the motor during a fault condition.*

Technical and application assistance is available from our Marketing/Sales professionals located throughout the world.

Certification Agency Information

- UNDERWRITERS LABORATORIES, INC. - Recognized component, XEWR2, file E15962, issued 10-15-85
- CANADIAN STANDARDS ASSOC. - Certified file LR 11372-82C, issued May 14, 1986
- VDE - File No. 4464.4-4510-1010/A1C Approval Document No. 2427 UG 250 VAC, 16 (16 max 16) AMPS Overheat Protection, T175, 1.0K/min.
- SEMKO - T150, rated 250 VAC, 20 AMPS max.
- BEAB - (CO920) 250 VAC, 16 AMPS max.
- EN - 60730-2-4 250VAC, 16 AMPS max.

4TM Thermal Protector Device Coding

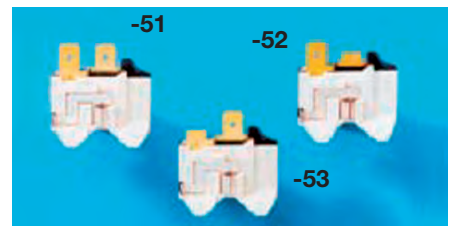
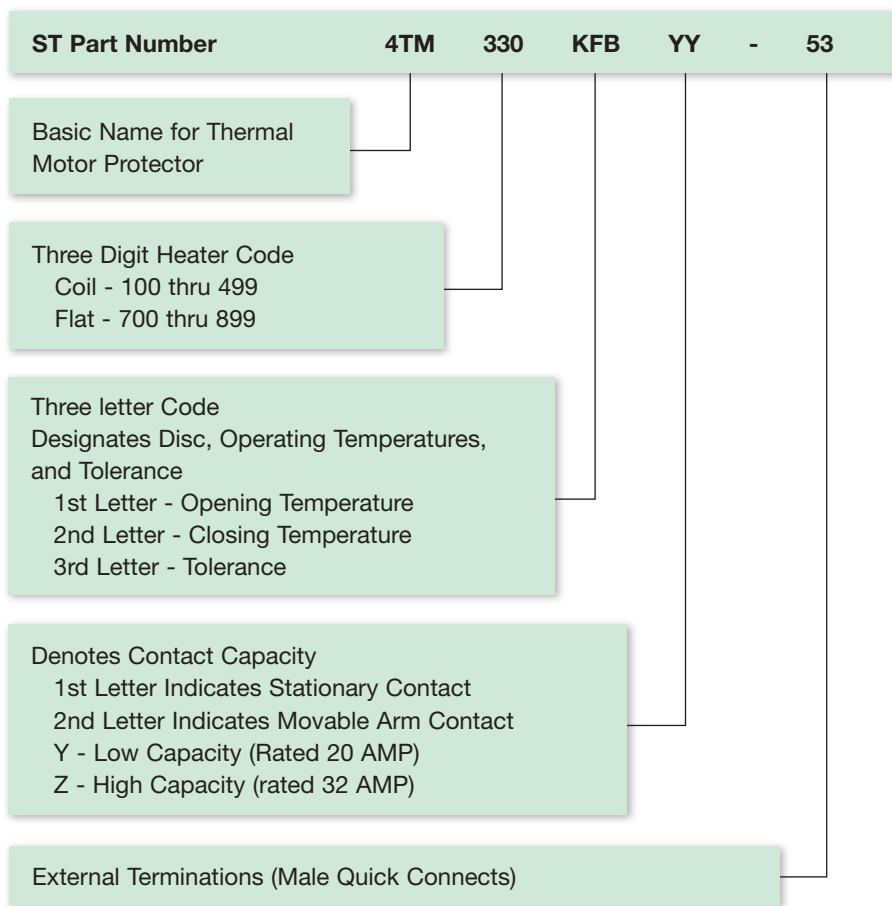

This guideline is intended to direct users toward a proper selection of contact capacity for specific applications and judgement of acceptability of cycle rate on an application relative to their specific goals for cycle life reliability. It presumes that the heater capacity has not been exceeded, and only published combinations of open and reset temperatures are used.

The expected life of a given combination of 4TM and motor may well exceed the above guidelines by a considerable amount. Estimates of life of a given 4TM rating, in combination with a given compressor, may be obtained from a ST Sales/Marketing representative. It is incumbent upon the user to determine the reliability of the combination by actual locked rotor life test of the system.

Notes on Code

Heaters. Coiled heaters are preferred for PTCR-starter type applications because they provide longest off time; however, their ratio of first cycle trip time amps to ultimate trip amps is greater than flat heaters (approx. 4:1). Coiled heater series can cover a range of U.T.A. at 71°C from 0.7 amps to 5 amps.

Flat heaters are preferred for relay type applications due to their narrower ratio

Contact Capacity (Cycle Life Guidelines)

The 4TM is designed to achieve a minimum of 10,000 cycles as defined by a Weibull analysis of test results. A failure is defined as open or permanently closed circuit, and a change in open temperature of greater than $\pm 5^{\circ}\text{C}$ or a change in reset temperature of $\pm 9^{\circ}\text{C}$ from the device's original value.

Test conditions are:

Contact	Operating Voltage	Max Current	Power Factor
ZZ	120	32 Amps	65%
YY	240	20 Amps	65%

of trip time current to ultimate trip current (approx. 3:1). Flat heaters can cover a range of U.T.A. at 71°C from 0.9 amps to 8 amps.

Temperatures. Below is a list of standard operating temperatures, and each has $\pm 5^{\circ}\text{C}$ tolerance on open temp and $\pm 9^{\circ}\text{C}$ tolerance on reset temp. Consult

your local ST Sales/Marketing representative for special requirements.

4TM Operating Temperatures

Temperature Code	Nominal Open	Nominal Close
JDB	100.0	52.0
KDB	105.0	52.0
KFB	105.0	61.0
LDB	110.0	52.0
LFB	110.0	61.0
MDB	115.0	52.0
MFB	115.0	61.0
MHB	115.0	69.0
NFB	120.0	61.0
NHB	120.0	69.0
PFB	125.0	61.0
PHB	125.0	69.0
REB	130.0	57.0
RFB	130.0	61.0
RHB	130.0	69.0
RLB	130.0	78.0
SFB	135.0	61.0
SHB	135.0	69.0
SLB	135.0	78.0
TFB	140.0	61.0
THB	140.0	69.0
TLB	140.0	78.0
UFB	145.0	61.0
UHB	145.0	69.0
ULB	145.0	78.0
VFB	150.0	61.0
VHB	150.0	69.0
VLB	150.0	78.0
VPB	150.0	87.0
WHB	155.0	69.0
WLB	155.0	78.0
WPB	155.0	87.0
XHB	160.0	69.0
XLB	160.0	78.0
XPB	160.0	87.0

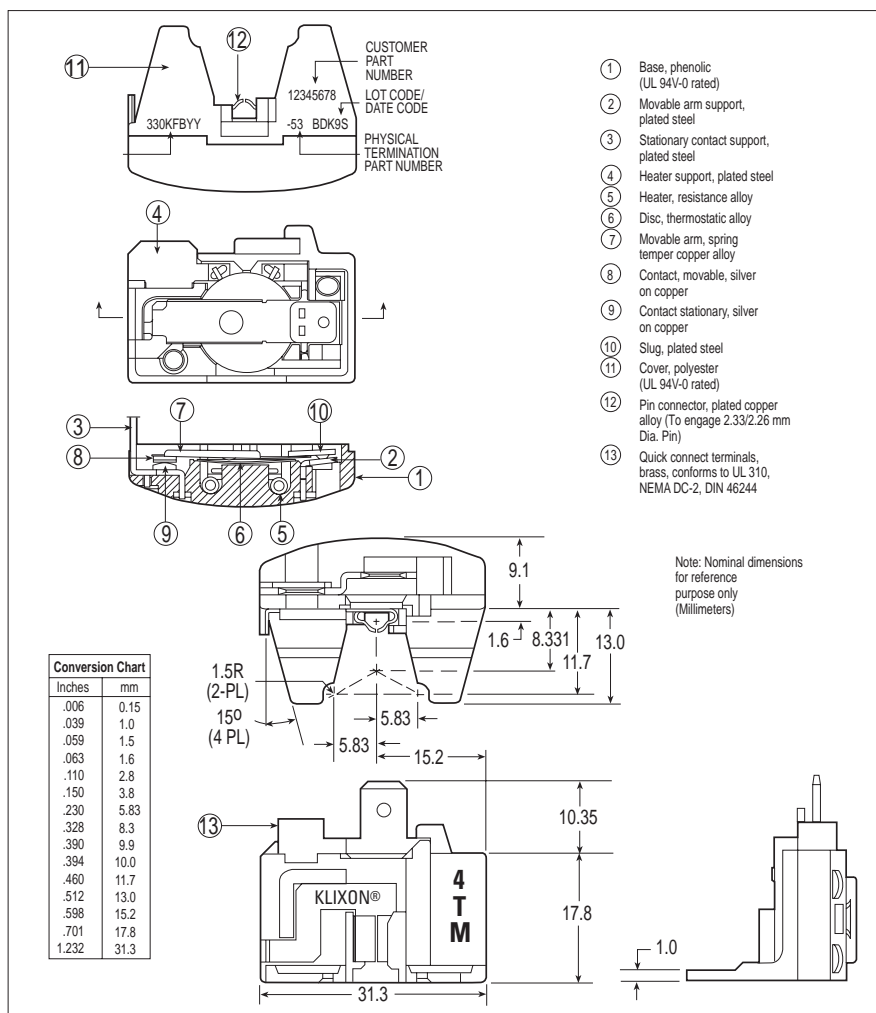



KLIXON | MOTOR STARTER- PROTECTOR COMBO (MSC) REFRIGERATION PACKAGE

Compact, Reliable, Low Power Consumption

PROVEN TECHNOLOGY

The Klixon® MSC refrigeration package is a compact motor starter and motor protector package that dissipates less than 2 watts under typical operating conditions.



Overview

The MSC by Sensata Technologies serves as a combination control that:

- Uses compact metal can motor protector and solid state PTC motor starter
- Includes Internal Back-up Protection System for the PTC motor starter
- Available for both RSIR and RSCR applications (Contact Sensata for alternate configurations)
- Plugs directly onto compressor terminal pins
- Dissipates less than 2 watts under typical operating conditions

Features

- Applicable to fractional horsepower compressors used in residential refrigerators and freezers, and similar refrigeration applications
- Utilizes ceramic PTC (Positive Temperature Coefficient) thermistor element to energize / de-energize motor start windings
- Available for 120 and 220 volt applications
- Configurations available to suit most residential applications
- Less costly to install than discrete motor starter and protector components

Application Notes

1. The surface and terminals of the MSC device can reach high temperatures under typical running conditions. Any material in contact with the MSC and its terminals, including wire and quick-connect receptacle plastic insulation, should have a minimum temperature rating (UL RTI) of 105°C. Adequate spacing should be provided to insulate lower-rated materials from this heat source.
2. The MSC device should be protected from potential sources of liquid, such as the evaporator tray and water connections.
3. Certain materials, such as chlorine (Cl) containing gases, can degrade the characteristics of the MSC device. The MSC device should not be exposed to sulphur (S) or chlorine (Cl) containing gases, and must be kept away from materials that can generate them. In particular, avoid the use of polyvinyl chloride (PVC) insulation in contact with the MSC terminals.
4. The MSC device should not be exposed to hydrocarbon based materials, as they can cause a degradation in the PTC characteristics.
5. The final device configuration selection will determine the necessity for a secondary compressor relay cover and or supplemental retention requirements.
6. The installation force applied to the MSC device must be in parallel with the compressor feedthrough pins and must not exceed 20 kgf (44 lbs).

Configurations

- MSC Standard Multiple quick connect (QC) terminal configurations available; designed to be used with secondary compressor relay cover
- MSC One-Piece Connector 3.2 mm x 0.5 mm terminals for use with standard insulated connector; available for use with or without direct-mounted run capacitor
- MSC Two-Piece Connector 1/4" and/or 3/16" QC terminal configurations for use with standard insulated connectors; available for use with or without direct-mounted run capacitor
- MSC Terminal Board Multiple QC and screw terminal configurations available; designed to be used with secondary compressor relay cover

application notes

1. The surface and terminals of the MSC device can reach high temperatures under typical running conditions. Any material in contact with the MSC and its terminals, including wire and quick-connect receptacle plastic insulation, should have a minimum temperature rating (UL RTI) of 105°C. Adequate spacing should be provided to insulate lower-rated materials from this heat source.
2. The MSC device should be protected from potential sources of liquid, such as the evaporator tray and water connections.
3. Certain materials, such as chlorine (Cl) containing gases, can degrade the characteristics of the MSC device. The MSC device should not be exposed to sulphur (S) or chlorine (Cl) containing gases, and must be kept away from materials that can generate them. In particular, avoid the use of polyvinyl chloride (PVC) insulation in contact with the MSC terminals.
4. The MSC device should not be

exposed to hydrocarbon based materials, as they can cause a degradation in the PTC characteristics.

5. The final device configuration selection will determine the necessity for a secondary compressor relay cover and

or supplemental retention requirements.

6. The installation force applied to the MSC device must be in parallel with the compressor feedthrough pins and must not exceed 20 kgf (44 lbs).

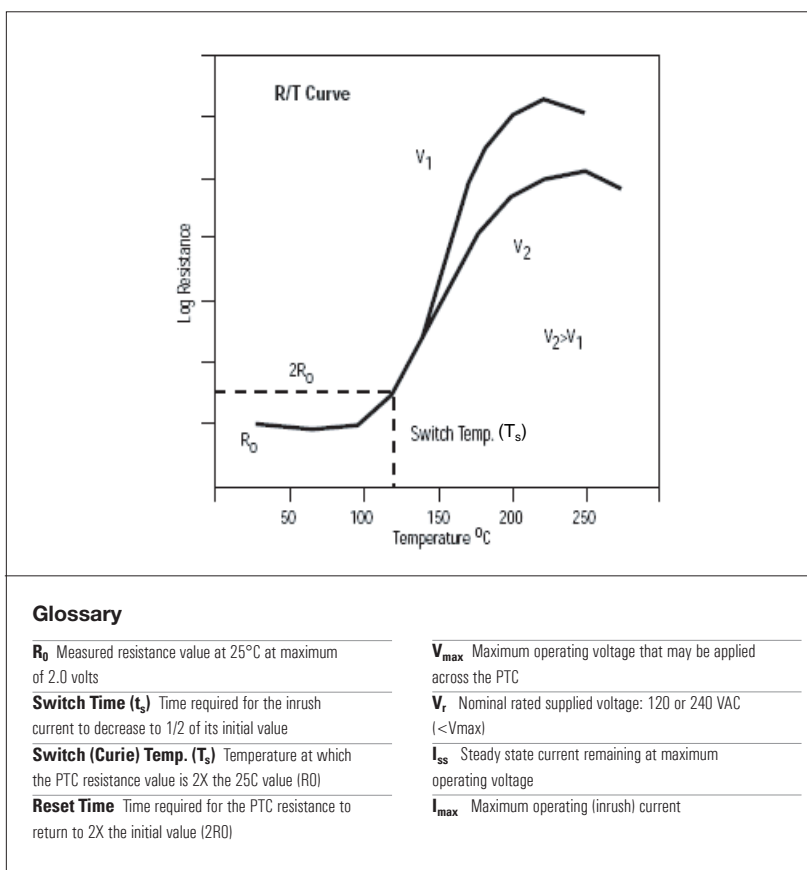

Part numbering system

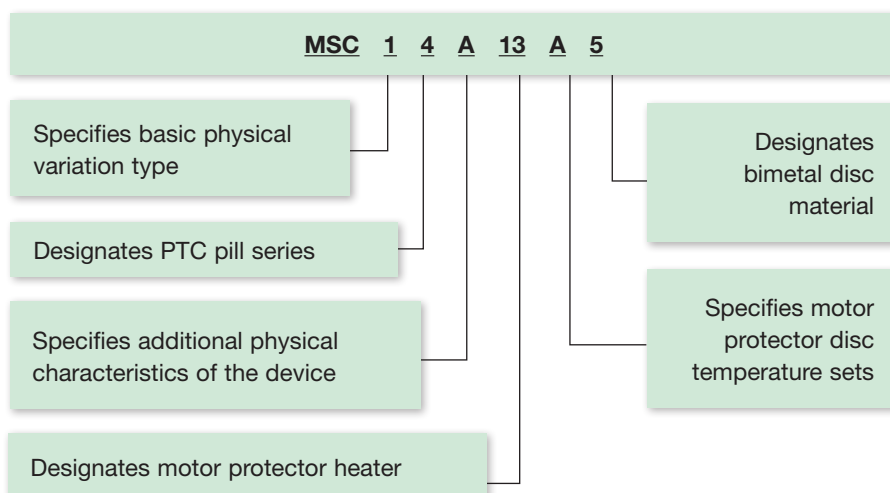

MAJOR HOME APPLIANCES

Electrical schematics

MSC STD

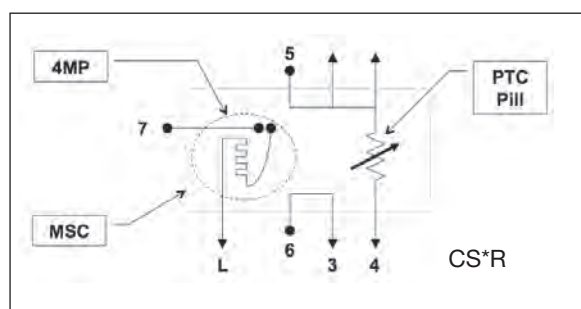
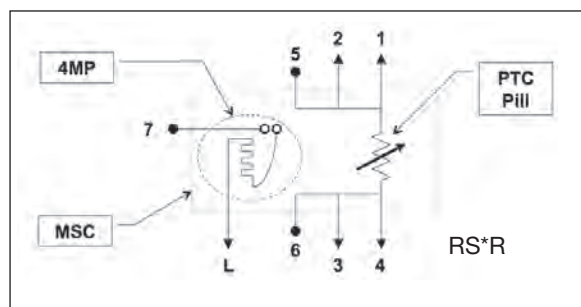

MSC 1-PC MSC 2-PC

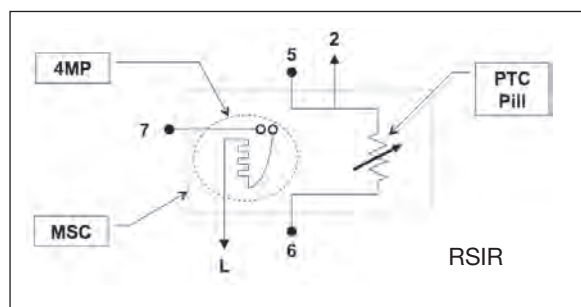
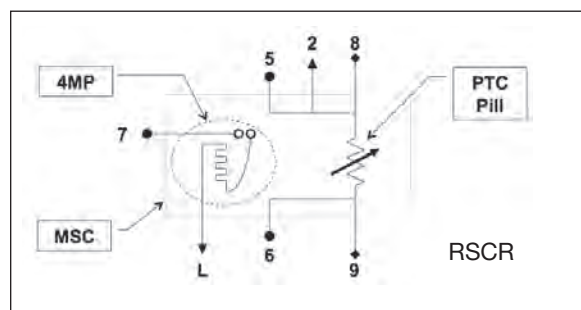

- ↑ Quick-connect terminal
- ↑ Pin connector
- ↑ Run Capacitor connector (outputs)

Specifications

General

Temperature Limits

Ambient Air: 0°C to 70°C

Electrical Requirements

120 or 240 VAC nominal voltage
(50 or 60 Hz)

Motor starter

Room Temperature Resistance

3.9W to 47W ratings available
±25% resistance tolerance

Switch Time

0.1 – 1.4s at 120 or 240 VAC

Reliability

500,000 cycles at maximum rated conditions of voltage and current

Motor protector

Device Actuation Temperatures

Open Temperature: 100°C to 160°C ± 5°C

Close Temperature: 55°C to 70°C ± 9°C

Temperature Differential: 60°C typical

Rated Hot Locked Rotor Current

120 VAC: 18.0 A maximum

240 VAC: 10.0 A maximum

60% power factor

Ultimate Trip Current

0.5 – 5.5 A @ 71°C

Endurance¹

Minimum of 15,000 cycles at maximum rated current at 120 and 240 volts, as predicted by Weibull analysis of the test data. This protection must be verified in the end application.

¹ A failure is defined as an open circuit or permanently closed circuit, rapid cycle (>3X normal rate), or by a change in the open or close temperature of more than 10% from the original values.

Agency certifications

UL/Canadian-UL Component Recognition:
File SA3745

KEMA/ENEC Compliance:

Certification # 2014531.01

IEC/EN 60730-2-4: 2007

IEC/EN 60730-2-10: 2007

IEC/EN 60079-15: 2005

IEC/EN 60335-1: 2001, clause 30.2.3

CQC Certification: 08002025660

RoHS compliant



KLIXON | PHENOLIC MOTOR PROTECTORS

WHY PROTECT MOTORS?

Overheating of motor insulation causes reduction in dielectric strength which can result in motor insulation damage or failure. The following are causes of motor overheating for which Klixon motor protectors can be applied to achieve protection:

- Prolonged running overload
- Locked rotor: mechanical / electrical failure to start
- Low line voltage
- High ambient temperature and lack of ventilation

Features

- Normally closed “make or break” Klixon® contact system, which is operated by a snap action disc, is sensitive to both temperature and current.
- Precision calibration – temperature calibrated and inspected under controlled conditions for dependable performance.
- Automatic or manual reset series available
- Easy to install
- UL recognized E15962
- CSA certified LR11372
- VDE certificate with production surveillance, overheating protector. 37 amperes maximum locked rotor 230 VAC, File 4464.4-4510-1013, License No. 3938 UG for 3/4” M.P. only.
- Inherent protection devices for approximately 1/2 to 5 h.p. motors used in applications such as industrial motors, agricultural equipment, well and sump pumps, fans, air conditioners, refrigerators, home appliances, etc.
- When properly applied, protector shuts off motor when temperature exceeds maximum safe level due to an overload or stalled (locked rotor) condition.

Klixon Phenolic Motor Protectors are equipped with a bimetallic snap acting disc, on which the contacts are mounted, and through which the current flows. If overheating conditions occur, the heating effect of the current flow through the Klixon disc and the influence of motor heat will cause the disc temperature to rise.

When the disc reaches the calibrated setpoint, the Klixon protector automatically opens and shuts down the motor, limiting the winding and shell temperature. When the motor has cooled to an acceptable operating level, allowing the protector to cool to its reset temperature, the Klixon protector resets automatically to a closed contact position allowing the motor to restart. Manual reset versions are also available for applications where automatic restarting may be hazardous to equipment or operations.

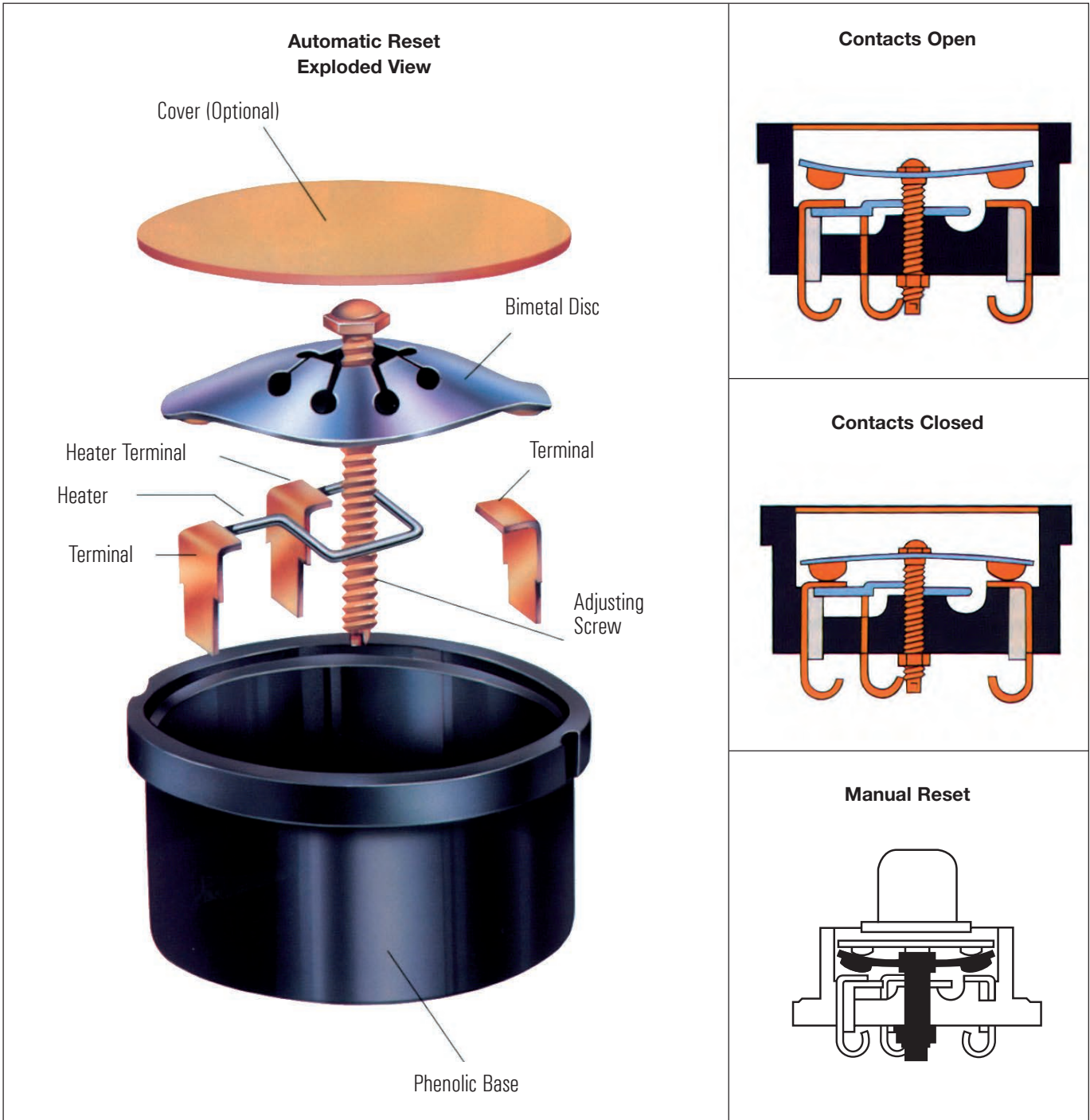

Dimensional Drawings
(Single Phase Types)

Round Base

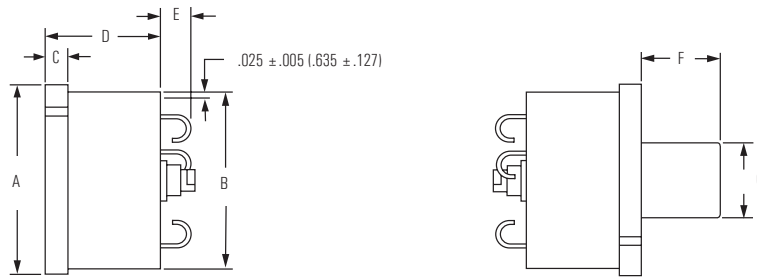

Type	Size	A	B	C	D	E Max.	F	G
MR	1/8"	1.031 ± .010	.970 ± .006	.125 ± .005	.625 ± .010	.171	23/64 ± 1/32	.375 ± .006
CR	1"	1.312 ± .010	1.218 ± .010	.125 ± .005	.640 ± .010	.218	31/64 ± 1/32	.442 ± .006
BR	1 1/4"	1.640 ± .010	1.555 ± .010	.156 ± .010	.930 ± .015	.313	27/64 ± 1/32	.442 ± .006
LR	1 1/2"	1.983 ± .010	1.881 ± .010	.154 ± .010	.830 ± .015	.375	15/32 ± 3/64	.781 ± .006

Eared Base

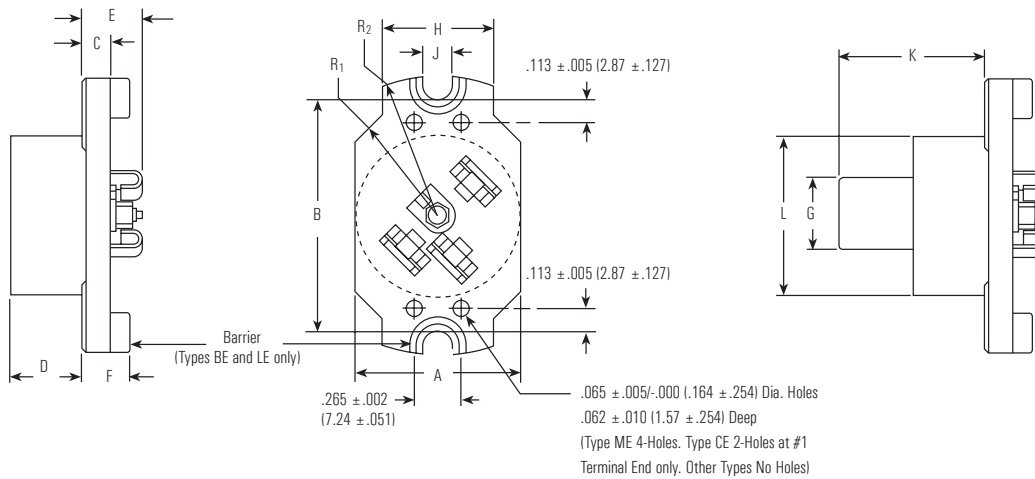

Type	Size	A	B	C	D	E	F	G	H	J	K	L	R ₁	R ₂
ME	1/8"	.970 ± .010	1.390 ± .015	.175 ± .010	.450 ± .015	.354	-	.436 ± .007	.625 ± .010	.176 ± .010	.953	.970 ± .006	.656 ± .010	.845 ± .010
CE	1"	1.187 ± .010	1.390 ± .015	.175 ± .010	.464 ± .015	.406	-	.440 ± .008	.625 ± .010	.176 ± .010	1.000	1.187 ± .010	.656 ± .010	.845 ± .010
BE	1 1/4"	1.594 ± .010	2.125 ± .010	.223 ± .010	.715 ± .010	.552	.332 ± .010	.440 ± .008	1.000 ± .010	.218 ± .010	1.180	1.552 ± .010	.844 ± .010	1.344 ± .010
LE	1 1/2"	1.875 ± .010	2.125 ± .020	.267 ± .010	.890 ± .010	.683	.517 ± .010	.781 ± .006	1.250 ± .010	.218 ± .010	1.370	1.875 ± .010	1.000 ± .010	1.344 ± .010

MAJOR HOME APPLIANCES

Type Code Structure for Single Phase Phenolic Motor Protectors

The following is an explanation of the type code which appears on each standard Klixon phenolic motor protector. By using this code, it is possible to determine the following size, type of base, terminals, heater, disc and contacts type and operating temperature.

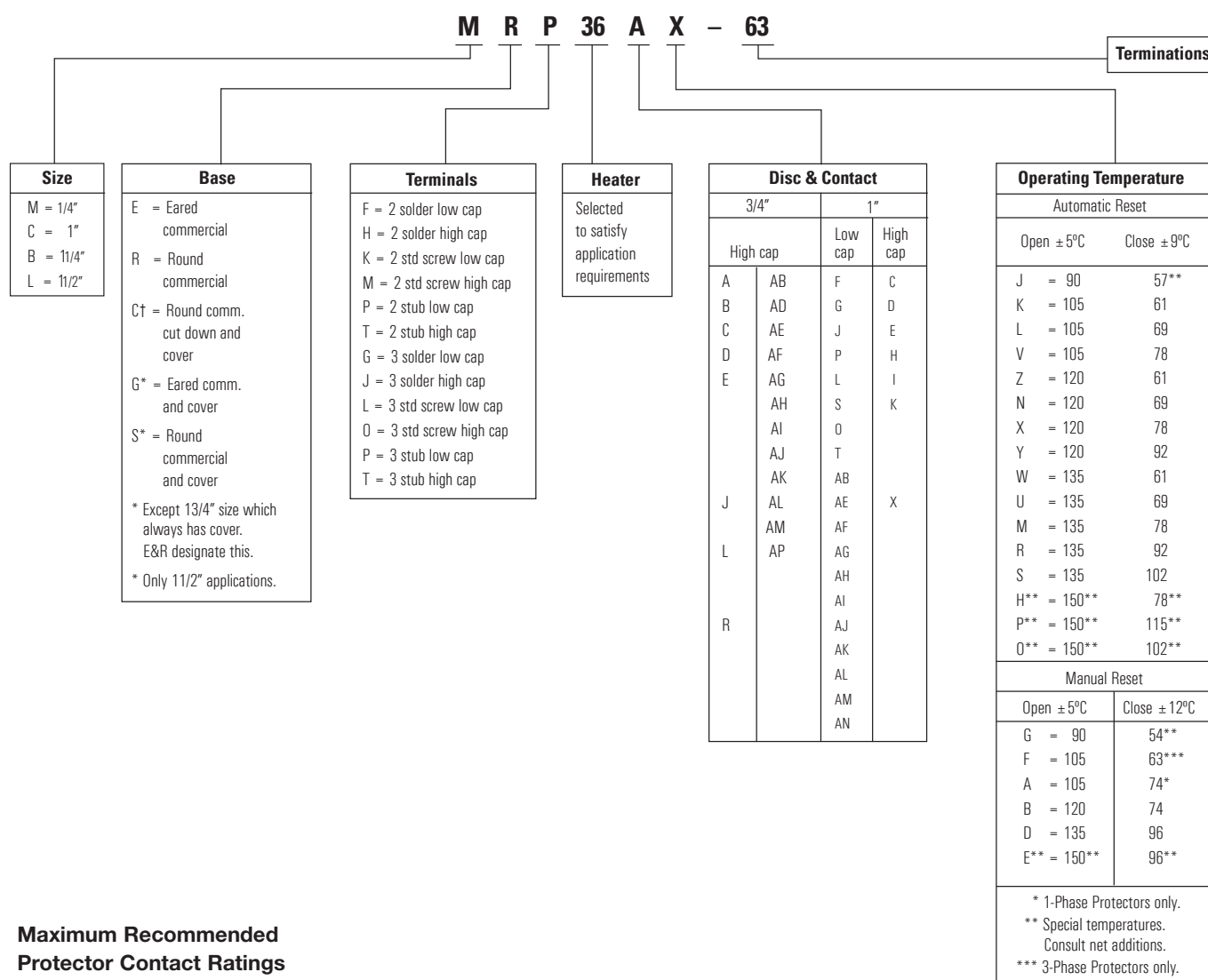

Maximum Recommended Protector Contact Ratings

This chart is used to determine protector size needed when making an application.

Size	Disc Contacts	Terminals	Max. Current V = 120	Max. Current V = 240
3/4"	HC	LC	32	25
3/4"	HC	HC	50	37
1"	LC	LC	40	30
1"	HC	LC	40	30
1"	LC	HC	40	30
1"	HC	HC	80	60
1 1/4"	STD	STD	135	100
1 1/2"	STD	STD	175	130

HC = High Capacity **LC** = Low Capacity **STD** = Standard Capacity
For reference only. Please contact Sensata for application assistance.

Application Worksheet

A sample worksheet provides the information needed for a proper application. It is not possible to apply a Klixon protector based on horsepower, amperage, or name plate data only.

Motor Data

A. Locked Rotor Requirements

1. Locked Rotor Current Cold: the current which exists the instant the motor is turned on.
2. Locked Rotor Current Hot: The current level that exists at end of 1st cycle test. Typically 10 to 30 seconds after motor is first turned on.
3. Time elapsed during above test to raise motor winding temperature from room temperature to around maximum allowed temperature for the UL class of motor insulation. An example would be, for a class A motor, 25°C to 175°C in 12.5 seconds.
4. Ambient Temperature During test: Room temperature (usually 25°C).

B. Running Overload Requirements

1. Load Current: With the motor running, the load on the motor is to be increased in small increments until the motor winding has completely stabilized at approximately 10°C below the maximum allowed by the UL class of the motor. An example would be, for a class A motor, the maximum allowed is 140°C. The motor winding temperature was completely stabilized at 130°C and the current draw at that time would be recorded.

- 2&3. Protector Location Temperatures: These temperatures are taken at the conclusion of the above load current test while the motor is running under the above load.
4. Ambient Temperature: Room temperature (usually 25°C).

C. Abnormal Conditions for Protection.

1. Max/min Ambient Temperatures: temperature in the surroundings of protector.
2. Max/min Line Volts: The highest and lowest voltages for which protection should be effective.
3. Other environmental considerations: i.e., exposed to agricultural weather conditions.

Name Plate Data

- | | | |
|---|-------|-------|
| A. Horsepower | _____ | H.P. |
| B. Voltage | _____ | Volts |
| C. Single or three phase | _____ | Phase |
| D. FLA (full load amps) | _____ | Amps |
| E. LRA (locked rotor amps) | _____ | Amps |
| F. Insulation class (UL/CSA) (indicate one) | _____ | ABFH |

Protector Requirements

- | | |
|------------------------------|-------|
| A. Automatic or manual reset | _____ |
| B. Round or eared base | _____ |
| C. Termination type | _____ |

Motor Data Required

- | | | |
|--|-------|-------|
| A. Locked rotor requirements | | |
| 1. Locked rotor current cold | _____ | Amps |
| 2. Locked rotor current hot | _____ | Amps |
| 3. Time required to raise motor winding to max. temperature | _____ | Sec |
| 4. Ambient temperature during test | _____ | Deg |
| B. Running overload requirements | | |
| 1. Load current required to stabilize main winding temp. at 10°C below maximum allowed | _____ | Amps |
| 2. Protector location temperature below protector surface | _____ | Deg |
| 3. Protector location temperature above protector (air temp) | _____ | Deg |
| 4. Ambient temp during test | _____ | Deg |
| C. Abnormal conditions for protection | | |
| 1. Max/min ambient temperatures | _____ | Deg |
| 2. Max/min line volts | _____ | Volts |
| 3. Other environmental considerations | _____ | |

Note: Application assistance available from Sensata.

Example of Motor Protector Performance Curves

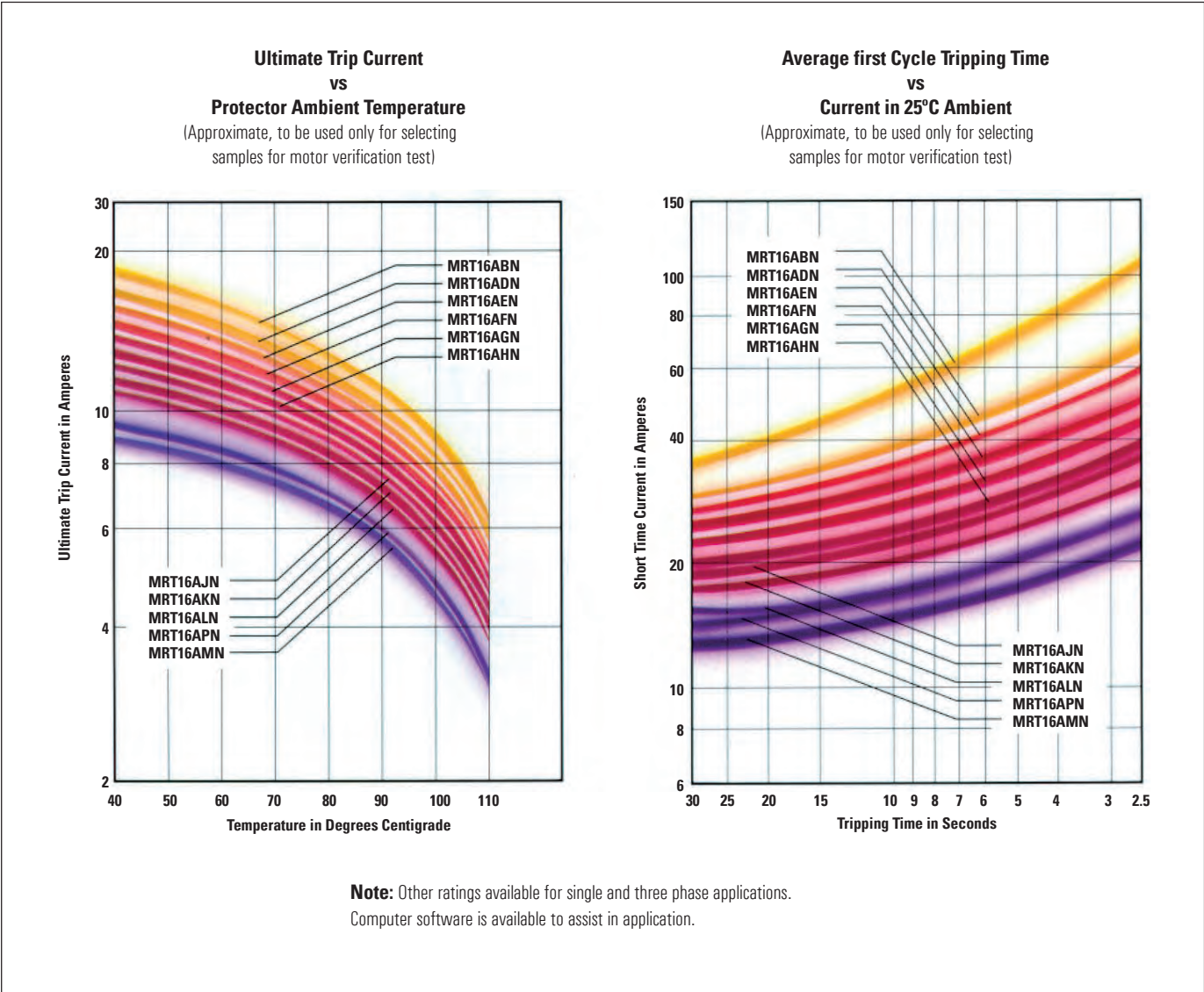



KLIXON | 1NT SERIES FIXED TEMPERATURE THERMOSTATS

WORLD CLASS PERFORMANCE

The 1NT has been designed to be applied for use in many HVAC and appliance products as either a regulating or over-temperature safety switch.

The 1NT uses Klixon® technology and is available in several mounting options. Sensata Technologies has been a leading global supplier of pressure sensors and switches for over 50 years.

Key Features

- ISO9001: 2000 certification
- Factory inspected for continuity and contact resistance
- Global sales and technical support
- Ambient temperature rating from -40°C to 240°C (-40°F to 464°F)
- 1NT base provides:
 - Low cost
 - High temperature capability
 - Clean processing
 - High impact strength
 - Low static generation
- Bi-metal disc is factory pre-set to achieve:
 - Operation at requested temperatures
 - Tamperproof settings
- Product innovations include:
 - Solid metal-to-metal terminal construction
 - Current free spring
 - One piece transfer mechanism
- Switch actions:
 - Automatic reset: Available with both normally open and normally closed switch logic
 - Manual reset: Mechanical reset device
 - Trip free manual reset: UL M2 class rating that resists consumer tampering
 - One shot: meets agency requirements for single operation device

Applications

- Microwave ovens
- Sandwich makers
- Rice cookers
- Hair dryers
- Fan heaters
- Vacuum cleaners
- Gas / electric furnaces
- Espresso machines
- Tea makers
- Automotive / truck



Available Constructions

<p>High Profile Construction Options shown: 90° - 1/4" Q.C. terminals with Surface mount flange</p> <p>Part Types by Construction</p> <ul style="list-style-type: none"> 1NT01 Auto Reset / Silver Contacts 1NT11 Auto Reset / Gold Contacts 1NT09 One Shot: -35°C (-31°F) Reset 1NT10 One Shot: 0°C (32°F) Reset 	<p>Low Profile Construction 4 Post Options shown: 45° - 1/4" Q.C. terminals with 4 post and flat Al cup</p> <p>1NT02 Auto Reset / Silver Contacts 1NT02TL Low Profile / One Shot 1NT20 Auto Reset / Gold Contacts</p>	<p>Manual Reset Construction Options shown: Flat 1/4" Q.C. terminals with Airstream mount cup</p> <p>1NT08 Manual Reset / Silver Contacts 1NT12 Manual Reset / Gold Contacts 1NT15 Trip Free MR / Silver Contacts 1NT19 Trip Free MR / Gold Contacts</p>
---	--	---

All dimensions mm (in.)

Numbering System

Part Number

1NTXX	E	L	-	XXXX
Part Type	Special Processing	Switch Type		ID Number
Consult Table Above	A Wire Lead Assy E Exposed Disc	L Limit* F Fan**		Unique, Customer Specific

Temperature Code

L	150	F	-	30
Switch Type	Operating Temp.	Temp. Scale		Differential
L Limit* F Fan**	Nominal Open Temperature	C Celcius		## Nom. Open to Nom. Close MR Manual Reset

* Limit switch opens on temperature rise
** fan switch closes on temperature rise

1NT Series Electrical Ratings

The 1NT series of thermostats has been recognized by safety agencies, including UL, Canadian-UL and KEMA. Agency ratings are presented below as a general guide. However, the temperature settings, mechanical, electrical, thermal and environmental conditions of the specific application may differ significantly from agency test conditions. Therefore, the user must not rely solely on the agency ratings presented here, but must perform its own testing

of the product to confirm that the thermostat selected will operate as intended over the useful design life of the user's applications.

UL and C-UL

Type	Max. Temp.		Cycles (X 1000)	Electrical Rating	
	°C	°F			
NT01, 02	204	400	100	120 Vac	0 - 9 amps 10 - 17 amps*
				240 Vac	0 - 5 amps 6 - 17 amps*
				277 Vac	7.2 amps
1NT08, 15, 08E**	204	400	1 + 5	240 Vac	25 amps
1NT09, 10	204	400	1-Shot	240 Vac 277 Vac	25 amps 7.2 amps
1NT11, 20	204	400	100	125 VA 30 Vdc	1 amp
1NT12, 19	204	400	1 + 5	125 VA	
1NT01E, 02E**	204	400	100	120 Vac	10 amps

* UL rated at these current levels at specific open/close temperatures. When applying to these electrical levels, nominal open/close temperatures must be considered to determine if the thermostat selected will operate as intended in the user's application. Please consult a Sensata Engineer for additional clarification.

** "E" means exposed disc.

KEMA

Type	Max. Temp.		Cycles (X 1000) <i>(unless otherwise specified)</i>	Electrical (Rating)*	
	°C	°F			
1NT01, 02	204	400	100	240 Vac	0 - 5 amps (1.66)A 6 - 13.5 amps (1.66)A**
				30 30	240 Vac 16(5)A 400 Vac 4(1)A
1NT02TL	204	400	1 cycle	240 Vac 16(5)A	
1NT08	204	400	10 10	240 Vac 16(5)A	
				400 Vac 4(1)A	
1NT09	204	400	1 cycle	240 Vac 16(5)A	
1NT11	204	400	100	30 Vdc 1A	
1NT15	204	400	10	240 Vac 16(5)A	
1NT20	204	400	100	30 Vdc 1A	

* Parenthesis indicate inductive load ratings.

** KEMA rated at these current levels at specific open/close temperatures. When applying to these electrical levels, nominal open/close temperatures must be considered to determine if the thermostat selected will operate as intended in the user's application. Please consult a Sensata Engineer for additional clarification.

Standard Temperatures, Tolerances and Differential

Automatic Reset Thermostats

Nominal Top Temperature		Min. Bottom Temperature		Differential		Standard Tolerances			
°C	°F	°C	°F	°C	°F	Open		Close	
						°C	°F	°C	°F
18 to 27	65 to 80	-33	-26	11 to 16	20 to 29	±3.0	±5.5	±4.0	±7.5
				17 to 21	30 to 38	±3.0	±5.5	±4.5	±8.5
				22 to 33	39 to 59	±3.0	±5.5	±5.5	±10.0
28 to 80 and *81 to 93	81 to 176 and 177 to 199	-33	-26	11 to 13	20 to 23	±3.0	±5.5	±4.0	±7.5
				14 to 16	24 to 29	±3.0	±5.5	±4.5	±8.5
				17 to 33	30 to 59	±3.0	±5.5	±5.0	±9.0
*94 to 121	*200 to 249	50	122	11 to 16	20 to 29	±3.5	±6.5	±4.5	±8.5
				17 to 21	30 to 38	±3.5	±6.5	±5.5	±10.0
				22 to 33	39 to 59	±3.5	±6.5	±6.5	±12.0
				34 to 55	60 to 99	±5.5	±10.0	±10.0	±20.0
122 to 149	250 to 300	50	122	14 to 21	24 to 38	±4.0	±7.5	±5.5	±10.0
				21 to 33	39 to 59	±4.0	±7.5	±8.0	±14.5
				34 to 55	60 to 99	±5.5	±10.0	±11.0	±20.0
150 to 177	301 to 399	50	122	22 to 33	39 to 59	±5.0	±9.0	±9.0	±16.5
				34 to 44	60 to 79	±5.5	±10.0	±11.0	±20.0
				45 to 55	80 to 99	±5.5	±10.0	±11.0	±20.0
178-204**	351 to 399	50	122	22 to 33*	39 to 59	±5.0	±9.0	±9.0	±16.5
				34 to 44	60 to 79	±5.5	±10.0	±10.0	±20.0
				45 to 55	80 to 99	±5.5	±10.0	±10.0	±20.0

* Not valid for Fan Devices

** Top Temp for Fan Devices cannot exceed 380°F (193°C)

Manual Reset and One-Shot Thermostats

Nominal Top Temperature		Open Tolerances	
°C	°F	°C	°F
<60	<140	±4.0	±7.5
61 TO 160	141 to 320	±5.0	±9.0
161 TO 204	321 to 399	±6.0	±11.0

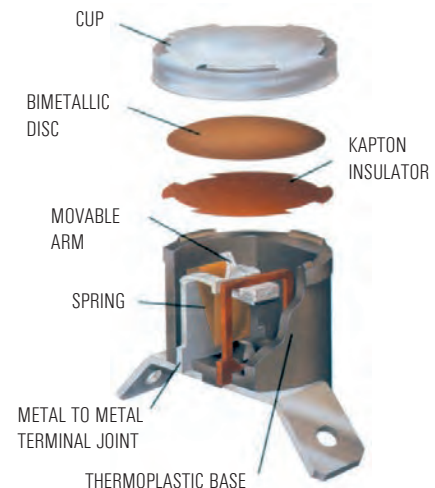

Accessories and Options Cup Styles

<p>Airstream Mount Integral Cup 57611 Material: Aluminum Available mounting rotation relative to terminals - 0° or 90° Closed Bottom Only</p>	<p>Flat Cup 73926 Materials: Aluminum, Stainless Steel or Copper</p>	<p>3NT Flange Cup 57366 Material: Aluminum or Copper Closed Bottom Only</p>	<p>Airstream Mount Integral Cup 27185 Material: Stainless Steel Available mounting rotation relative to terminals 0°, 45° or 90° with Closed Bottom 0° or 90° with Open Bottom</p> <p>Note: Available Diameter Mounting Holes with open bottom: 3.7 (.146) with closed bottom: 3.7 (.146) / 4.2 (.165) or none</p>
<p>Airstream Mount Integral Cup (slotted mounting holes) 57367 Material: Aluminum Available mounting rotation relative to terminals - 0° or 90° Closed Bottom Only</p>	<p>Wide-Eared Integral Cup 57608 Material: Stainless Steel Available mounting rotation relative to terminals - 0° or 90° Closed Bottom Only</p>	<p>"Tear-Drop" Integral Cup 57609 Material: Stainless Steel Available mounting rotation relative to terminals - 0° or 90° Closed Bottom Only</p> <p>Note: 90° mounting option is also available with 5/812 teardrop shaped stiffening flange upon customer request.</p>	<p>Large Oval Integral Cup 59122 Material: Aluminum Available mounting rotation relative to terminals - 0° or 90° with Open Bottom 0°, 45° or 90° with Closed Bottom</p>
<p>Flanges</p> <p>Fixed Rotation Surface Mount Flange 57336 Available mounting rotation relative to terminals - 90° with Aluminum - 0°, 90° / or 57°, 127°, 135° CCW with Nickel Plated Steel</p>	<p>Loose Ear Surface Mount Flange 27183 Material: Aluminum</p>	<p>Wide Eared - Fixed Rotation Mounting Flange 57337 Material: Nickel Plated Steel Available mounting rotation relative to terminals - 45° CCW</p>	<p>Bolt On Assembly 73972 Thread Specs: Metric: M4 x 0.7 - 6G M5 x 0.8 - 6G Stud Length: Metric: 6.15, 7.00, 8.00, 9.00 (with M4) 8.00 (with M5) English: 6 x 32 - 1/2" Long 8 x 32 - 1/2" Long Material: Stud: Zinc Plated Steel Cap: Aluminum</p>

All dimensions mm (in.)

Accessories and Options (cont.)

<p>Terminals</p> <p>Solder Terminal 27182* Material: Tin Plated Brass</p>	<p>Crimp Terminal 27184* Material: Tin Plated Brass</p>	<p>Quick Connects</p> <table border="1"> <thead> <tr> <th></th> <th>27132</th> <th>27162*</th> <th>27163</th> </tr> </thead> <tbody> <tr> <td>Thickness (A):</td> <td>0.8(.031)</td> <td>0.5(.020)</td> <td>0.8(.031)</td> </tr> <tr> <td>Width (B):</td> <td>6.3(.250)</td> <td>4.8(.187)</td> <td>4.8(.187)</td> </tr> </tbody> </table> <p>Materials: Brass - Solid, Ni, Ag, or Tin Plated Steel - Nickel Plated</p>		27132	27162*	27163	Thickness (A):	0.8(.031)	0.5(.020)	0.8(.031)	Width (B):	6.3(.250)	4.8(.187)	4.8(.187)
	27132	27162*	27163											
Thickness (A):	0.8(.031)	0.5(.020)	0.8(.031)											
Width (B):	6.3(.250)	4.8(.187)	4.8(.187)											
<p>Screw Terminal 57200 Material: Nickel Plated Steel M3 x 0.5 Class 6H Thread</p>	<p>Weld Terminal 57201 Material: Nickel Plated Steel</p>	<p>Weld Terminal 57312* Material: Nickel Plated Steel</p>												

*10A Max. on all terminals 0.51 (.020) thick
All dimensions mm (in.)

1NT Series Agency Listings

Type	Agency Region		
	UL/C-UL N. America	KEMA Europe	METI Japan
1NT01, 02	•	•	•
1NT08	•	•	•
1NT09, 10	•	•	•
1NT11, 12, 19, 20	•	•	•
1NT15	•	•	•
1NT01E, 02E	•	•	•
Reference Numbers	File: E9977 Category: XAPX2 XAPX8	KEMA cert # EN2014531.16	

Important Notice

Users are solely responsible for design application and function of the end use product. Users must evaluate the suitability of these devices to their application with respect to temperature settings, mechanical cycle life, electrical loading and environmental conditions. These devices are not environmentally sealed and have exposed electrical components. They are not intended for use in applications where exposure to condensed or dripping liquids, immersion in liquid, or exposure to other environmental contaminants may occur. In such cases, use of environmentally sealed devices such as the 3NT is recommended. Next to a 3NT we have a bear 1NTS (sealed) device available (see pictures page 45). Excessive mechanical cycling, high electrical loading or exposure to liquids or environmental contaminants as noted above can compromise electrical insulating properties of the device. Such conditions may result in insulation breakdown and accompanying localized electrical heating. The device may remain permanently closed or open as a result of these conditions, as well as at normal end-of-life.

Sample Order Placement

To enable Sensata Technologies to serve you in a quicker, more efficient manner, please be prepared to provide the following information when requesting samples:

1. Detailed application description
2. Estimated yearly usage.
3. Opening and closing temperatures
4. Max. temperature tolerances allowable
5. Switch type
6. Mounting style desired
7. Terminal orientation and material
8. Electrical load

Other conditions which are likely to affect the 1NT operation should also be described. These include:

1. Maximum temperature exposure
2. Location with respect to heat source
3. Temperature transfer medium (air, metal surface, etc)
4. Possible contamination sources (lint, chemical fumes, liquid, condensation, humidity, etc.)

When ordering thermocouple samples, specify whether J, K, or T type and the lead length desired. Standard wire size is 30 Ga..

Thermostat Handling Tips

1. Exposed disc devices should be kept free of dust and particulates, liquid and condensation. The face of the disc should never be snapped.
2. Mounting screws and drivers for use with smaller integral cups and flanges should be sized to provide adequate clearance to the thermostat body.
3. The installation force applied to the cup face should not exceed 66.7N (15 lbs.)
4. The maximum reset force on the manual reset and trip free button is 22.2N (5 lbs.).

1NTS (sealed)

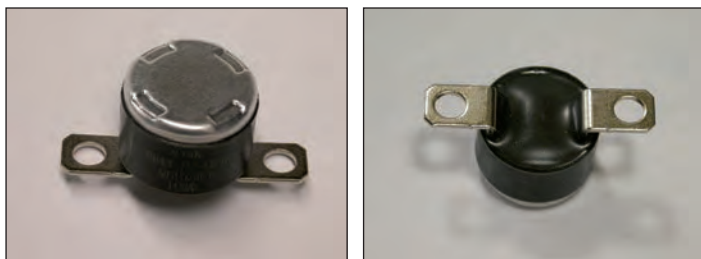

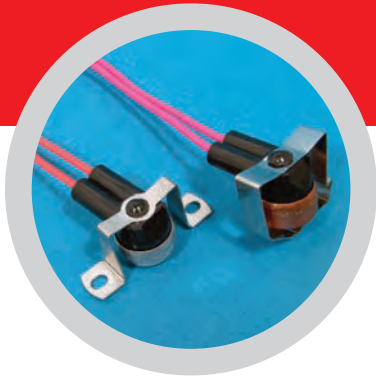

KLIXON | 3NT SERIES FIXED TEMPERATURE THERMOSTATS

WORLD CLASS PERFORMANCE

The 3NT is an automatic reset thermostat designed to meet customer specific application requirements. With its unique dry seal, the switch is protected from environmental hazards such as water, dust, oil, etc. without the use of epoxies or additives. The 3NT is UL/CSA, KEMA/ENEC approved.

Sensata Technologies has been a leading global supplier of pressure sensors & switches for over 50 years.

Key Features

- Automatic Reset
- Small and easy to mount
- Fast thermal response
- Innovative dry seal design - protects from moisture and dust
- Reliable 100K cycle life
- High temperature - to 275°F (135°C)

General Description

The 3NT thermostat from Sensata Technologies is a new, custom built, automatic reset thermostat designed to meet your specific application requirements. Its patented, tamperproof, Klixon® snapacting bimetal disc provides reliable, repeatable switch actuation, for electrical loads ranging from dry circuits to 10A @ 240Vac.

The dry seal also allows direct integration of the thermostat into a wire harness, eliminating extra connections.

The core of the 3NT is the proven 1NT thermostat. Recognized by all major worldwide agencies, hundreds of millions are used daily in a wide variety of appliance, HVAC, automotive, and specialty applications. Manufactured since 1981, the 1NT thermostat is produced at ISO 9000 certified manufacturing sites.

Applications

Small size, a variety of mounting options, and outstanding thermal response, makes the 3NT an excellent temperature control for dehumidifiers, freezers, heat pumps, ice makers, refrigerators, or any place where a fixed temperature control is required in a wet or dirty environment.

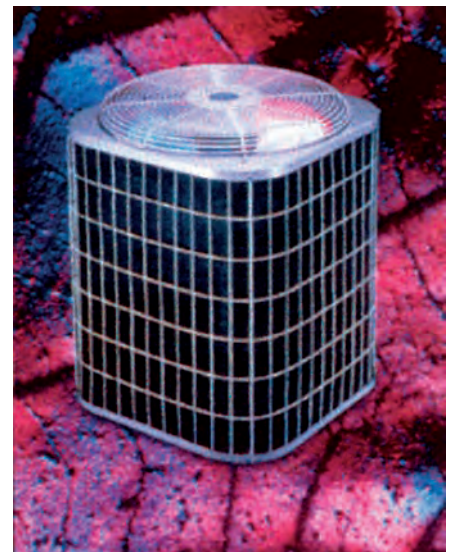

Application Shown: Residential heat pump

Design Specifications

Operating Temperature:
-20 to 135°C (-4 to 275°F)

Ambient Temperature:
-40°C to maximum wire lead insulation

Temperature rating:
PVC - 105°C
XLP - 125°C
(Allow 15°C de-rating below wire insulation rating at maximum 10A current)

Minimum Nominal Temperature Differential:
8°C (15°F)

Dielectric Strength:
750 Vrms
1500 Vrms terminals to case
Switch Configurations

Switch Configurations
3NT thermostats are SPST switches which typically reset automatically. Single operation function is available. Sensata recommends standard silver contacts for most applications. Customers may prefer to specify gold contacts for low voltage (<12V) or low current (less than 100mA) applications. Min. 25 m Amp

Standard Wire Leads:
18 AWG (1/32" or 1/16" wall thickness 105°C PVC)
16 AWG (1/32" thick, 105°C, PVC insulation) 1/32" wall thickness 125°C XLP insulation available upon request
A wide variety of wire lead terminals are available from stock. Custom termination support is available.

Agency Approvals

	File Number	Category
UL (USA) ¹	SA995	Category SDFY2
UL (CANADA) ¹	SA995	Category SDFY8
KEMA (ENEC)	2014531.16	EN 60730-2-9

1) Recognized to US and Canadian requirements by Underwriters Laboratories (UL873 and C22.2 No. 24)

Electrical Ratings

Agency	Cycles x1000	Volts	FLA	LRA	Amps (resistive)	VA
UL (USA, Canada)	100	120 Vac	5.8	34.8	10	125
	100	240 Vac	2.9	17.4	10	125
	30	120 Vac	10.0	40.0		
	30	240 Vac	10.0	40.0		
	100	30 Vdc			1	
ENEC (Europe)	30	240 Vac			16	

Standard Temperatures and Tolerances

Nominal Top Temperature		Nominal Differential		Open Temperature Tolerance		Close Temperature Tolerance	
°F	°C	°F	°C	°F	°C	°F	°C
32 to 80	0 to 27	20 - 29	11 - 16	±5.5	±3	±7.5	±4
		30 - 38	17 - 21	±5.5	±3	±8.5	±4.5
		50 - 60	22 - 33	±5.5	±3	±10	±5.5
81 to 167	28 to 75	20 - 23	11 - 13	±5.5	±3	±7.5	±4
		24 - 29	14 - 16	±5.5	±3	±8.5	±4.5
		30 - 59	17 - 33	±5.5	±3	±10	±5
*168 to 199	*76 to 93	20 - 23	11 - 13	±5.5	±3	±7.5	±4
		24 - 29	14 - 16	±5.5	±3	±8.5	±4.5
		30 - 59	17 - 33	±5.5	±3	±9	±5
*200 to 249	*94 to 121	20 - 29	11 - 16	±6.5	±3.5	±8.5	±4
		30 - 38	17 - 21	±6.5	±3.5	±10	±4.5
		39 - 59	22 - 33	±6.5	±3.5	±12	±6.5
		50 - 99	34 - 55	±10	±5.5	±20	±11
250 to 275	122 to 135	24 - 38	14 - 21	±7.5	±4	±10	±5.5
		39 - 59	22 - 33	±7.5	±4	±14.5	±8
		60 - 99	34 - 55	±10	±5.5	±20	±11

*Minimum bottom temperature of 50°C (122°F)

Numbering System

Part Number

3NT	01	L	H	XXXX
Sensata P/N Series	Contact Material	Switch Opening Logic	Dry Seal Construction	ID Number
	01 - Silver 11 - Gold	L - On Temp. Rise F - On Temp. fall	H - High Temp. (Silicon rubber) N - No leads	Customer & Application Specific

Temperature Code

L	50	F	30
Switch Type	Operating Temperature	Temp. Code	Differential
L - Limit F - Fan	Nominal Opening Temperature	C - Celsius F - Fahrenheit	Difference between Nominal Open and Nominal Close Temperature

Typical Physical Characteristics Dimensions in mm (inches)

<p>Basic 3NT Dimensions</p>	<p>Surface Mount Clip</p>	<p>Surface Mount Clip</p>
<p>Locking Tube Mount Clip (ø3/8) Shown</p> <p>Additional Clips Available for [ø1/4], [ø5/16], [ø1/2], [ø5/8] Tubes</p>	<p>Open Tube Mount Clip (ø3/8) Shown at 90° CCW Rotation 90° and 180° CW Rotations Available</p> <p>Additional Clips Available for [ø1/2], [ø5/8] Tubes</p>	<p>Snap Tube Mount Clip For (ø5/16) and (ø3/8) Tubes</p>

Ordering Samples

Sensata encourages the use of engineering test samples to assist in your thermostat specification process. Please call or FAX the following information for the fastest possible sampling lead times:

1. Customer product application
2. Electrical load requirements:
voltage, current, power factor
(inductive loads)
3. Nominal setpoint temperatures
(opening and closing)
4. Maximum allowable temperature
setpoint tolerances (see table for
standards)
5. Mounting style desired:
- flat surface - screw hole or
snap-in
- tube - diameter and orientation
6. Cup material (aluminum or copper)
7. Lead wire specifications
(length, wire gage, terminations,
insulation type and thickness)
8. Estimated annual usage

Non-functional thermocouple samples are available to determine thermostat setpoints. Please specify thermocouple type (J,K,T) and length. Standard wire size is 30 gauge.

3NT Dry Seal Design

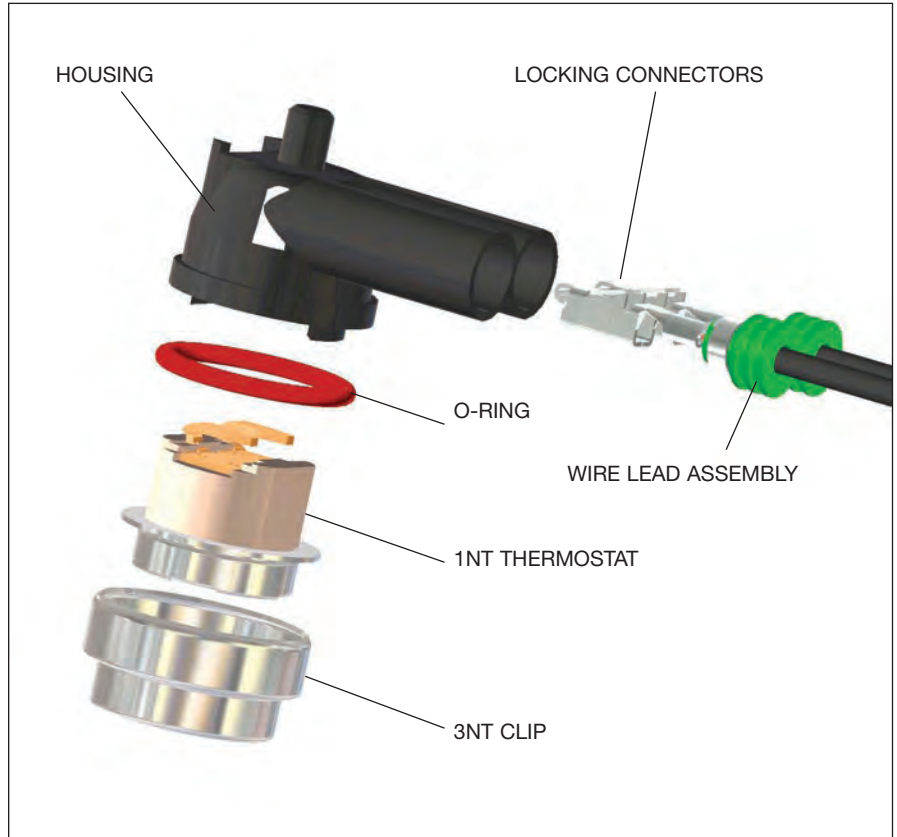

Important Notice: The 3NT is not hermetically sealed, and should not be submerged in liquid. For such applications, please contact Sensata Technologies for advice.



KLIXON | 20413, 20600, and 20650 SERIES FIXED TEMPERATURE THERMOSTATS

Snap-Action Automatic or Manual Reset

WORLD CLASS PERFORMANCE

The 20413, 20600 and 20650 series thermostats are especially designed for applications where space, capacity and ease of assembly are important production factors. They are fixed-setting, snap acting, automatic or manual reset temperature controls ideal for applications such as: AC, Heating and Ventilation equipment, dryers, unit heaters, etc.

Sensata Technologies has been a leading global supplier of pressure sensors & switches for over 50 years.

Key Features

- Klixon snap-action bimetal disc assures positive make/break action.
- Available with surface, thru-wall, well or cavity-type mountings
- Temperature setting factory calibrated to your specifications
- High capacity – up to 30 amps at 120, 240, and 277 VAC resistive.
- Extra high capacity – up to 40 amps at 120 and 240 VAC resistive

Description

All automatic series are available as limit switches (open on temperature rise) or fan switches (close on temperature rise). Switch action is SPST, SPDT, or DPST with automatic reset types. Manual reset is available as a limit switch in SPST construction only.

The switch mechanism is actuated by the Klixon snap-action, bimetal disc which may be enclosed or exposed. Enclosed disc devices are particularly recommended for applications in which dust and lint are prevalent in the environment. Exposed disc types are used in applications where a faster thermal response to radiant heat is needed. Contact parts are enclosed for both disc types for protection against contamination.

Mountings and Terminals

A variety of terminals and mounting flanges are available to meet installation requirements of most applications. Flanges can be used for surface or thru-wall mountings; or, thermostats can be supplied without flanges for well or cavity-type mountings. Flange rotations are specified by looking down on the terminals and rotating the flange 30°, 45°, or 90° CW or CCW.

Flanges Available

- Small oval bottom flange
- Integral surface flange
- No flange cup
- 3/4" deep cup
- Special oval bottom flange

Electrical connections to the thermostat must be tight; otherwise, resistance in a loose connection may cause sufficient temperature rise to affect the performance of the thermostat or damage the terminals or the lead wire insulation.

Terminals Available

Quick connects are available in brass, tin plated, or plain brass.

- 1/4" Quick connects 0°, 30°, 45°, 90° terminals are male spade type .250" x .032" thick.
- Brass screw terminals 0°, 45°
When screw terminals are specified, washer head screws are supplied unassembled. Assembled washer head screws are available at extra cost. Standard screw terminals have 8-32 NC-2 threads.

Temperature Settings, Tolerances and Nominal Differentials

The ranges of temperature settings, tolerances, and nominal differentials

shown below are available. Differential is the difference between opening and closing temperature in °F. For example, a thermostat which opens at 180°F and closes at 140°F has a 40° differential. (Lowest unit prices are achieved by selecting differentials in the 30°F to 59°F range). For temperature settings and differentials other than those shown, please consult Marketing.

Manual Reset Constructions

There are two basic manual reset constructions:

- 1) Manual Override – contacts can be closed at any time after device has actuated by depressing reset button.
- 2) Trip-Free – contacts will remain open after device has actuated until bimetal disc resets, even if reset button is depressed.

Standard Tolerances

Highest Temperature Setting °F	Nominal Differential °F	Standard Tolerances	
		Open °F	Close °F
-10 to 80	10 to 14*	±5	±5
	15 to 29	±6	±6
	30 to 59	±6	±7
	60 to 150	±7	±8
81 to 200	10 to 29*	±5	±5
	30 to 39	±5	±6
	40 to 59	±5	±7
	60 to 150	±6	±8
201 to 250	20 to 29	±5	±6
	30 to 39	±5	±7
	40 to 59	±6	±8
	60 to 150	±7	±9
251 to 300	30 to 39	±6	±8
	40 to 59	±7	±10
	60 to 150	±8	±11
301 to 350 **	30 to 39	±7	±10
	40 to 59	±8	±12
	60 to 150	±9	±13

Agency Recognition

Klixon 206 Series Thermostats are recognized by UL and CSA. Please consult Marketing for international approvals.

UL Electrical Group
File No. E9977
U.S. Guide No. XAPX2
Canada Guide NO. XAPX8
HC&R Group
File NO. MP986
U.S. Guide No. MBPR2
Canada Guide No. MBRR8

- Available in SPST construction only. SPDT thermostats must have 15° minimum differentials.
- **20413 series – up to 300°
- 20600 series – up to 350°
- 20650 / 54 series – up to 300°; minimum differential 30°.

Automatic Reset Standard Constructions



Manual Reset Standard Constructions



Underwriters' Laboratories Electrical Current Ratings

Device	Contacts	Number Cycles	120 V				240 V				277 V				480 V				800 mV DC
			Amps Res	FLA	LRA	Pilot Duty	Amps Res	FLA	LRA	Pilot Duty	Amps Res	FLA	LRA	Pilot Duty	Amps Res	FLA	LRA	Pilot Duty	
20413 MR	1-3	6,000	48	16	96	480	48	8.3	48	690					48			690	
20613	1-3	6,000	48	16	96	480	48	25	48	690					48			690	
20600D	1-2	100,000	10	5.8	34.8	125	5	25	17.4	125									
	1-3	30,000	25	16	84	672	25	25	60	960	22	8	42	775					
	1-2	30,000	10	5.8	34.8	270	5	25	17.4	270	5			125					
20601F, L	1-3	100,000	25	10	60	480	25	25	30	480									
(appliance)	1-3	30,000	25	16	84	672	25	23	60	960	22	8	42	775	13	5	30		
20601 (HVAC)	1-3	100,000	16.6	16.6	88	480	8.3	5	49.8	690	7.2	7.2	43.2	1630					
20602F or L	1-3	100,000				125													X
20603/5	1-3	100,000	40	35	110	880	40	35	110	1760	35	30	95	1760	20	9	30	960	
20604F, L	1-3	100,000	25	10	60	480	25	5	30	380	22	8	42	775	13	5	10	320	
20606F, L	1-3	100,000				125													
20611L MR	1-3	6,000	25	10	60	480	25	5	30	480									
20612 MTR	1-3	6,000				125													X
20616 MR	1-3	6,000				125													
20615L MRTF	1-3	6,000	16.6	10	60	480	8.3	5	30	480	7.2			690					
20619L MRTF	1-3	6,000	25	10	60	480	25	5	30	480	25			690					
20650F, L	1-3, 4-5	100,000	25	10	60	480	25	5	30	480	22	8	42	775					
20650F, L, H	1-3	30,000	25	10	60	480	25	5	30	480	23	23	100	1855	13	5	30	400	
	4-5	30,000	25	16	84	672	25	12	60	960	23	23	88	1633					
20650H	1-3	6,000					25	7	42	670									
	4-5	6,000					23	7	42	670									
	5-2	6,000					5	5.8	39.8	556									

Standard Configurations

Model	Switch Type	Capacity	Contacts	Clearance	
				Thru Air	Over Surface
20413L	MR-TF	High	Ag	3/8"	1/2"
20600D	SPDT	High	Ag	1/8"	1/4"
20601L, F	SPST	High	Ag	1/8"	1/4"
20602L, F	SPST	mVdc	Au	1/8"	1/4"
20603L, F	SPST	Extra High	AgCdO	1/8"	1/4"
20604L, F	SPST	High	Ag	1/4"	3/8"
20605L, F	SPST	Extra High	AgCdO	1/4"	3/8"
20606L, F	SPST	Pilot Duty	Ag Ribbed	1/8"	1/4"
20611L	MR	High	Ag	1/8"	1/4"
20612L	MR	mVdc	Au	1/8"	1/4"
20615L	MR-TF	High	Ag	1/8"	1/4"
20616L	MR	Pilot Duty	Ag Ribbed	1/8"	1/4"
20619L	MR-TF	High	Ag	1/4"	3/8"
20650L, F	DPST	High	Ag	1/8"	1/4"

SMALL APPLIANCES INDUSTRIAL & LIGHTING

20413 Series Standard Constructions

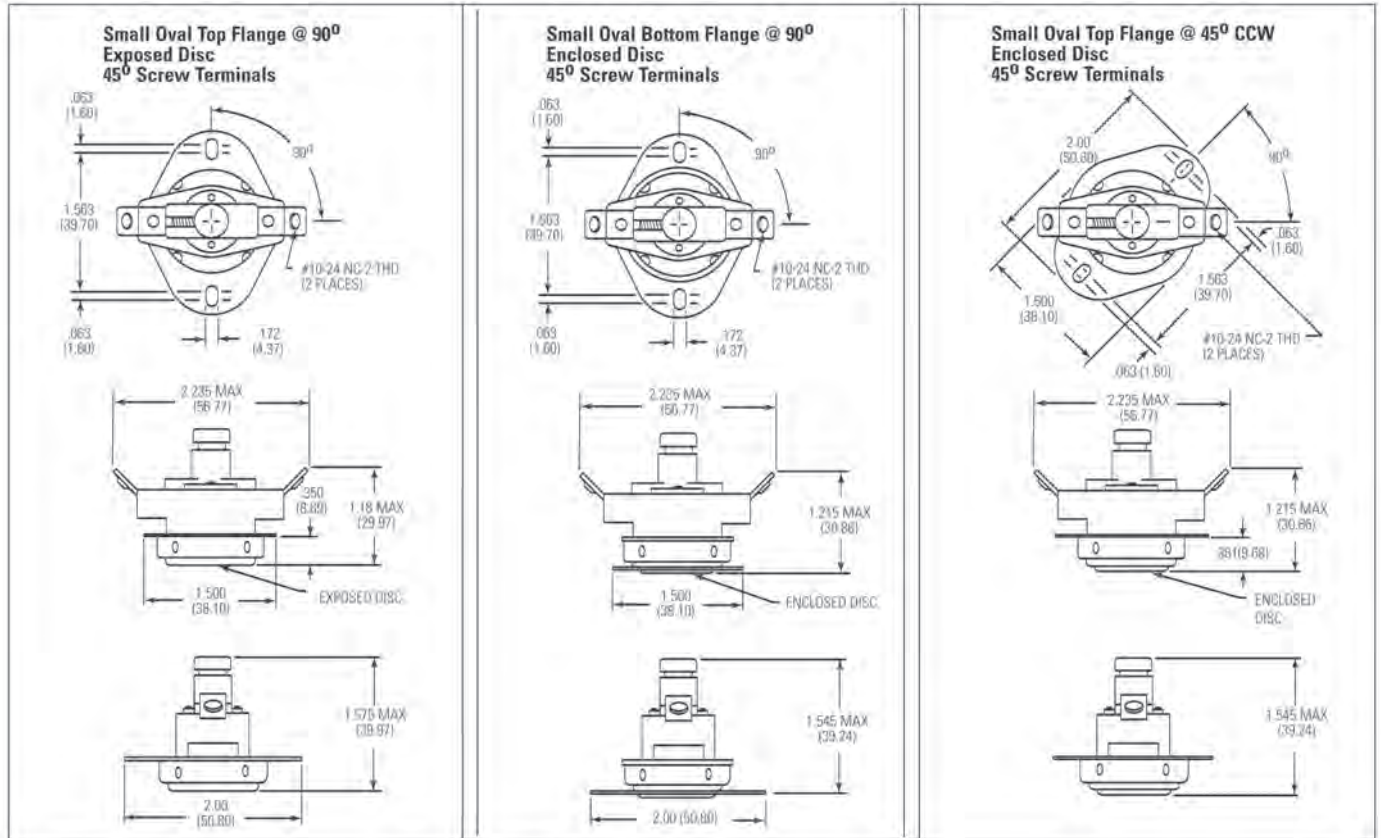

20650 Series Standard Constructions

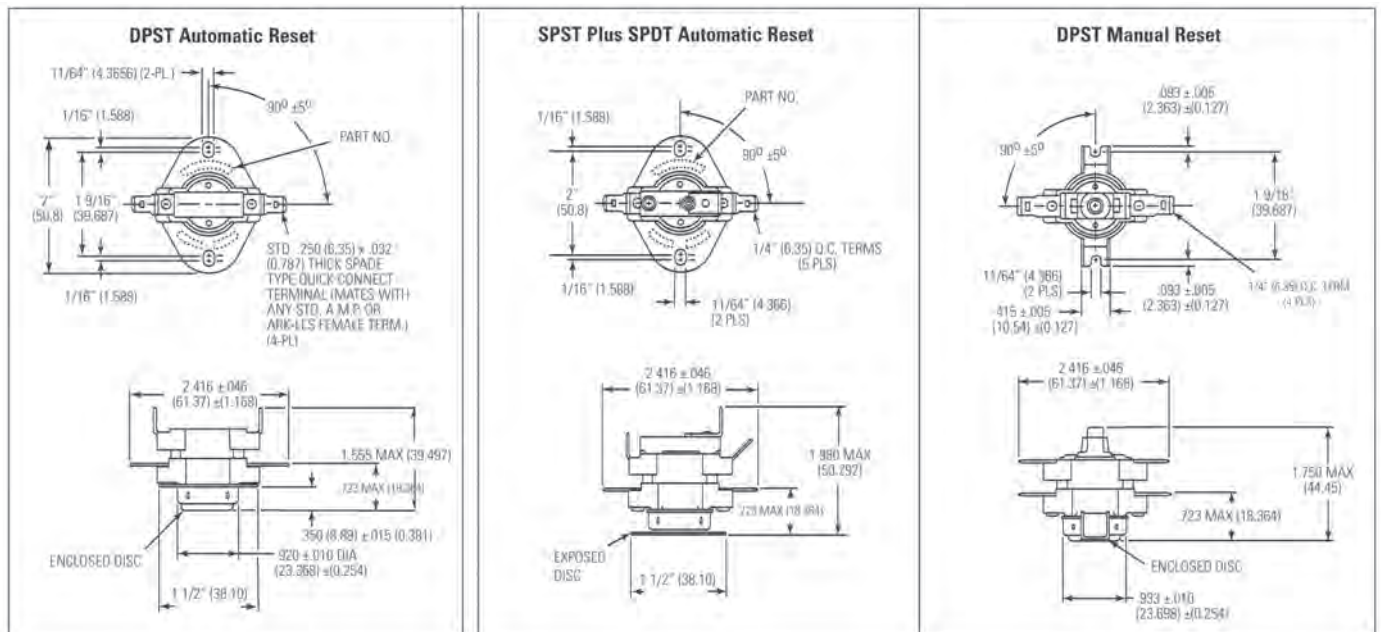

20600 Series Preferred Physical Constructions

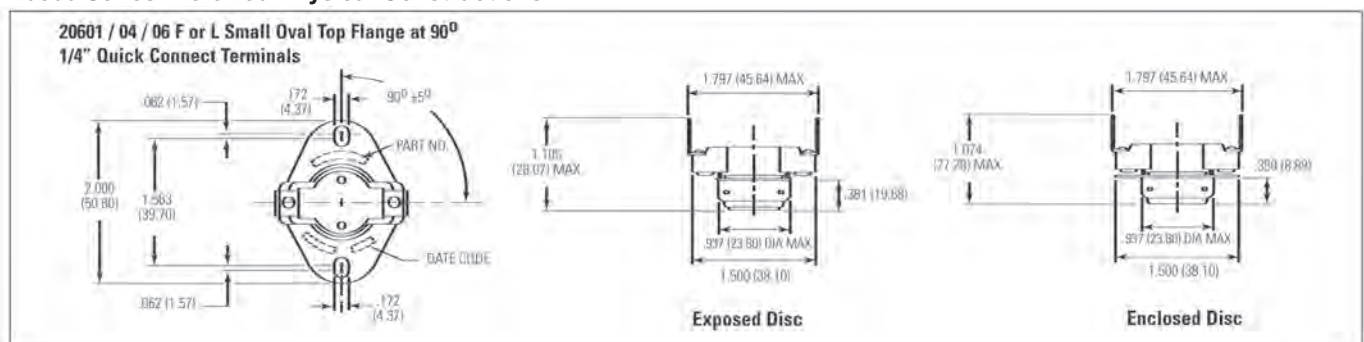

Other Physical Constructions

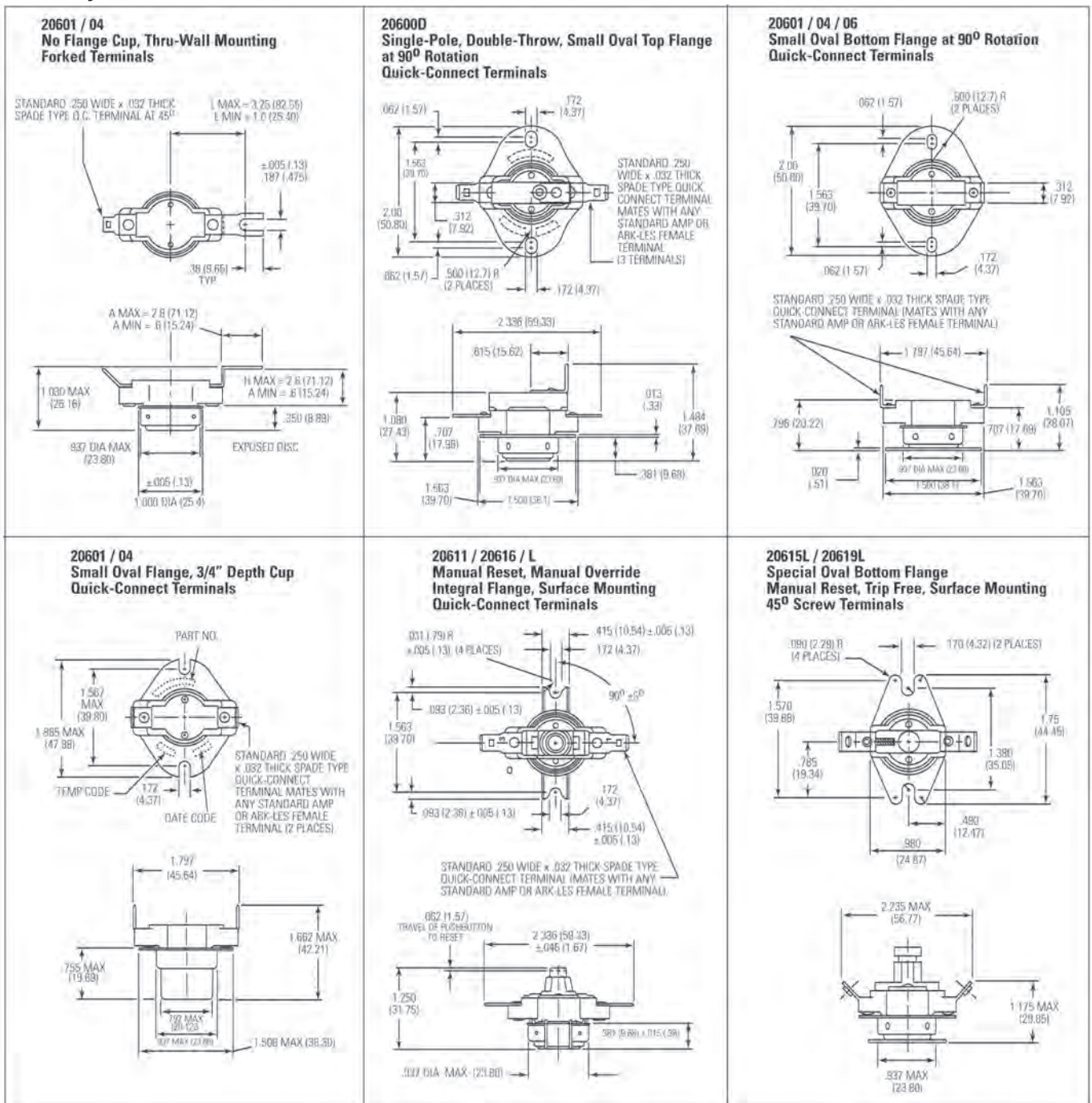



KLIXON | 20425 SERIES HIGH **CURRENT DEFROST THERMOSTATS** *20425 Series, Snap-Action Automatic Reset*

WORLD CLASS PERFORMANCE

Klixon® 20425 Series thermostats are fixed setting, low-cost snap-action temperature controls designed with sealed construction for refrigeration, air conditioning and heat pump applications.

Sensata Technologies has been a leading global supplier of pressure sensors & switches for over 50 years.

The 20425 Series is available in single-pole, single-throw (SPST) or single-pole, double-throw (SPDT) automatic reset configurations. All operating parts and lead connections are contained within a metal cup which is filled with an epoxy resin compound to completely seal out moisture, dust and other contamination. Temperature actuation is initiated by the

Klixon snap-action bi-metallic disc. The snap-action of the disc provides fast, accurate switching. The disc is located at the bottom of the cup where thermal change at the mounting point is quickly transmitted to give this product a high degree of thermal sensitivity. A variety of mountings are available, as shown on page 61.



Features & Benefits

- Completely sealed thermostat.
- Resists shock and vibration regardless of mounting position - Klixon® snap-action thermal disc assures positive make/break action.
- Splash proof enclosure - sealed against dirt and moisture.
- Easy to mount - available with bottom,



- thru-wall or tube mounting
- High capacity - up to 25 amp, 120 and 240 VAC resistive. UL recognized for 100,000 cycles. (SA995)
- Tamperproof - temperatures are factory set.
- Automatic reset - recycles automatically.

Temperature Settings, Tolerances and Nominal Differentials

The list of temperature settings, tolerances and nominal differentials shown below are standard. (Selection of larger differentials and wider tolerances offer the lowest unit price). If settings and differentials other than those shown are desired, please contact Sensata Marketing.

Range of Temperature Settings		Mfg.* Tolerances		Minimum Mean Temperature Differential
		Open	Close	
(-10) 81	80	±6	±6	15°F
	221	±5	±5	15°F
(-10) 81	80	±6	±6	20°F
	221	±5	±5	20°F
(-10) 81	80	±6	±7	30°F
	221	±5	±5	30°F
(-10) 81	80	±6	±7	40°F
	221	±5	±7	40°F

* Customers checking tolerances should allow for differences in test equipment.

Ambient Temperature Exposure (Maximum)

20425 Series.....0°F to 221°F
 20427 Series.....0°F to 221°F
 20428 Series.....0°F to 221°F

Contact Description

Klixon 204 Series thermostats are supplied in two contact structures identified by the numbers following the basic series number.

The letter “F” added to the series number indicates that the thermostat is supplied as a fan switch (closes on temperature rise). The letter “L” indicates that the thermostat is supplied as a controlling and high limit control (opens on temperature rise).

All thermostats with “F” and “L” designations are supplied with single-pole, single-throw switching action while “D” indicates single-pole, double-throw switching action.

Leads

Leads are attached to the terminals of the basic unit prior to sealing. Leads are #14, #16, or #18 gauge wire size, and are provided with ends stripped. Quick connect terminals, eyelets, or other terminal configurations are available at additional cost.

Length of lead as required by customers is measured from the center of the thermostat to:

1. End of stripped wire
2. Center of eyelet
3. Center of right angle Quick Connect
4. End of straight Quick Connect Standard Polyvinyl Chloride (PVC) insulation is available in a variety of colors as required. XLP wire insulation is available as an option.

Electrical Ratings - UL and CSA Recognized

	TERMINALS 1 & 3, 14 or 16 AWG WIRE SPST				TERMINALS 1 & 2, 14 or 16 AWG WIRE SPDT			
	100,000 Cycles							
	VDC	VAC			VDC	VAC		
		120	240	277		120	240	277
RES		25	25	15		10	5	
FLA		13	13			5.8	2.9	
LRA		60	60			34.8	17.4	
VA		125	125			125	125	

	30,000 Cycles							
	VDC	VAC			VDC	VAC		
		120	240	277		120	240	277
RES		16	16			5	2.5	
FLA		16	16	15				
LRA		65	65	60				
VA		125	125	125		125	125	

	6,000 Cycles							
	VDC	VAC			VDC	VAC		
	12	120	240	277	12	120	240	277
RES	1	16	16	10	1	15	15	10
FLA		16	16	10				10
LRA		65	65	45				45
VA		125	125					

*Note: FLA rating 7A with 18AWG wire

RES Resistive Amps
 FLA Full Load Amps
 LRA Locked Rotor Amps
 VA Volt Amp, Pilot Duty

UL File No. SA995
 Guide No. SDFY2
 Guide SDFY8 for category

Wire Size (AWG)	20425 Series
#14 5/16th wall	105°C PVC, UL approved 1060 appliance wire
#16 1/16th wall	UL Style 1056
#16 1/32nd wall	UL Style 1015
#18 1/16th wall	UL Style 1056
#18 1/32nd wall*	UL Style 1015

Engineering Services

Sensata field sales engineers who understand your temperature control problems and how our products solve them are available to discuss your application needs. Use their expertise to eliminate needless engineering cost and give your products a competitive edge.

How to Order Samples

When requesting samples, faster service is possible when your application is described in detail. A description of the duty cycles of the thermostat should be included.

Please Specify:

1. Load requirements (inductive or resistive).
2. Temperature settings (opening and closing).
3. Maximum tolerances allowable on temperature settings.
4. Lead wire specifications (length, wire size, type termination).
5. Type mounting flange.
6. Estimated yearly usage.

Other conditions which affect the thermostat should be described:

1. Maximum and minimum temperature exposure.

Electrical Clearances

1/4" through air to ground
 3/8" oversurface to ground

SMALL APPLIANCES INDUSTRIAL & LIGHTING

2. Location with respect to heat source.
3. Temperature transfer medium (air, metal surface, etc.).
4. Possible contamination sources (lint, chemical fumes, etc.).
5. Exposure to liquid and submersion.

Dimensional Drawings

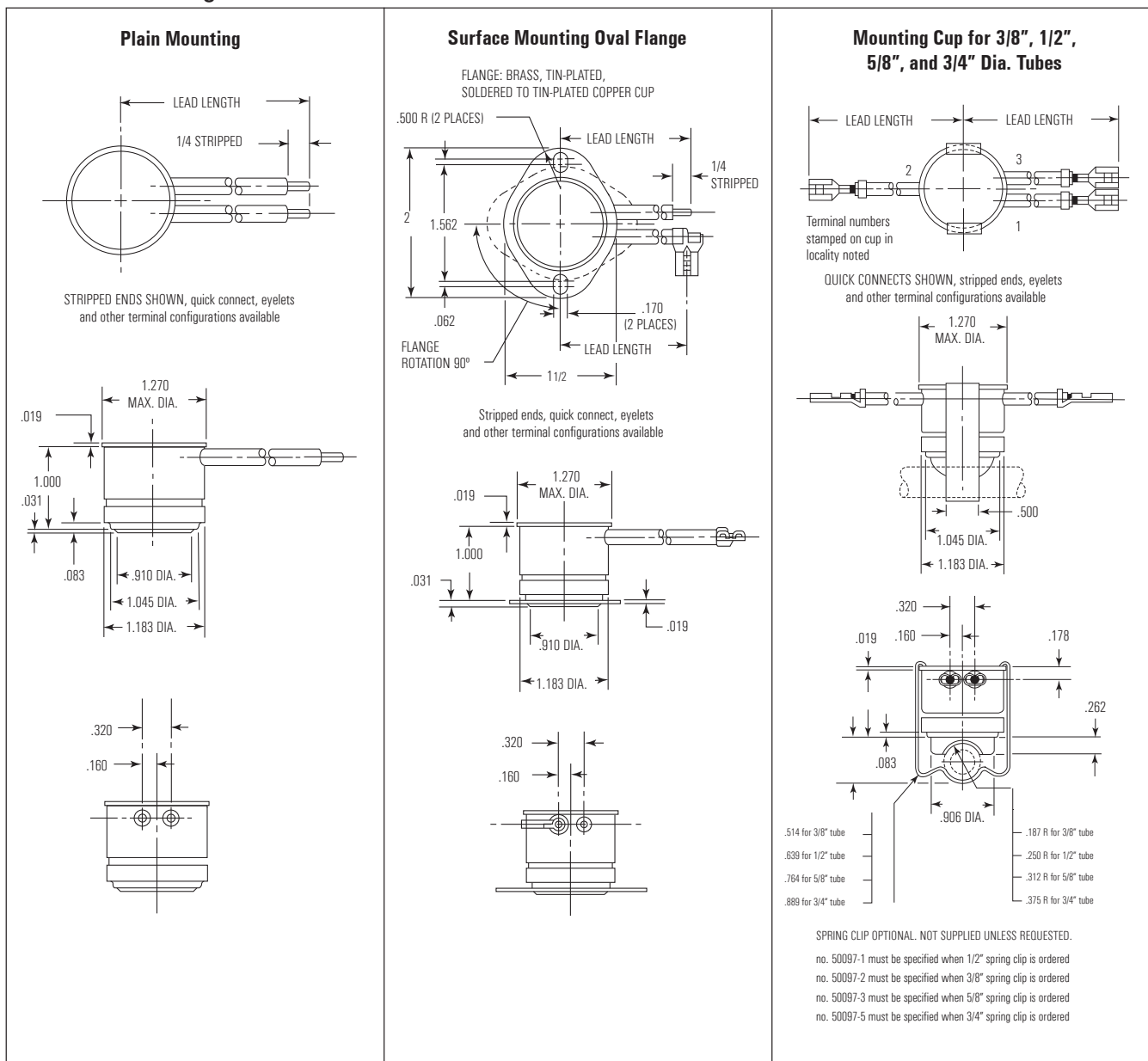

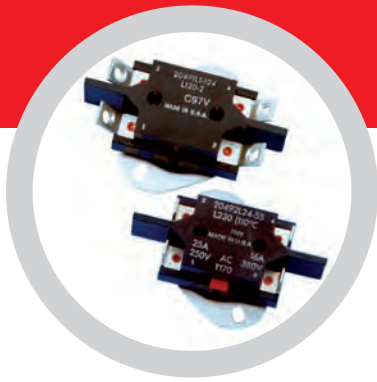

KLIXON | FIXED TEMPERATURE THERMOSTATS

20490 and 20491 Series, Double Pole Automatic Reset
20492 and 20493 Series, Double Pole Manual Reset

AUTOMATIC RESET 20490 and 20491 Series

The high capacity automatic series are available as limit (L) switches which open on temperature rise and fan (F) switches which close on temperature rise.

MANUAL RESET 20492 and 20493 Series

The high contact capacity eliminates the need for costly back-up contacts and low capacity manual reset limit controls in electric heat applications.

Sensata Technologies has been a leading global supplier of sensors & switches for over 50 years.

Features

- Double Pole Single Throw (DPST)
- Manual Reset/Trip free
- Automatic Reset
- Heavy Duty Capacity - up to 48 amperes per pole
- Snap-Action resists shock and vibration regardless of mounting position
- Tamperproof - temperatures are factory set to customer requirements
- Molded Phenolic Case - seals out lint, dust, and other contamination
- Compact - easily mounted where space is limited
- High Reliability

Automatic Reset

The Klixon 20490 and 20491 series are especially designed for the electric heat, laundry, and other major appliance markets. The high capacity automatic series, (20490 and 20491) are available as limit (L) switches, which open on temperature rise, and fan (F) switches, which close on temperature rise.

The switch is enclosed within a phenolic housing and stainless steel cup assembly which protects the contacts from contamination. The stainless steel cup also provides a variety of mounting configurations.

The switch mechanism is actuated by the Klixon snap-action bimetal disc which may be enclosed or exposed. Enclosed disc types should be used in all applications where response to radiant heat is not critical as it provides protection (to the bimetal element and switch assembly) against contamination and damage due to handling. Exposed disc types are used in applica-

tions where a faster thermal response to radiant heat is required.

Standardized mounting-hole dimensions allow interchangeability with our present 204 and 206 series thermostats. The 20490 is available with the following terminal configurations: 0.250" X 0.032" flat, 45°, and 90° male quick connect; 0.187" X 0.032" 90° male quick connect; flat and 45° #8-32NC screw terminals. Only 45° #10-24 screw terminals are available on the 20491.

Temperature Setting (°F)

TEMP. RANGE	TOLERANCE		NOMINAL TEMP DIFFERENCE
	OPEN	CLOSE	
0 to 80	±6	±7	20 to 60
81 to 200	±5	±7	20 to 60
201 to 250	±6	±8	20 to 60
251 to 300	±7	±10	30 to 60

Electrical Clearances

TYPE	THROUGH AIR	OVER SURFACE
20490	1/4"	3/8"
20491	3/8"	1/2"

Manual Reset

The Klixon 20492 and 20493 series are especially designed for the electric heat and water heater markets. The high capacity eliminates the need for costly backup contacts and low capacity manual reset limit controls in electric heat applications. The contacts are enclosed for protection from contamination.

The 20492 and 20493 are designed for trip free operation. The trip free construction will not allow the contacts to be closed until the temperature of the disc is lowered to its reset point.

SMALL APPLIANCES INDUSTRIAL & LIGHTING

The 20492 is available with the following terminal configurations: 0.250" X 0.032" flat, 45°, and 90° male quick connect; 0.187" X 0.032" 90° quick connect; flat and 45° #8-32NC screw terminals. Only 45° #10-24 screw terminals are available on the 20493.

Temperature Setting (°F)

OPENING TEMP. RANGE	TOLERANCE
100 to 200	±5
201 to 250	±6
251 to 300	±7

Electrical Clearances

TYPE	THROUGH AIR	OVER SURFACE
20492	3/8"	1/2"
20493	3/8"	1/2"

Electrical Ratings - Auto Reset

100,000 cycles/pole)

20490*

Resistive	25 amperes at 240 VAC
Motor Load	10 FLA-60 LRA at 120 VAC 5 FLA-30 LRA at 240 VAC
Pilot Duty	125 volt-amperes at 120 VAC

20491*

Resistive	25 amperes at 600 VAC
Motor Load	4 FLA-8 LRA at 480 VAC
Pilot Duty	690 volt-amperes at 240 VAC to 480 VAC

*UL Recognized component for USA and Canada
File MP986
U.S. Category MBPR2
Canada Category MBPR8

Electrical Ratings - Manual Reset

(6,000 cycles/pole)

20492*

Resistive	25 amperes at 600 VAC
Motor Load	10 FLA-60 LRA at 120 VAC 5 FLA-30 LRA at 240 VAC
Pilot Duty	690 volt-amperes at 240/600 VAC 480 volt-amperes at 120 VAC

20493*

Resistive	48 amperes at 600 VAC
Motor Load	16 FLA-96 LRA at 120 VAC 8 FLA-48 LRA at 240 VAC
Pilot Duty	690 volt-amperes at 240/600 VAC 480 volt-amperes at 120 VAC

A Sensata sales representative, who knows your temperature control problems and how our products solve them, is located close at hand. Use his or her services to eliminate needless engineering cost and give your products a competitive edge.

(All dimensions are in inches unless otherwise noted.)

20490 and 20491

Standard 0.250 wide X 0.032 thick spade type quick connect terminals mate with any standard amp or ark-les female terminal

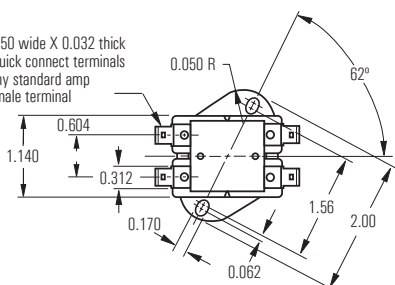

**Double Pole, Single Throw
Small Oval Flange
Top Mounting
Quick Connect Terminal**

20492 and 20493

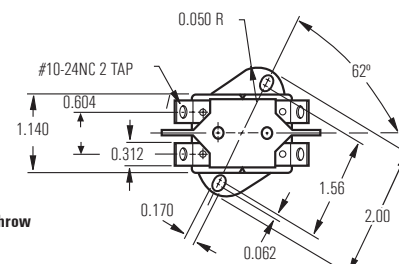

**Double Pole, Single Throw
Manual Reset
Small Oval Flange
Top Mounting
Screw Type terminals**



KLIXON | 204 SERIES FIXED TEMPERATURE THERMOSTATS

Snap-Action Automatic or Manual Reset

KEY BENEFITS

The 204 Thermostat can be mounted in any position

Construction is varied to suit specific needs

The Klixon snap-action bimetal thermal disc may be enclosed or exposed

Klixon® 204 Series Thermostats are fixed-setting, snap-action temperature limiting/fan controls used in appliances, heating equipment, and industrial or commercial apparatus. Automatic reset devices are available in single-pole, singlethrow (SPST) or single-pole, doublethrow (SPDT) configurations. Manual reset devices are available in SPST only.

The Klixon snap-action bimetal thermal disc may be enclosed or exposed. Exposed types have a faster thermal response.

Contact Description

The 204 Series Thermostats are supplied in three basic contact constructions, as identified below:

The letter “F” added to the series number, i.e, 20400F, indicates that the thermostat is supplied as a fan switch for applications such as forced air heating systems, where normally open contacts are required to close on temperature rise. The letter “L” indicates that the thermostat is applied as a limit control or a high limit safety, with normally closed contacts that open on temperature rise. The letter “D” indicates SPDT switching action, which combines the “F” and “L” functions.

Mountings

The 204 Thermostat can be mounted in any position -- in casting wells, through openings in metal enclosures, or in open space for control of air temperature.

A 204 thermostat with a “bottom flange” is used for surface mounting applications. A “top flange” is used for air-stream or thruhole mounting requirements.

Terminals

Quick connect terminals are standard 0.250” x 0.032” thick, spade type (mates with any standard female terminal).

When screw-type terminals are used, washer head screws are supplied unassembled. Assembled washer head screws are available at a slight extra cost. Terminals have #8-32 NC-2 threads.

Construction is varied to suit specific needs; therefore, be sure to specify the actual electrical loading and expected maximum and minimum temperatures when submitting application data.

Temperature Features

The 20400 series devices are operational from -10°F to 350°F, with a temperature differential of 30°F to 40°F recommended. Differential is defined as the difference between nominal open and close temperatures. A minimum differential of 10°F is required for SPST types. SPDT types require a minimal differential of 15°F.

Engineering Service

A Sensata Field Sales Engineer who can assist you with your temperature control application is as close as your telephone. They can help you eliminate needless engineering costs and give your products the competitive edge.

Configurations

- 20400 - Standard
- 20410 - Manual reset

SMALL APPLIANCES INDUSTRIAL & LIGHTING

How to Order Samples

When requesting samples, please specify the following:

1. Load requirements (inductive or resistive)
2. Temperature settings and ambient temperature exposure
3. Maximum tolerances allowable on temperature settings
4. Type terminals and mounting flange
5. estimated annual usage
6. Location with respect to heat source
7. Contamination (lint, chemical fumes, etc.)

Underwriters' Laboratories Electrical Current Ratings*

Device	Contacts	Number Cycles	120V				240V			
			Amps Res	FLA	LRA	Pilot Duty**	Amps Res	FLA	LRA	Pilot Duty**
20400D	1-2	100,000	10	5.8	34.8	125	5	2.9	17.4	125
20400D, L, or F	1-3	100,000	25	13	60	480	25	10	45	720
20410L	1-3	6,000	25	13	60	125	25	10	45	120

*Klixon 204 Series Thermostats are approved by Underwriters' Laboratories and Canadian Standards Association in accordance with these electrical ratings.

**Power factor to exceed 35%. Inrush current up to 10 times steady rate.

	File	Guide
UL	MP986	MBPR2
	E9977	XAPX2
CSA	LR21794	400-E-0

Standard Constructions

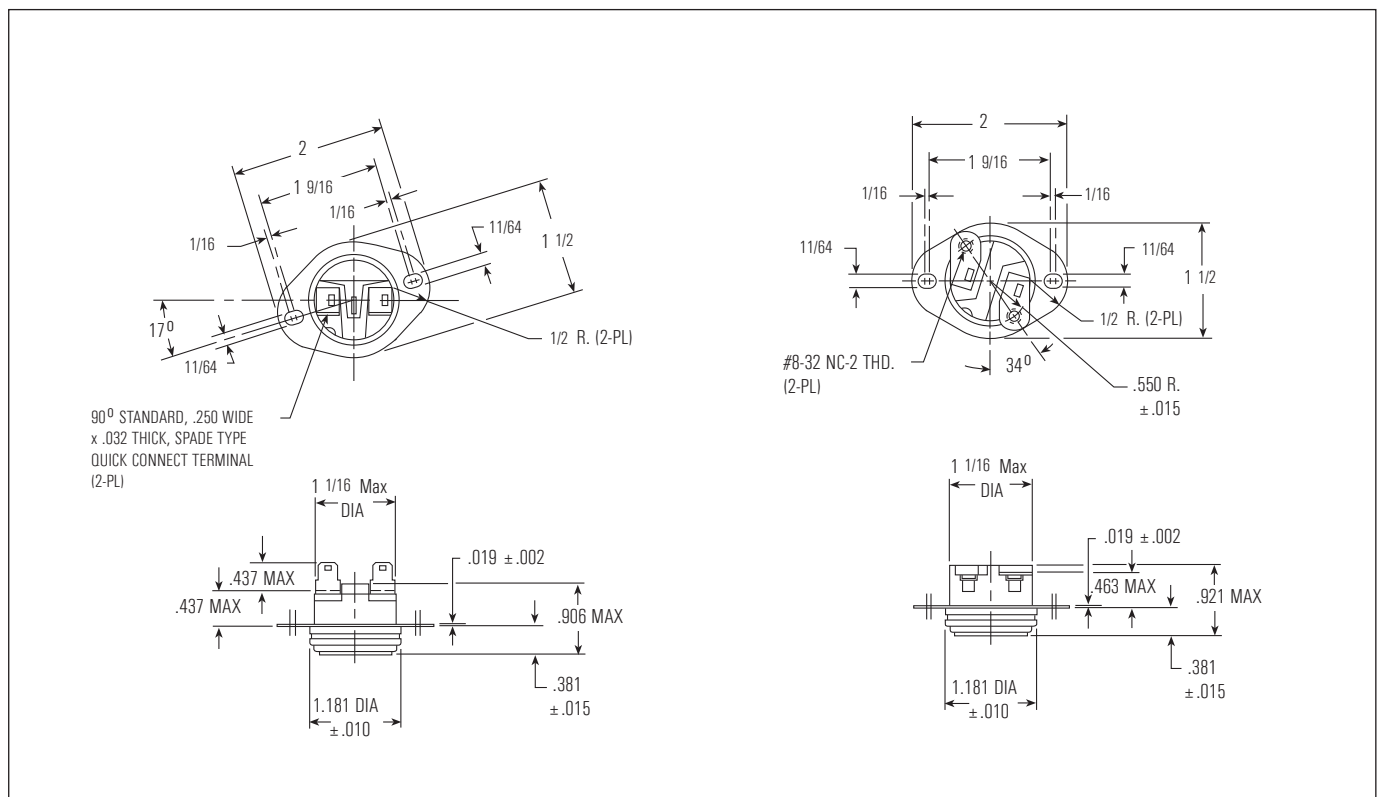



KLIXON® | 2AM/3AM/4AM/8AM MOTOR PROTECTORS

KEY BENEFITS

Available in a range of temperature and current sensitivities, the 2AM is suitable for a wide variety of applications

Compact, easy to install

Proven products backed by the leading innovators in protection technology.

Klixon® automatic motor protectors (AM series) are small, light weight and sensitive to temperature and current. The sealed steel cases will stand most dip and bake processes and can be mounted directly on motor windings for fast detection of temperature changes.

Operation

These on-winding motor protectors feature the Klixon® snapaction bimetallic disc in a normally closed circuit. The disc is actuated by the current passing thru it and the heat conducted from the motor windings. When the temperature reaches a predetermined calibration point corresponding to the maximum specified limit of the windings, the disc snaps open and interrupts the circuit. This permits maximum output while limiting the windings to a specified operating temperature. After the windings have cooled to the normal operating limit, the device resets automatically.

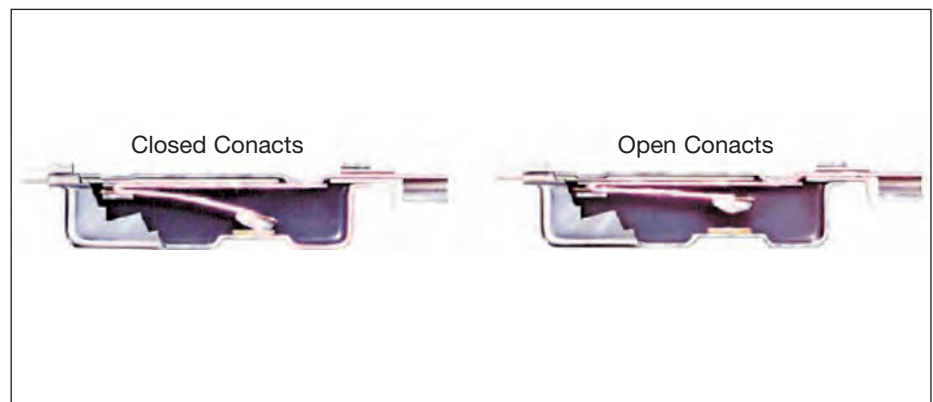

2AM/3AM/4AM wide application range

Available in a range of temperature and current sensitivities, the 2AM is suitable for a wide variety of applications. Designed to be mounted on the windings of electric motors and transformers, the 2AM protects against overheating and electrical overloading, offering the highest standards of safety and long term reliability.

Robust sealed construction

The 2AM's steel case is epoxy sealed and then insulated with a Mylar® sleeve allowing direct mounting on the windings. Robust construction and ability to withstand typical mechanical pressures make the 2AM ideal for installation during the manufacture of electric motors and transformers. Where necessary, additional sealing can be provided to prevent epoxy ingress with specialized impregnation processes.

Flexibility

By adding a customized 3rd lead, the standard device becomes a dual circuit 4AM,

SMALL APPLIANCES INDUSTRIAL & LIGHTING

ideal protection for dual voltage or dual speed applications. For higher horse power applications, the 3AM provides protection for fault conditions up to 60 Amps. With a range of anticipating heaters matching protector to motor from 6 to 60 Amps and operating temperatures from 90 to 150°C, the 2AM series provides unsurpassed

design flexibility for motor and transformer applications.

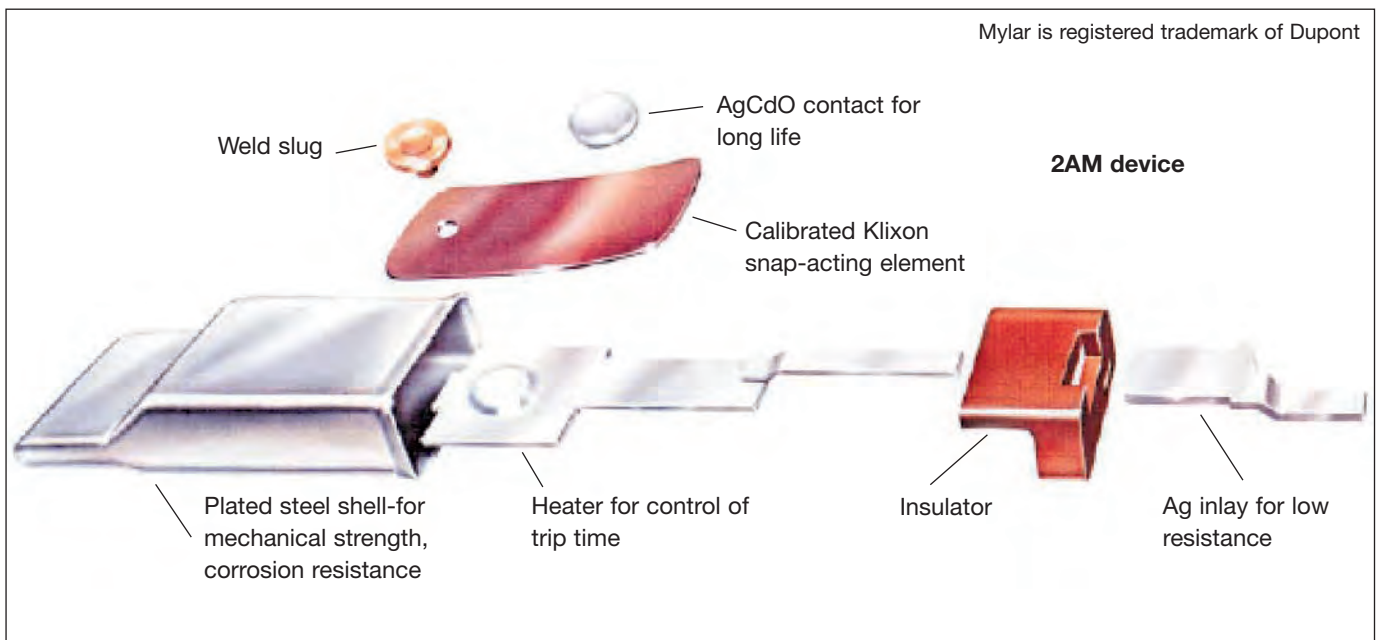

2AM 7 B S H 0500 - 140

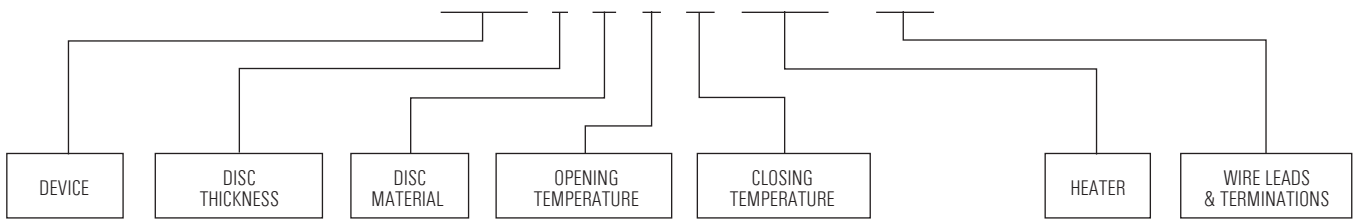

8AM 2 G V H A 10 - 120

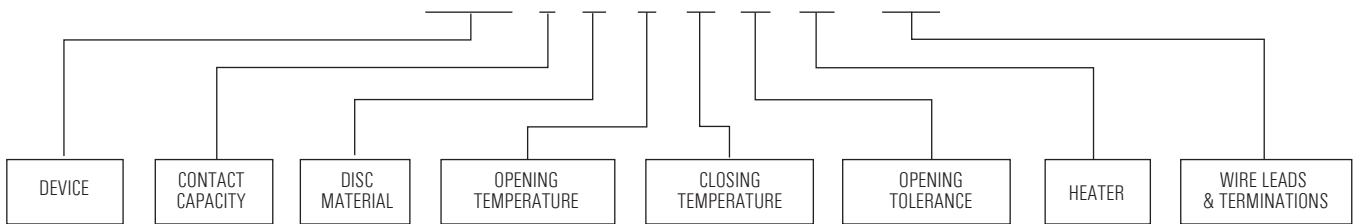

2AM Dimensions

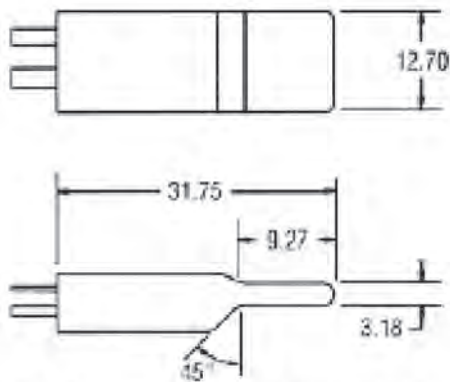

CONVERSION CHART	
INCHES	MM
.052	1.32
.125	3.18
.270	6.86
.295	7.49
.302	7.67
.365	9.27
.500	12.70
.523	13.28
.631	16.03
.965	24.54
1.060	26.92
1.250	31.75
1.390	35.31

8AM Dimensions

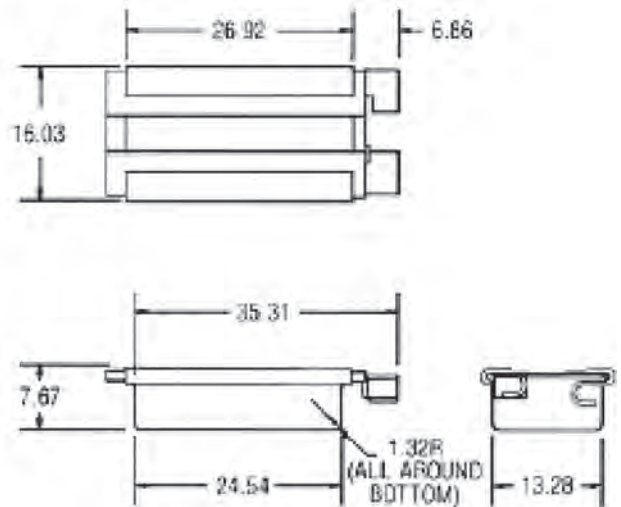

NOTE: Nominal dimensions for reference purposes only (all in inches)

Certifications

	115V	230V	UL	CSA		ENEC
2AM	50	37	standard 547	File LR23241C		standard EN60730-2-2
3AM	60	45	Guide No. 400-H13-C	Guide No. 184-N-13.90		File 2014531-19
4AM	50	37	File E15962	Class 3211		
8AM1	50		USR standard UL2111		CNR standard C22.2 No 77	standard EN60730-2-2 File 2014531-08
8AM2	35					
8AM4	60					

8AM

Designed specifically for motors with a fast rate of temperature rise (25-35°C/sec), the 8AM provides economical protection for a full range of motors and transformers ranging from washing machines to vacuum cleaners; computer disk drives to high capacity automotive motors.

This unique design is capable of providing all mode protection:

- Locked rotor
- Running overload
- Low voltage
- Run both winding

Here's why you should be using the 8AM protector in your product:

- Compact, easy to install
- Individually temperature calibrated and checked
- Positive make-and-break with Klixon® snapaction disc
- Gasketed steel case suitable for many impregnation processes
- Current and temperature sensitivity for maximum design flexibility
- Specially designed terminals for easy addition of wireleads.

Typical applications:

- Split-phase motors
- Capacitor start motors
- Ballast protection
- Transformers
- Automotive motors
- Solenoids

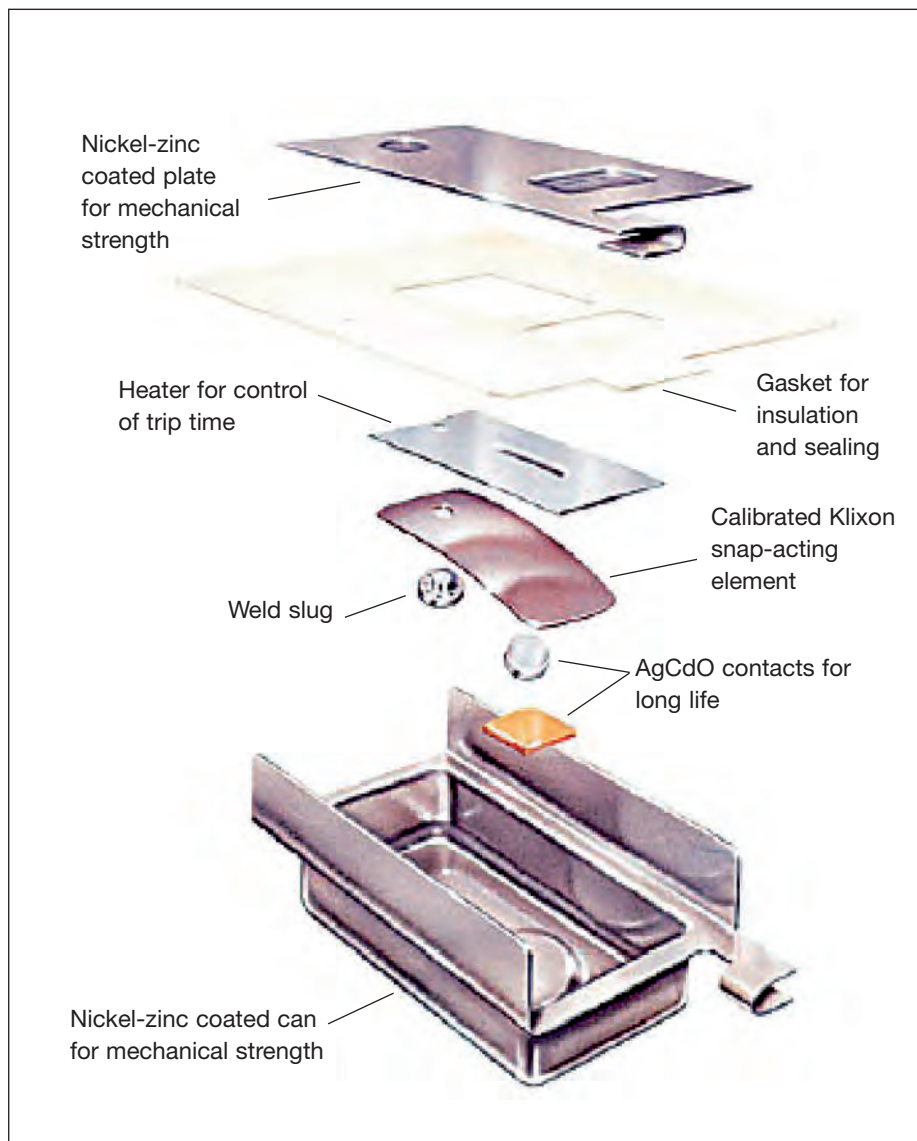



KLIXON | 2MM MOTOR PROTECTOR/THERMAL CUT-OUT

KEY BENEFITS

Field proven reliable and repeatable snap-action bimetal actuation.

Low profile shape for close coupling to on- or in-winding application.

On customers request additional sleeve available.

Competitive performance-price ratio

Sensata Technologies builds the 2MM motor protector to meet almost any requirement of protection in a wide range of small motors, small transformers, solenoids, etc..

This compact motor protector is the best solution to protect the wide variety of motors used in industrial and domestic appliances against locked rotor and overload situations.

Design and operating principles

The motor protector 2MM consists of a metal housing that holds and protects the inner components against infiltration as well as mechanical deformation.

The can contains the calibrated Klixon® disc carrying a silver contact. The fixed contact is placed on the opposite side, separated from the terminal by an insulator.

The 2MM is available in two versions: with epoxy insulation and with additional sleeve.

The operating principle of the 2MM is both simple and effective. A current flows through the resistive Klixon® bimetal disc.

When a fault condition occurs, the increased current and ambient temperature make the bimetal disc snap open the contacts. The contacts close again automatically as the device cools down to a safe running temperature.

Applications

The 2MM operates as a sensitive safety cut-out for applications like:

- Small motors
- Coils
- Solenoid valves
- Transformers

In single phase motors it can be mounted directly in the main circuit to serve as on- or in-winding protector. Its compact size provides ease of installation, even in small spaces.

At this time there is practically no small motor the 2MM cannot protect against overheating and overloading. Sensata Technologies 2MM provides you with a cost effective solution in terms of maximum quality and reliability.



SMALL APPLIANCES INDUSTRIAL & LIGHTING

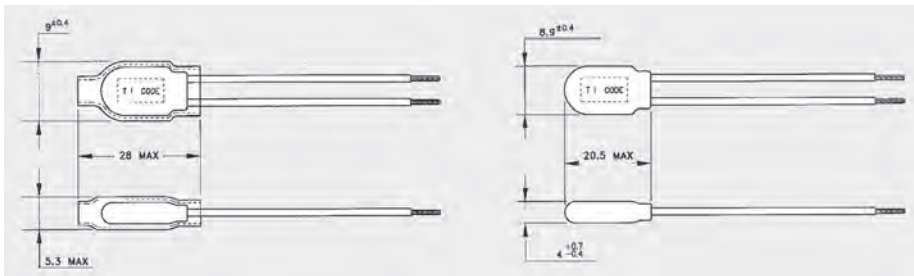

Coding System

(N)2MMT XXX YYY

Standard opening temperature			
70	100	130	160
75	105	135	
80	110	140	
85	115	145	
90	120	150	
95	125	155	

Wire lead code*

* Size and length on customer request

N2MM (naked version)

Available also: Doublet and Triplet types

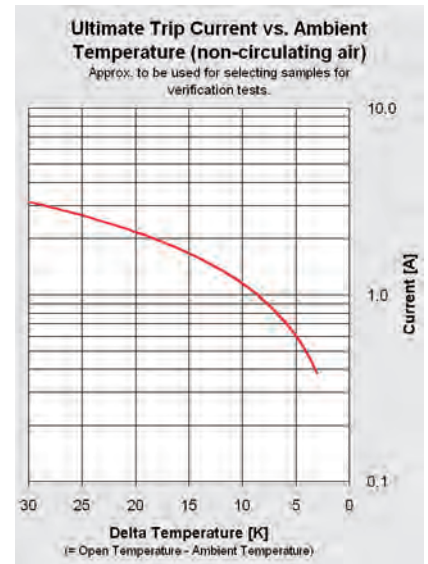

Specifications

Standard operating temperature range from	70°C - 160°C in 5K steps
Tolerance on open temperature	± 10K
Max. Ambient temperature	175°C
Differential	20K minimum

Maximum Contact rating

7.0 (2.0) A 250 Vac
(3.000 cycles)

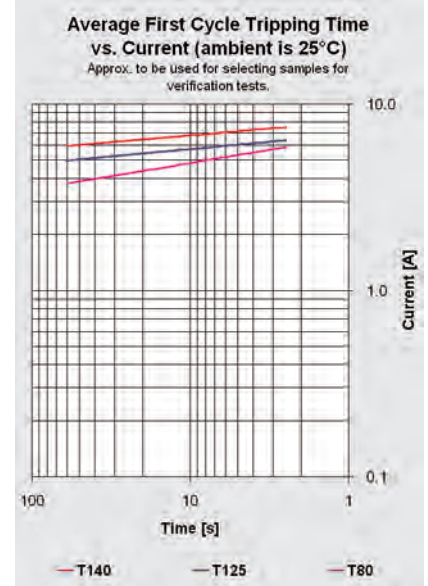

Certifications

Agency	File number	Standard	Note
UL / C-UL	E 15962	UL2111 / CSA C22.2 No. 77	Motor protecting device
ENEC	2014531.06	EN60730-2-9	Thermal Cut-Out
ENEC	2014531.06	EN60730-2-2	Thermal Motor Protector

Declarations

Declarations to EN60730-2-9		Declarations to EN60730-2-2	
Purpose of the control	Thermal Cut-Out	Purpose of the control	Thermal Motorprotector
Construction	Incorporated, non-electronic		
Degree of protection	IP00		
Terminals for ext. conductors	For internal conductors only		
Temperature limits of the sw itchhead	175°C		
PTI of insulation materials	Int: PTI 175 Ext: PTI 250	PTI of insulation materials	Int: PTI 175 Ext: PTI 250
Method of mounting	On-w inding or by special means in the appliance	Method of mounting	On-w inding or by special means in the appliance
Operating time	For continuous operation		
Type of action	Type 2B	Type of action	Type 3C
Reset characteristic	Automatic	Reset characteristic	Automatic
Extent of sensing element	Whole control		
Control pollution degree	Epoxy version: Degree 3 Naked version: Degree 2	Control pollution degree	Epoxy version: Degree 3 Naked version: Degree 2



KLIXON | 3MP MOTOR PROTECTOR/THERMAL CUT-OUT

KEY BENEFITS

Minimizes the total cost of the motor protection function

Maximum protection under locked rotor conditions

Provides extra flexibility during the motor manufacturing process

Reduces the total need of motor protector type; one code for several applications

Provides mounting flexibility

Low cost solution for transformer protection

As world leader in appliance motor protection, Sensata Technologies has developed the 3MP for 120 and 250 Vac applications to operate in wider temperatures and current ranges than offered by existing protection solutions. In providing consistent performance characteristics and excellent reliability, its features anticipate future technical protection requirements on the AC motor market.

Design & operating principles

The 3MP consists of a metal housing with an integrated terminal. The housing holds the pre-set Klixon® snap action bimetal disc. The split plate carries a resistive S-shaped wire which provides additional current sensitivity. The advanced contact system - one on the bimetal disc and one on the plate - in combination with the strong disc guarantees a long life and reliable cycling. The combination of a variety of standard terminal configurations and carefully selected materials provides easy handling and mounting. Customized terminal configurations are available on request. Wires including connectors can be automatically attached to the standard crimp terminal.

Sensata Technologies supplies a range of standard lead configurations; customized solutions are available on request. In construction where the 3MP device is contacting conductive parts of the motor assembly, Sensata Technologies can deliver the devices with a Mylar™ insulation sleeve. Customized coding and colouring of the coding tape is an option on request.

The operating principle of the 3MP is both simple and effective. The protector is actuated by current passing through it

and by the heat received from the surrounding parts. The electrical circuit is interrupted when the disc reaches its pre-set temperature. As the device cools down to a safe temperature, the contacts will automatically reset. The bimetal disc provides excellent thermal and current sensitivity in an overload situation. Under locked rotor conditions the integrated heater in combination with the bimetal disc provide very accurate trip times for maximum protection.

Applications

The 3MP is widely used throughout the world in electric motors for washing machines, dishwashers, dryers, vacuum cleaners and industrial applications in the 120 and 250 Vac applications. 3MP features permit to move the motor protector location outside the winding, providing the motor manufacturer extra flexibility during the manufacturing process. The recent certification as a thermal cut-out device combined with its unique current sensitivity, positions the 3MP as an advanced and cost effective solution to protect toroidal transformers.



SMALL APPLIANCES INDUSTRIAL & LIGHTING

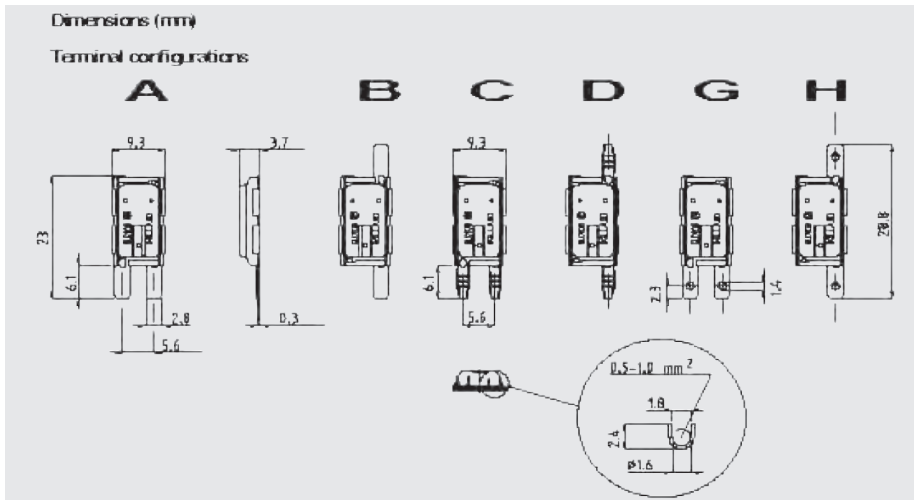

The curves of First Cycle Tripping time and Ultimate trip current are meant to be for selecting samples to perform verification tests only. In the figures two curves of a wide range of possibilities are shown. The level and slope can be varied by making an other selection for the pre-set temperature, bimetal disc and/or heater.

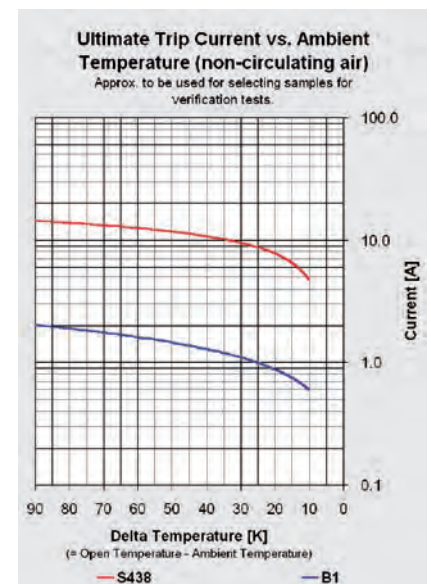
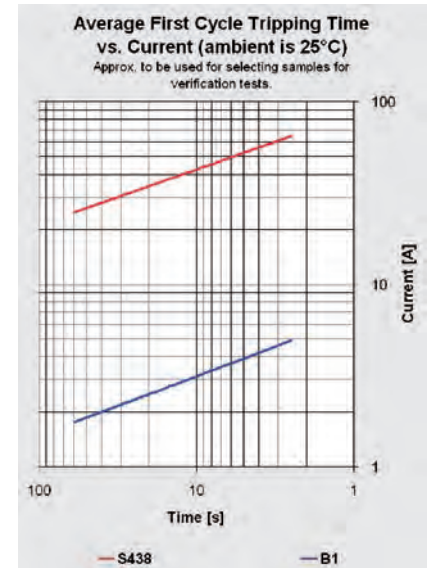

Specifications

Standard operating temperature range	from 80°C - 170°C (Increments 5K)
Tolerance on open temperature	± 5K
Peak temperature (5 min)	200°C
Max. Ambient temperature	T-open +20°C
Time check at T-ambient 25°C	4 to 10 seconds
Contact rating	27.5 A @cos 1 / 250Vac / 500 cycles 18 A @cos 0.6 / 250Vac / 1.000 cycles 18 A @cos 0.6 / 120Vac / 15.000 cycles

Certifications

Agency	File number	Standard
ENEC	2014531.07	EN60730-2-2 Thermal motor protector
ENEC	2014531.07	EN60730-2-9 Thermal cut-out
UL / C-UL	E15962	UL2111/ CSA-C22.2 No. 0-M91

Declarations

Declarations to EN60730-2-9	Declarations to EN60730-2-2
Purpose of the control.....Thermal cut-out	Purpose of the control.....Thermal Motorprotector
Construction.....Incorporated, non-electronic	
Degree of protection.....IP00	
Terminals for ext. conductors.For internal conductors only	
Method of (dis) connection of terminals.....Soldering, spotwelding	
Temperature limits of the switchhead.....170°C	
PTI of insulation materials.....PTI 175	PTI of insulation materials.....PTI 175
Method of mounting..... Off-winding, fixed position, no mounting limitation	Method of mounting..... Off-winding, fixed position, no mounting limitation
Operating time.....For continuous operation	
Type of action.....Type 2B	Type of action.....Type 3C
Reset characteristic.....Automatic	Reset characteristic.....Automatic
Extent of sensing element....Whole control	
Control pollution degree.....Degree 1	Control pollution degree.....Degree 2



KLIXON | 3MP Self-Hold MOTOR PROTECTOR

KEY BENEFITS

Provides higher level of safety for appliances having free access to rotating parts

Minimizes the total cost of the motor protection function

Guarantees to pass the UL 18 days locked rotor test in combination with high currents

Provides mounting flexibility

Assures maximum protection under locked rotor conditions

Sensata Technologies Engineering knowledge base

European supply

Recent history has seen a growing demand for a non-self resetting motor protection device to ensure a high level of safety. Sensata Technologies has developed the self hold motor protector for both 120 & 250 Vac applications in a wide current range.

Design & operating principles

The heart of the 3MP self hold consists of the pre-set Klixon® snap action bimetallic disc welded into a metal housing with integrated terminal. The housing is covered by the plate on which a heater can be welded to increase the current sensitivity of the device. A PTC pill is mounted on top of the metal housing by a clip to meet the requirements for self hold.

The combination of a variety of standard terminal configurations and carefully selected materials provides easy handling and mounting. Customized terminal configurations are available on request. Wires including connectors can be automatically attached to the standard crimp terminals.

Sensata Technologies supplies a range of standard leads configurations; customized solutions are available on request.

In construction where the 3MP self hold device is contacting conductive parts of the motor assembly, Sensata Technologies can deliver the self hold devices with a Mylar™ insulation sleeve. Customized coding and coloring is an option on request.

The operating principle of the 3MP self hold is both simple and effective. The protector is actuated by current passing through it and by the heat received from surrounding parts.

The electrical circuit is interrupted when the disc reaches its pre-set open temperature. Due to the heat supply from the PTC pill, the bimetal disc does not cool down below the close temperature. The contacts will remain open until the appliance switched off by the user, assuring a higher level of safety. When switched off the device cools down to a safe temperature again and the contacts will automatically reset. The bimetal disc provides excellent thermal and current sensitivity in overload situation. Under locked rotor conditions the integrated heater in combination with the bimetal disc provide very accurate trip times for maximum protection.

Applications

The 3MP self hold is used in domestic and industrial electric motors for washers, vacuum cleaners, chain saws, trimmers, lawn mowers and pumps in the 120 and 250 Vac applications.

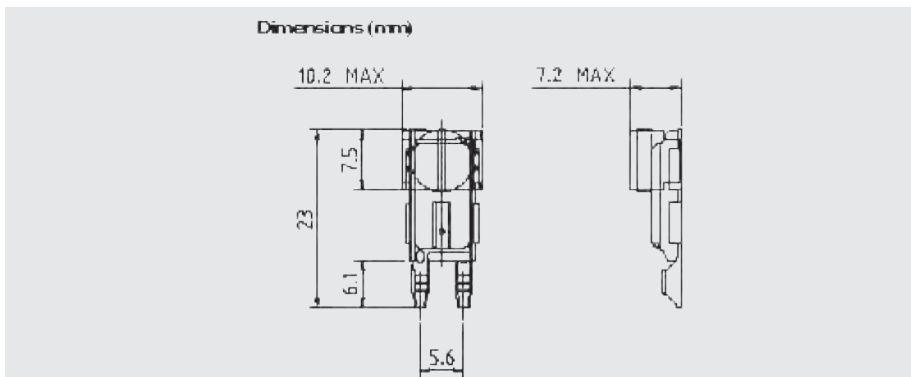

The curves of First Cycle Tripping time and Ultimate trip current are meant to be for selecting samples to perform verification tests only. In the figures two curves of a wide range of possibilities are shown. The level and slope can be varied by making an other selection for the pre-set temperature, bimetal disc and/or heater.

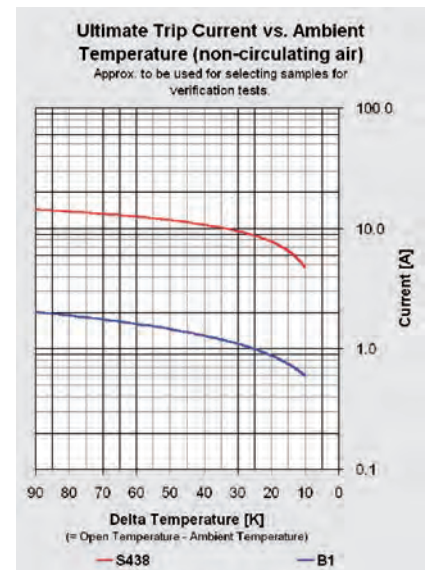

Specifications	
Standard operating temperature range	from 80°C - 170°C (Increments 5K)
Tolerance on open temperature	± 8K
Max. Ambient temperature	T-open +20°C
Ambient temperature to guarantee stable Self Hold function	0°C
Peak temperature (5 min)	200°C
Time check at T-ambient 25°C	4 to 10 seconds depending on current level
Contact rating	18 A @ cos 0.6 / 250Vac / 300 cycles

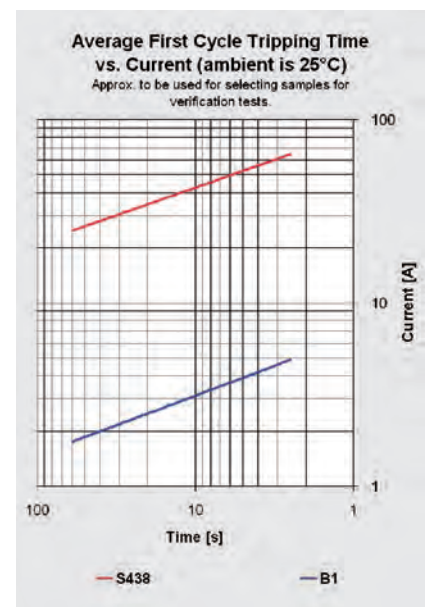

Declarations	
Declarations to EN60730-2-2	
Purpose of the control.....	Thermal Motorprotector
PTI of insulation materials.....	PTI 175
Method of mounting.....	Off-winding, fixed position, no mounting limitation
Type of action.....	Type 3C
Reset characteristic.....	- Automatic - Voltage maintained by PTC heater. Device resets by interrupting power supply
Control pollution degree.....	Degree 1

Certifications		
Agency	File number	Standard
ENEC	2014531.07	EN60730-2-2 Thermal motor protector
UL / C-UL	E15962	UL2111 / CSA C22.2 No. 77



KLIXON | 4CR

MOTOR STARTING RELAY

All position current-type

KEY BENEFITS

Reliable operation and long life independent of mounting position

Wide range of pick-up and drop-out ratings

Start-winding current rating - 25 amps

Small size for installation in compact equipment

Economical

The Klixon 4CR current type motor starting relay is a compact, high capacity relay, designed for universal application to splitphase and capacitor start, single-phase motors with start-winding currents up to 25 amperes.

Construction

The 4CR relay utilizes a balanced armature to provide positive operation independent of mounting position. Double-break bonded Top-lay contacts provide excellent electrical and thermal conductivity to provide the high switching capacity and long electrical life. Silver cadmium oxide is used for the 25 amp contacts.

Mounting and Terminals

The 4CR relay's compact size and universal mounting allow cost saving reductions in motor size and elimination of centrifugal switches. Mounting can be in the motor, in the conduit box, or

remote from the motor.

Calibrated in one position for a specific pick-up and drop-out, the 4CR remains within tolerance in all other mounting positions. A variety of mounting brackets, terminals and assembly screw extensions are available to meet any mounting requirements.

Pick-up and Drop-out Ratings

Ratings indicated maximum pick-up and minimum drop-out current limits. Pick-up is the current through the relay coil required to close the relay contacts. Drop-out is the current through the relay coil at which the contacts open. A production relay of a given rating will have a pick-up and drop-out current within the rating limit.

UL Descriptive Report

UL file # SA-3745, 3-8-68
CSA# LR11372

Operation

The 4CR relay coil is in series with the main winding of the motor and the normally open contacts are in series with the start winding. When voltage is applied to the motor, the in-rush current of the main winding through the relay coil creates a magnetic force which rotates the armature. This action closes the relay contacts and energizes the motor start winding. As motor speed increases, the current in the main winding and relay coil decrease to a point where the armature biasing spring force is greater than the decreasing magnetic force, and the armature rotates back to its original position. This opens the relay contacts and disconnects the start winding.

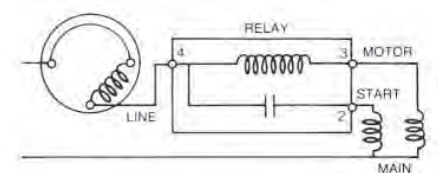

Single Circuit Relay

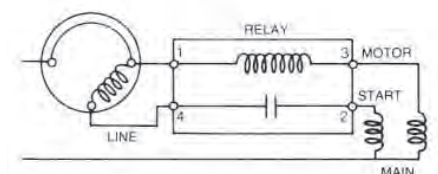

Two Circuit Relay

SMALL APPLIANCES INDUSTRIAL & LIGHTING

Rating Data Table

KLIXON Rating No	Relay Operating Characteristics in Amps		KLIXON Rating No	Relay Operating Characteristics in Amps		KLIXON Rating No	Relay Operating Characteristics in Amps	
	Max. Pick-Up	Min. Drop-Out		Max. Pick-Up	Min. Drop-Out		Max. Pick-Up	Min. Drop-Out
600	1.01	0.83	662	6.30	5.20	724	15.00	12.40
601	1.07	0.88	663	6.40	5.30	725	15.20	12.50
602	1.12	0.93	664	6.50	5.35	726	15.40	12.70
603	1.17	0.97	665	6.60	5.45	727	15.60	12.80
604	1.22	1.01	666	6.70	5.50	728	15.80	13.00
605	1.27	1.06	667	6.80	5.60	729	16.00	13.20
606	1.32	1.10	668	6.90	5.70	730	16.20	13.40
607	1.38	1.13	669	7.00	5.80	731	16.40	13.50
608	1.42	1.17	670	7.10	5.90	732	16.60	13.70
609	1.47	1.22	671	7.20	5.90	733	16.80	13.90
610	1.53	1.27	672	7.30	6.00	734	17.00	14.00
611	1.58	1.30	673	7.40	6.10	735	17.30	14.30
612	1.63	1.35	674	7.50	6.20	736	17.50	14.40
613	1.68	1.38	675	7.60	6.30	737	17.70	14.60
614	1.73	1.43	676	7.70	6.30	738	17.90	14.80
615	1.78	1.47	677	7.80	6.40	739	18.10	14.90
616	1.83	1.51	678	7.90	6.50	740	18.30	15.10
617	1.88	1.55	679	8.00	6.60	741	18.50	15.30
618	1.93	1.59	680	8.10	6.70	742	18.70	15.40
619	1.98	1.64	681	8.20	6.80	743	18.90	15.60
620	2.03	1.68	682	8.30	6.80	744	19.10	15.80
621	2.13	1.76	683	8.40	6.90	745	19.30	15.90
622	2.23	1.84	684	8.50	7.00	746	19.50	16.10
623	2.33	1.92	685	8.60	7.10	747	19.70	16.30
624	2.43	2.02	686	8.70	7.20	748	19.90	16.40
625	2.54	2.10	687	8.80	7.30	749	20.10	16.60
626	2.63	2.17	688	8.90	7.40	750	20.30	16.70
627	2.74	2.26	689	9.00	7.50	751	20.50	16.90
628	2.85	2.35	690	9.10	7.50	752	20.70	17.10
629	2.95	2.45	691	9.20	7.60	753	20.90	17.20
630	3.05	2.50	692	9.30	7.70	754	21.10	17.40
631	3.15	2.60	693	9.40	7.80	755	21.30	17.60
632	3.25	2.70	694	9.50	7.80	756	21.50	17.70
633	3.35	2.75	695	9.60	7.90	757	21.70	17.90
634	3.45	2.85	696	9.70	8.00	758	21.90	18.10
635	3.55	2.95	697	9.80	8.10	759	22.10	18.20
636	3.65	3.05	698	9.90	8.20	760	22.30	18.40
637	3.75	3.10	699	10.00	8.30	761	22.50	18.60
638	3.85	3.20	700	10.20	8.40	762	22.70	18.80
639	3.95	3.30	701	10.40	8.60	763	22.90	18.90
640	4.05	3.35	702	10.60	8.70	764	23.10	19.10
641	4.15	3.45	703	10.80	8.90	765	23.30	19.20
642	4.25	3.55	704	11.00	9.10	766	23.60	19.50
643	4.35	3.60	705	11.20	9.20	767	23.90	19.70
644	4.45	3.70	706	11.40	9.40	768	24.30	20.10
645	645	3.80	707	11.60	9.60	769	24.60	20.30
646	646	3.85	708	11.80	9.70	770	25.00	20.60
647	647	3.95	709	12.00	9.90	771	25.30	20.90
648	648	4.00	710	12.20	10.10	772	25.60	21.10
649	649	4.10	711	12.40	10.20	773	26.10	21.50
650	5.10	4.20	712	12.60	10.40	774	26.40	21.80
651	5.15	4.25	713	12.80	10.60	775	26.70	22.00
652	5.25	4.35	714	13.00	10.70	776	27.10	22.30
653	5.40	4.45	715	13.20	10.90	777	27.40	22.60
654	5.50	4.55	716	13.40	11.00	778	27.90	23.00
655	5.60	4.60	717	13.60	11.20	779	28.40	23.40
656	5.70	4.70	718	13.80	11.40	780	28.90	23.90
657	5.80	4.75	719	14.00	11.50	781	29.40	24.30
658	5.90	4.85	720	14.20	11.70	782	29.90	24.70
659	6.00	4.95	721	14.40	11.90	783	30.40	25.10
660	6.10	5.05	722	14.60	12.10	784	31.00	25.50
661	6.20	5.15	723	14.80	12.20	785	31.50	26.00

How To Order

Specify:

1. KLIXON part number 4CR, Select maximum pick-up and minimum drop-out current values and specify rating number from table.
2. Motor start winding current, voltage and frequency.
3. Terminals and mounting bracket required.

Sample Code

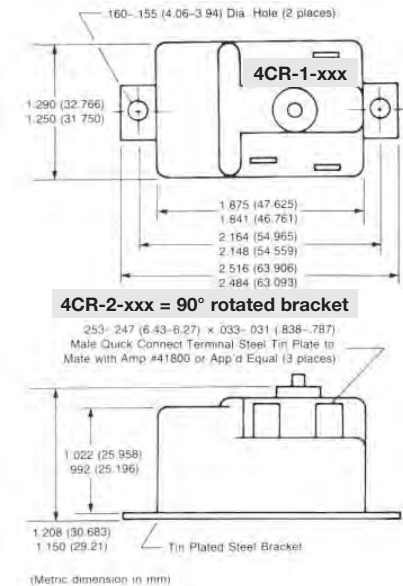
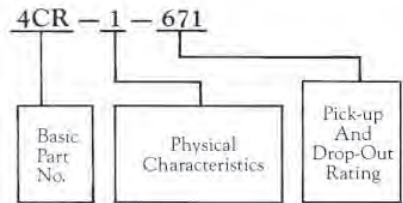



KLIXON | 7AM THERMAL PROTECTORS

KEY BENEFITS

Over 3 billion sold

Miniature size

Individually temperature checked on modern, custom-designed equipment

Positive make and break with Klixon® snapaction disc

Repeatable temperature performance over life

Gasketed steel case suitable for most impregnation processes

Current and temperature sensitivity for maximum design flexibility and application

Wide selection of leads and insulating sleeves

The Klixon® 7AM Thermal Protector is the market leader, backed by proven innovations in protection technology. The 7AM is a thermally operated snapaction device which delivers the maximum protection in the smallest package at an affordable price.

The 7AM is a proven performer in protection technology with over 35 years of design experience combined with a modern state-of-art manufacturing facility.

Operation

The operating principle of the 7AM is both simple and effective. At the heart of the protector is a Klixon® bimetal snapaction disc. When the temperature of this disc reaches its precalibrated temperature it snaps open, resulting in an open circuit. This temperature is reached during a fault condition, caused by either an increase in ambient temperature, an increase in current flowing thru the disc, or a combination of both. After the 7AM breaks the circuit, the system cools and the 7AM automatically resets allowing power to be restored in the circuit.

Quality

Each 7AM rating has a bimetal disc designed and manufactured for the specific temperature rating. Each individual device is then calibrated and checked for opening temperature. This results in precise operating characteristics necessary to achieve consistent, reliable performance over the required life cycle.

This high level of performance is obtained thru Sensata Technologies traditional emphasis on quality. A corporate-wide thrust, re-emphasizes the supplier's responsibility and integrates modern statistical techniques into the production and quality assurance processes. As continuous inputs to the quality monitoring systems, more than 12 different checks are made during the manufacturing process.

Applications

- Shaded pole motors
- Permanent split capacitor motors
- Fluorescent lighting ballasts
- HID ballasts
- Transformers
- Recessed lighting fixtures
- Battery packs
- Vacuum cleaners
- Automotive accessory motors, solenoids, PC boards and other applications

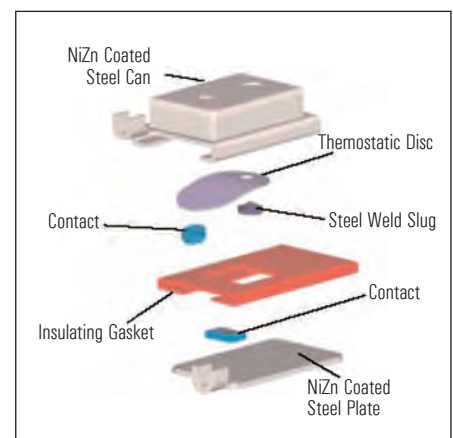

SMALL APPLIANCES INDUSTRIAL & LIGHTING

Dimensions Inches (Millimeters)

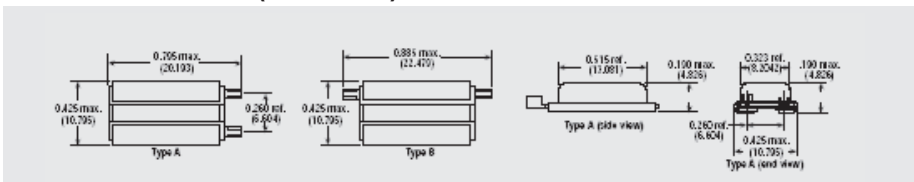

Numbering System

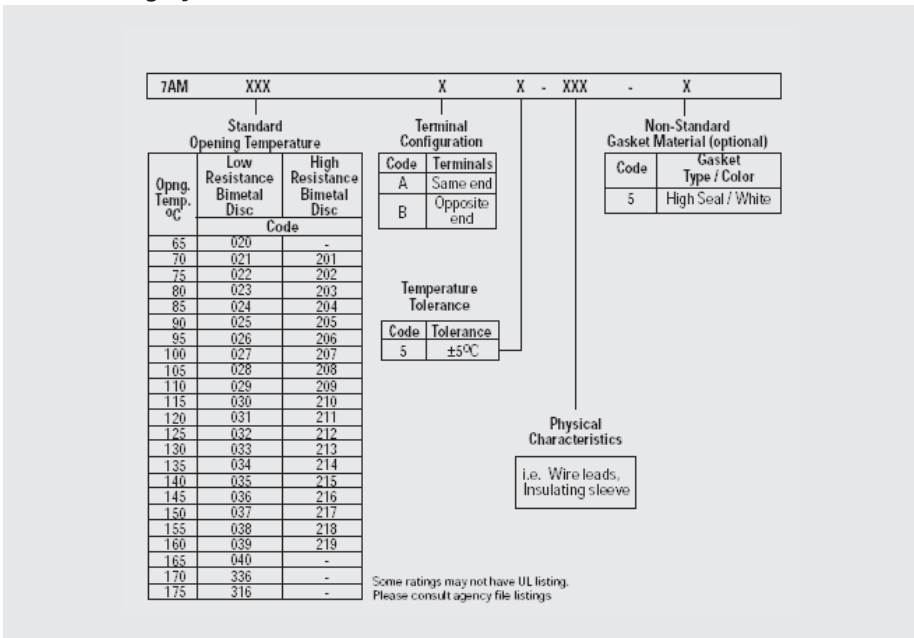

Ultimate Trip Current vs. Delta Temperature

Approximation, to be used only for selecting samples for verification tests.

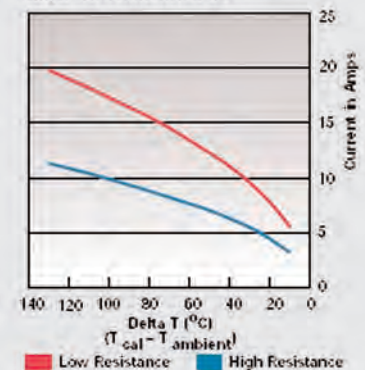

Note: Delta T is the difference between the zero current calibrated opening temperature (T_{cal}) and ambient temperature ($T_{ambient}$) at the protector location.

Average First Cycle Tripping Time vs. Current (25°C Ambient)

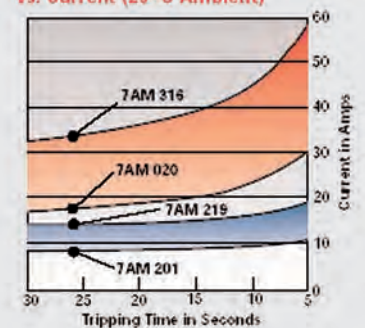

Certifications

Agency	File number	Standard Number	Application
UL	E 15962	2111	Motor Protection
	E 34618	873	Limit and regulating controls
CSA	11372	C22.2, #77	Motor Protection
	24458	C22.2, #77	Limit and regulating controls
KEMA(ENEC)	2014531.03	EN60730-2-2	Motor Protection
		EN60730-2-3	Ballast Protection
		EN60730-2-9	Thermal cut-out

Maximum Contact Ratings (10,000 Cycles)

Voltage	Current
16 VDC	20 amperes
120 VAC	22 amperes
120 VAC	22 amperes
120 VAC	22 amperes



KLIXON | 15AM MOTOR PROTECTOR/THERMAL CUT-OUT

KEY BENEFITS

- Sensata Technologies
- Engineering knowledge base
- Provides mounting flexibility
- European supply
- Competitive price
- Local Engineering

As world market leader in appliance motor protection Sensata Technologies builds the 15AM motor protector to meet almost any application in this field. The 15AM is designed to provide locked rotor and overload protection in a wide variety of motors for industrial and domestic appliances. The 15AM is a leader in the European AC motor protection market.

Design & operating principles

In the 15AM design the nickel plated shell holds and protects the inner components against varnish penetration and mechanical forces. The heart of the device is the calibrated Klixon® bimetal disc, responding to current and temperature changes. It is supported by a slug and a contact welded on the disc. The fixed contact is placed on the opposite nickelzinc coated plated steel shell, separated by a coated gasket for insulating and sealing. The 15AM can be supplied as a basic device with leads and other integrated quick connectors or automated connection systems. Customized lead configurations are available on request. The 15AM can be fitted in the best possible mounting location in com-

ination with the optimum assembly operation. As the 15AM is a metal device it may be necessary to insulate the device from other conductive parts. An insulating sleeve is available on request.

The operating principle of the 15AM is both simple and effective. A current flows through the resistive Klixon® bimetal disc. When a fault condition occurs, the increased current and shell temperature heats up the bimetal disc which snaps and opens the contacts. As the device cools down to a safe temperature, the contacts will automatically reset.

Applications

The 15AM operates as an incorporated thermal sensitive protector in electric motors for pumps, washing machines, dish washers, dryers, vacuum cleaners, fans, battery chargers and microwave ovens.

Specifications

Standard operating temperature range	from 65°C - 170°C
Tolerance on open temperature	± 5K
Maximum Ambient temperature	180°C
Maximum terminal temperature	185°C

Certifications

Agency	File number	Standard	Rating
ENEC	2014531.04	EN60730-2-9 Thermal Cut-Out	13 (5) A 250Vac / 10.000 cycles
ENEC	2014531.04	EN60730-2-2 Thermal Motor Protector	
UL / C-UL	E 15962	UL2111/CSA C22.2 No.77	



SMALL APPLIANCES INDUSTRIAL & LIGHTING

Dimensions (mm)

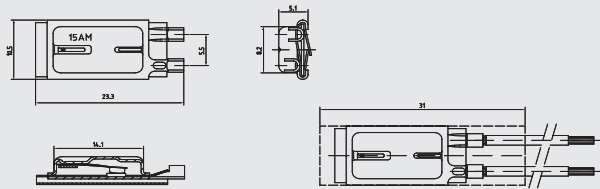

Coding System

15AM	345	A	034	A	
Sealing		Standard Lead coding		Sleeve coding	
Code	Type	Length (mm)	Code	Code	Type
A	Standard	55	031	A	Standard
B	Hotmelt sealed	60	032		No sleeve
		65	033		
		70	034		
		75	035		
		80	036		
		90	037		
		100	038		
		110	039		
		125	040		
		140	041		
		160	042		
		180	043		
		210	044		
		240	045		
Others on request					

Standard opening temperature												
Specific Bimetal resistivity	30		70		100		250		500		850	
	20 K	45 K	20 K	45 K	20 K	45 K	20 K	45 K	20 K	45 K	20 K	45 K
Opening Temp*	006	305	007	008	009	009	009	009	060	065		
65°C	011	310	012	013	014	014	014	014	075	080		
70°C	016	315	017	018	019	019	019	019	085	090		
75°C	021	320	022	023	024	024	024	024	090	095		
80°C	026	325	027	028	029	029	029	029	095	100		
85°C	036	335	037	038	039	039	039	039	100	105		
90°C	046	345	047	048	049	049	049	049	105	110		
95°C	056	061	355	360	057	062	058	063	059	064	060	065
100°C	071	076	370	375	072	077	073	078	074	079	075	080
105°C	086	091	385	390	087	092	088	093	089	094	090	095
110°C	106	405	405	410	107	112	108	113	109	114	110	115
115°C	121	420	420	425	122	127	123	128	124	129	125	130
120°C	136	435	435	440	137	142	138	143	139	144	140	145
125°C	151	450	450	455	152	157	153	158	154	159	155	160
130°C	166	465	465	470	167	172	168	173	169	174	170	175
135°C	181	480	480	485	182	187	183	188	184	189	185	190
140°C	196	495	495	500	197	202	198	203	199	204	200	205
145°C	211	510	510	515	212	217	213	218	214	219	215	220
150°C		520	520	525	222	227	223	228	224	229	225	230
155°C		530	530	535	232	237	233	238	234	239	235	240
160°C		540	540	545	242	247	243	248	244	249	245	250
165°C		550	550	555	252	257	253	258	254	259	255	260
170°C					252	257	253	258	254	259	255	260

* Opening temperature tolerance $\pm 5K$
 ** Nominal differential equals nominal opening temp. minus nominal closing temp.
 Tolerance on closing temperature: 20K differential $\pm 10K$
 45K differential $\pm 15K$

Declarations

Declarations to EN60730-2-9		Declarations to EN60730-2-2	
Purpose of the control	Thermal Cut-Out	Purpose of the control	Thermal Motorprotector
Construction	Incorporated, non-electronic		
Degree of protection	IP00		
Terminals for ext. conductors	For internal conductors only		
Temperature limits of the switchhead	180°C		
PTI of insulation materials	PTI 175	PTI of insulation materials	PTI 175
Method of mounting	Inserting, clamping, bracketing or the like	Method of mounting	Inserting, clamping, bracketing or the like
Operating time	For continuous operation		
Type of action	Type 2C (T-open) Type 1C (T - close)	Type of action	Type 3C
Reset characteristic	Automatic	Reset characteristic	Automatic
Extent of sensing element	Whole control		
Control pollution degree	Degree 2	Control pollution degree	Degree 2

Ultimate Trip Current vs. Ambient Temperature (non-circulating air)

Approx. to be used for selecting samples for verification tests.

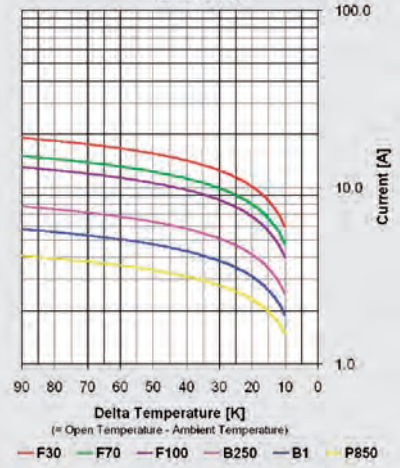

Average First Cycle Tripping Time vs. Current (ambient is 25°C)

Approx. to be used for selecting samples for verification tests.

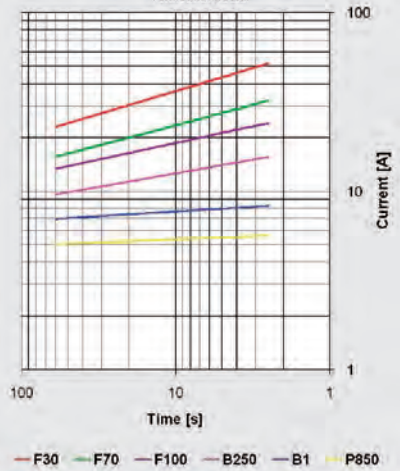



KLIXON | 17AM THERMAL PROTECTOR FOR MOTOR

Ballast for Fluorescent and Temperature Sensing Controls

KEY BENEFITS

- Sensata Technologies
- Engineering knowledge base
- Provides mounting flexibility
- European supply
- Competitive price
- Local Engineering

The Sensata Technologies 17AM delivers the maximum protection in the smallest package at an excellent price... The KLIXON 17AM Thermal protector prevents overheating, It's a miniature, snap acting, thermally operated device that is a proven performer in protection technology. It protects against overheating in:

- Shaded Pole Motor
- Permanent split capacitor motor
- Fluorescent lighting ballasts
- HID ballasts
- Transformer
- Recessed lighting fixtures
- Battery packs
- Vacuum cleaners
- Automotive accessory motors, solenoids, PC boards and other applications

Here's why you should be using Sensata Technologie 17AM Thermal Protectors in your product:

- Miniature size.
- Individually temperature calibrated and checked.
- Positive make and break with Klixon snap action disc.

- Repeatable temperature performance over life.
- Gasket steel case suitable for many impregnation processes.
- Current and temperature sensitivity for maximum design flexibility.
- Wide selection of leads and insulating sleeves.
- Same size and opposite side terminations.
- Cadmium free contacts

Operation

The 17AM Thermal protector uses the same snap-action principle of other KLIXON protectors. The bimetal disc senses both heat and current from the equipment which 17AM is installed on. When the temperature of the disc reaches a predetermined calibration point, the disc snaps open the contacts, thus breaking the current path. When the equipment returns to a normal operating range, the 17AM protector resets (close circuit) automatically.

Construction and Configuration is as shown below.

A-type Construction

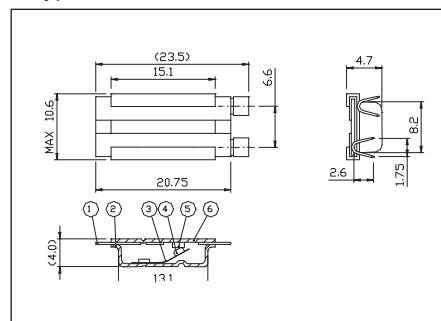

A-type Configuration

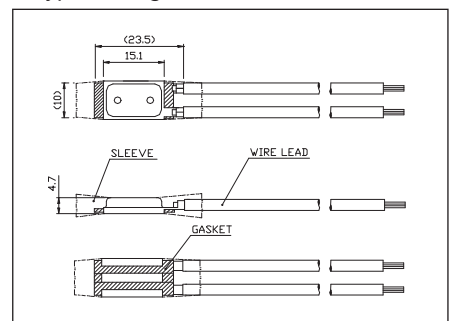

SMALL APPLIANCES INDUSTRIAL & LIGHTING

Unique Type Reference

It is clearly defined the numbering system to find what user needs to know as follows.

17AM XXX Y Z - ZZ

ZZ : Lead length
Serial number is assigned for each lead length and configuration. No number identifies bare device.

Z : Open Temperature Tolerance
5 : $\pm 5^{\circ}\text{C}$
8 : $\pm 8^{\circ}\text{C}$
10 : $\pm 10^{\circ}\text{C}$

Y : Termination Configuration
A/J: Terminals on same side
B/K: Terminals on opposite side
E: Terminals on same side with longer gasket and terminals
H: Terminals on opposite side with longer gasket and terminals

Example :

17AM033A5-4

Bimetal of 70ohms/cm^f, 130°C opening temperature, 5°C tolerance with 66.7mm length leads.

XX : Open Temperature
3 digit number for opening temperature

Nominal Operating Temperature	Type of Bimetal Disc (ohms/cm ^f)			
	70	125	350	468
	Temperature Code			
65	020	060	-	-
70	021	061	161	201
75	022	062	162	202
80	023	063	163	203
85	024	064	164	204
90	025	065	165	205
95	026	066	166	206
100	027	067	167	207
105	028	068	168	208
110	029	069	169	209
115	030	070	170	210
120	031	071	171	211
125	032	072	172	212
130	033	073	173	213
135	034	074	174	214
140	035	075	175	215
145	036	076	176	216
150	037	077	177	217
155	038	078	178	218
160	039	079	179	219

17AM : Device Identification

Technical Characteristics

Contact Capacity:	125Vac18A for TCO 250Vac9A for TCO 250Vac1A for TBP
Temperature Range:	65°C to 160°C for TCO/TMP 65°C to 135°C for TBP
Tolerance on Open Temp:	+/- 5K, +/- 8K or +/- 10K
Max. temp. of the switch head:	max.160°C
Automatic Action:	Type3C for motor Type2C for ballast Type2B for TCO
Operating time:	Continuous
Pollution Situation:	Normal
Extent of sensing element:	whole control
PTI for Insulation:	250
Degree of protection:	IP00
Electrical connections:	On winding, Inserting, Clamping, Bracketing or like

Certifications

Category	UL	ENEC	CQC
Motor Protector	E15962	2014531.05	CQC0200 2001332
Ballast for Fluorescent and Thermal Cut Out	E34618	2014531.05	-
Temperature Sensing Controls	E34618	2014531.05	-

Protectors are not registered in CCC(China Compulsory Certification) products list at present.

CQC(China Quality Certification Centre) is a national certification body in China.



KLIXON | 9700

Thermal Protector for Motor/Fluorescent ballasts and Temperature Sensing Controls

KEY BENEFITS

Miniature size-compact design assures ease of installation

Precision Calibration-temperature calibrated and inspected in controlled ambients for dependable consistent performance

Snapaction-positive make and break assured with proven Klixon® strip disc...contact pressure at open temperature eliminates nuisance trips due to vibration

Sealed steel case-withstands impregnation and baking... maybe varnish dipped... prevents changes in calibration during installation

The Klixon® 9700 protector is a field proven miniature protector developed to protect shaded pole and permanent split capacitor motors, fluorescent ballasts, solenoids, transformers and other electrical equipment against over-heating.

In addition to being small and light-weight, the unit is both temperature and current sensitive. Since the 9700 is sealed to withstand varnish dipping, it can be mounted directly in windings where it can best sense the true temperature of the electrical equipment. As a result, over-temperature protection is assured.

Since the case is not electrically insulated, the protector is furnished with a durable Mylar insulating sleeve. Shrinkable and non-shrinkable sleeves are available.

Technical Characteristics

Purpose of control:	thermal motor protector (TMP) thermal ballast protector (TBP) thermal cut-out (TCO)
Contact capacity:	250VAC 13A for TCO 250VAC 2A for TBP
Temperature range:	60°C to 150°C for TCO and TMP 60°C to 135°C for TBP
Tolerance on Open temp:	+/- 5K or +/- 8K
Automatic action:	Type 3C for TMP Type 2C for TBP and TCO
Operating time:	Continuous
Pollution situation:	Normal
Extent of sensing element:	Whole control
PTI of the insulation:	175
Enclosure protection degree:	IP00

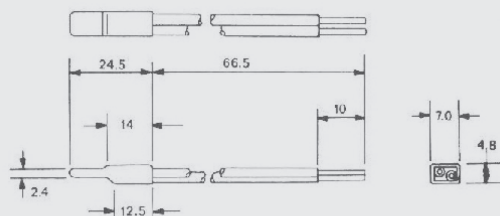

SMALL APPLIANCES INDUSTRIAL & LIGHTING

9700 X X YY -ZZZZ

Z : Wire Lead and sleeve
Serial number is assigned for each lead and sleeve configuration, i.e. wire type, length, AWG#, stripped length, sleeve type, and length.

Y : Operating temperature and actuation disc material
Serial number is assigned for each desired temperature and resistance rating.

Nominal operating temperature	Resistance of actuation disc (ohms/cm ²)				
	30	250	850	100	475
60°C	56	57	58	59	60
80°C	91	92	93	94	95
90°C	21	22	23	24	25
100°C	26	27	28	29	30
110°C	36	37	38	39	40
120°C	1	2	3	4	5
130°C	11	12	13	14	15
140°C	66	67	68	69	70
150°C	46	47	48	49	50

This is a typical temperature code. There is a temperature code at each 5 °C in a step from 60 to 150 °C

X : Open Temperature tolerance
: ± 5K
2 : ± 5K

X : Contact Material Combination
- Both H+K are CD-Free
- K will be used for new part number setup

Note: We only provide H / K type devices. K type when new part number is defined and setup.

9700 : Device Identification

Example :
9700K01-215

Bimetal of 30 ohms/cm²,
120°C operation temperature,
± 5K tolerance with
AWG#18(UL3343 125C-600V)
66.7mm length leads,
thick 0.15mm, dia 6.9mm,
length 34mm, Mylar sleeve.

Certifications

Agency	File number	Standard	Note
UL	E 15962	UL2111	Motor protector
ENEC	2014531.10	EN60730-2-9	Thermal cut-out
ENEC	2014531.10	EN60730-2-2	Thermal motor protector
ENEC	2014531.10	EN60730-2-3	Thermal ballast protector
CQC	CQC0200	2001344	

Ultimate trip current vs ambient temperature

Approx., to be used only for selecting samples for verification tests

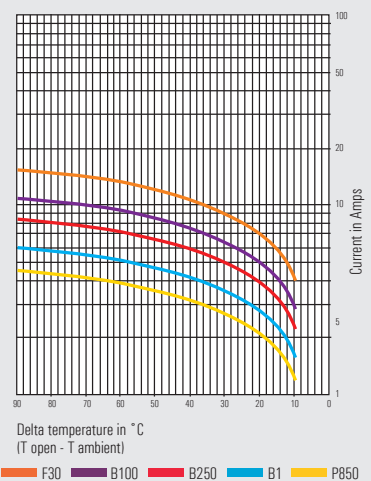

Average first cycle tripping time vs current 25 °C. ambient

Approx., to be used only for selecting samples for verification tests

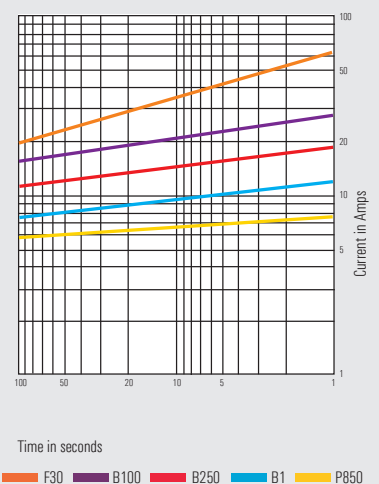



KLIXON | MA10 THERMAL CUT-OUT

KEY BENEFITS

Small Size

Fast thermal response

Bimetal disc exposed

Low cost

Since 30 years the Sensata Technologies MA10 temperature cutout is providing a reliable protection in a variety of small domestic and personal care appliances. The MA10 has set the world standard in the field of open type temperature cut-outs.

Design and operating principles

The Klixon® bimetal disc with welded-on contact is the heart of the MA10. It is welded on the upper terminal which is riveted to the plastic base. The lower terminal carries the stationary contact and is also riveted to the phenolic base.

The operating principle of the MA10 is both simple and effective. Its open structure allows optimum thermal response. When a fault condition occurs, the increased ambient temperature causes the Klixon® bimetal disc to snap open the contacts. As the device cools down to a safe temperature again, the contacts will automatically reset. The MA10 is available with a wide range of calibrated pre-set operating temperatures (with varying tolerances). Since the current flows through the bimetal disc, changing the bimetal resistivity makes it possible to vary the

product's current sensitivity. A high, middle and low current-sensitive bimetal disc is available at no additional charge.

Applications

The MA10 is a temperature-sensitive safety cut-out for applications like:

- Electric room heaters
- Hair dryers
- Hand dryers
- Hair curlers

Due to its compact design, the MA10 can be mounted easily and with its wide range of operating temperatures and tolerances it provides cost-effective and reliable protection

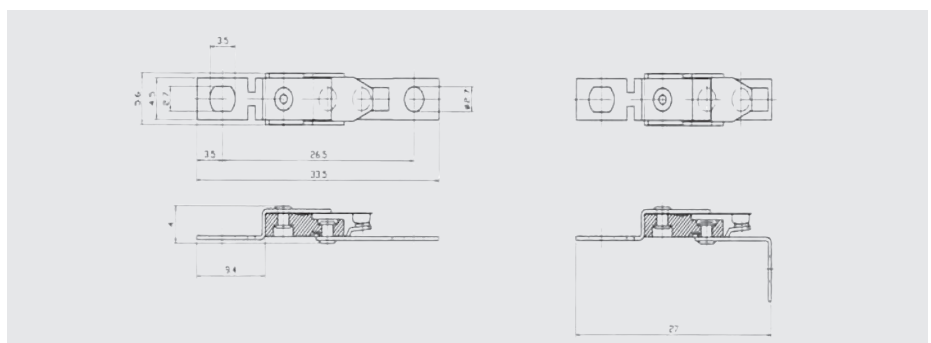

SMALL APPLIANCES INDUSTRIAL & LIGHTING

Coding System

MA10		AA		-		031		-		1	
Terminal Configuration		Standard opening temperature				Opening Temp. tolerance					
Code	Terminals	Operating Temp.	Low resistivity bimetal disc (F30)	Medium resistivity bimetal disc (B1)	High resistivity bimetal disc (P850)						
AA	Both terminals straight	60°C	056	060	058		± 15K				
		65°C	096	100	098		± 10K				
		70°C	071	075	073		± 7.5K				
		75°C	051	055	053		± 5K				
		80°C	091	095	093						
		85°C	061	065	063						
		90°C	021	025	023						
		95°C	031	035	033						
		100°C	026	030	028						
		105°C	016	020	018						
		110°C	036	040	038						
		115°C	041	045	043						
		120°C	001	005	003						
		125°C	081	085	083						
		130°C	011	015	013						
		135°C	006	010	008						
		140°C	066	070	068						
		145°C	076	080	078						
		150°C	046	050	048						

Ultimate Trip Current vs. Ambient Temperature (non-circulating air)

Approx. to be used for selecting samples for verification tests

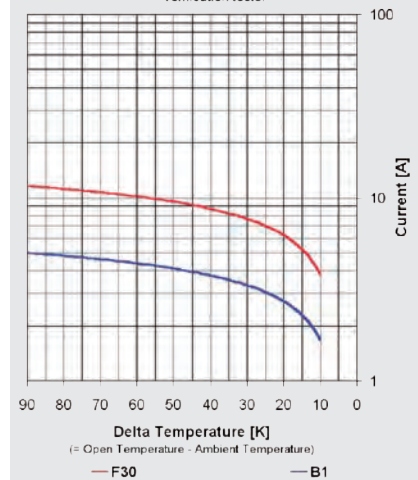

Declarations

Declarations to EN60730-2-9

Purpose of the control	Thermal Cut-Out
Construction	Incorporated, non-electronic
Degree of protection	IP00
Terminals for ext. conductors	For internal conductors only
Method of (dis) connection of terminals	Riveting, soldering, spotwelding
Temperature limits of the switchhead	150°C
PTI of insulation materials	PTI 250
Method of mounting	By various means in conjunction with (holes in) terminals, such that adequate creepage and clearance distances are maintained between live parts and accessible metal parts
Operating time	For continuous operation
Type of action	Type 2C
Reset characteristic	Automatic
Extent of sensing element	Whole control
Control pollution degree	Degree 2

Specifications

Standard operating temperature range	from 60°C - 150°C
Tolerance on open temperature	± 5K/±7.5K/± 10K/± 15K
Max. Ambient temperature	150°C

Certifications

Agency	File number	Standard	Rating A-res (A-ind. @ PF=0.6)IV / cycles
ENEC	2014531.12	EN60730-2-9 Thermal Cut-Out	12(0) 250 / 10.000
UL / C-UL	E54813	EN60730-2-9	9(0.5) 250 / 10.000 18(0.75) 125 / 6.000



KLIXON | RP SERIES THERMAL PROTECTORS

WORLD CLASS PERFORMANCE

The RP Series thermal protector is suited for recessed lighting applications. The RP's compact package is designed to mount on the fixture; and, with sensitivity to changes in thermal conditions, detect the presence of insulation.

With a history of more than 95 years, Sensata Technologies is a leading supplier of sensors and switches.

Features

- Wide variety of UL recognized types
- Automatic resetting device
- Device causes fixture light to blink in fault condition
- Sensitivity to thermal conditions
- 50/60 Hz

Benefits

- Capable of accommodating most recessed lighting fixtures
- Compact design allows for easy placement within the lighting fixture

Sensata Technologies' RP Series of thermal protectors are designed to meet UL, CSA and NEC requirements for the protection of non-IC recessed lighting fixtures. This RP thermal protector is an automatic resetting device that causes the lamp to blink during fault conditions. The RP is controlled by Sensata Technologies' SB600 Series of protectors, which are recognized by UL for tungsten and inductive loads (File E28135) and by CSA for inductive loads (File LR20529).

Sensata Technologies is an ISO and TS registered company providing world class quality products.

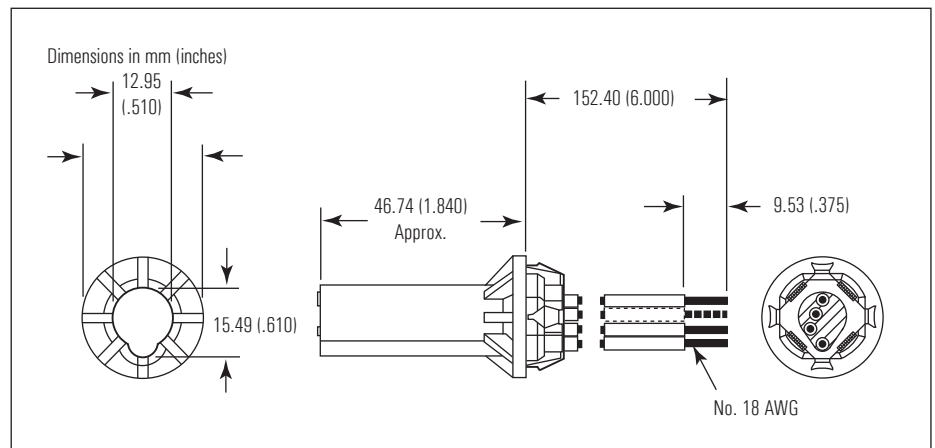

SMALL APPLIANCES INDUSTRIAL & LIGHTING

Electrical and Physical Characteristics

Type	Heater	Sensitivity	No. of Leads	Lead Colors	Heater Wires	Protector Wires	Standard Pack
RP-1B	120V	Low	3	Bk, Wh, Bl	Bl & Wh	Bk & Bl	500
RP-4A	277V	Low	3	Bk, Wh, Red	Red & Wh	Bk & Red	500
RP-5A	120V	Low	4	Bk, Wh, Bl, Red	Red & Wh	Bk & Bl	400
RP-6A	240V	Low	3	Bk, Wh, Grey	Gray & Wh	Bk & Gray	500
RP-7A	208V	Low	4	Bk, Wh, Bl, Yell	Yell & Wh	Bk & Bl	400
RP-8A	120V	Low	3	Bk, Wh, Or	Or & Wh	Bk & Or	500
RP-9A	12V	Low	3	Bk, Wh, Yell	Yell & Wh	Bk & Yell	500
RP-10A	220V	Low	3	Bk, Wh, Viol	Viol & Wh	Bk & Viol	500
RP-11A	120V	High	4	Bk, Wh, Bl, Or	Or & Wh	Bk & Bl	400
RP-12A	277V	High	3	Bk, Wh, Red	Red & Wh	Bk & Red	500
RP-13A	120V	High	3	Bk, Wh, Bl	Bl & Wh	Bk & Bl	500
RP-14A	240V	High	3	Bk, Wh, Grey	Gray & Wh	Bk & Gray	500
RP-15A	208V	High	4	Bk, Wh, Bl, Yell	Yell & Wh	Bk & Bl	400
RP-16A	12V	High	3	Bk, Wh, Yell	Yell & Wh	Bk & Yell	500
RP-17A	220V	High	3	Bk, Wh, Viol	Viol & Wh	Bk & Viol	500
RP-18A	277V	High	4	Bk, Wh, Bl, Or	Or & Wh	Bk & Bl	500

Wiring of RP Thermal Protectors The following instructions will assist in the proper installation of Sensata's RP Series of thermal protectors.

3 Wire RP for Dedicated Voltage

The black lead wire is always connected to the input live wire. The white wire is the common which is permanently connected at the factory with an extra six inch piece of wire of the same color. The third wire of the RP is permanently connected to the live side of the load.

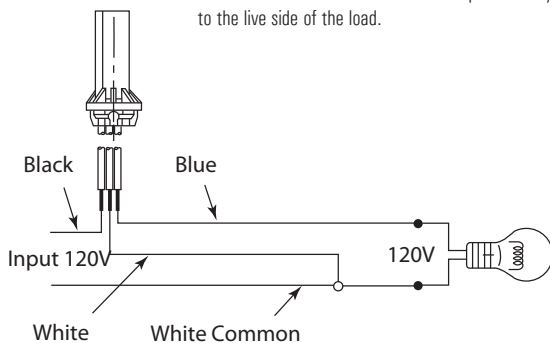

4 Wire RP for Multi-tap Ballasts

The black lead wire is always connected to the input live wire. The white wire is the common which is permanently connected at the factory with all common wires. The red wire of the RP-5A or the orange wire of the RP-11A is connected to the 120 Volt tap of the ballast. The yellow wire of the RP-7A or RP-15A is connected to the 208 Volt tap of the ballast. The orange lead of the RP-18A is connected to the 277 Volt tap. The blue wire is then connected to the tap of the ballast which will match the input voltage. Although the primary usage is 120/277V, the thermal protector inside of these units is rated up to 480 VAC.

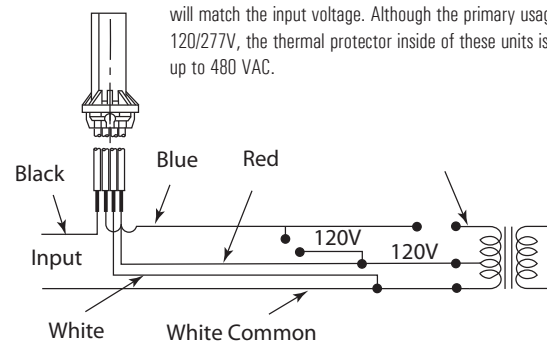

Applications of RP's to Recessed Fixtures

The following information describes the fixtures' voltage, temperature and RP placement requirements necessary to U.L. normal and abnormal tests. In addition, this information outlines requirements to be met for proper usage of Sensata's RP thermal protectors.

U.L. Normal Test Box

For proper testing of RP's the following conditions should be met:

1. The fixture should be tested at the rated wattage and specified voltage. For example, if the fixture is rated 120 VAC, then the output voltage should be set at 120 VAC. In order for the RP to operate properly, voltage requirements must be adhered to. A higher voltage can, in some instances, derate the RP and cause nuisance tripping.
2. The thru wire temperature, if any, should be adhered to.
3. Maximum temperatures allowed by the standard agencies should not be exceeded.
4. The RP is not dependent on orientation. It can be placed in a vertical position.

U.L. Abnormal Test Box

For proper testing of RP's the following conditions should be met:

1. At least 1 inch of insulation should completely surround the RP.
2. The RP should be located approximately two inches from the bottom of the fixture.
3. Only a small amount of epoxy to hold the thermal-couple should be used on the RP.

Proper Usage

The RP functions as an insulation detector, protecting against insulation. The design of the RP thermal protectors allows a specific model to protect a family of fixtures. The operation of the bimetallic device within the RP functions primarily from the biasing of its internal heater. The heater is matched to the supply voltage and generates the majority of the heat necessary to trip the device if it should be completely surrounded by 1 inch of insulation. In this manner, the RP functions as an insulation detector.

For the best performance, the RP-8A thermal protector is typically used for 300 and 500 quartz lamps and 120 Volt 400 Watt HID fixtures where 90°C thru wire is specified. As an alternative to the lower sensitivity RPs, higher sensitivity RPs are commonly used for low wattage fixtures that are listed by UL for mark spacing. This drawing represents the typical placement of these devices for maximum performance:

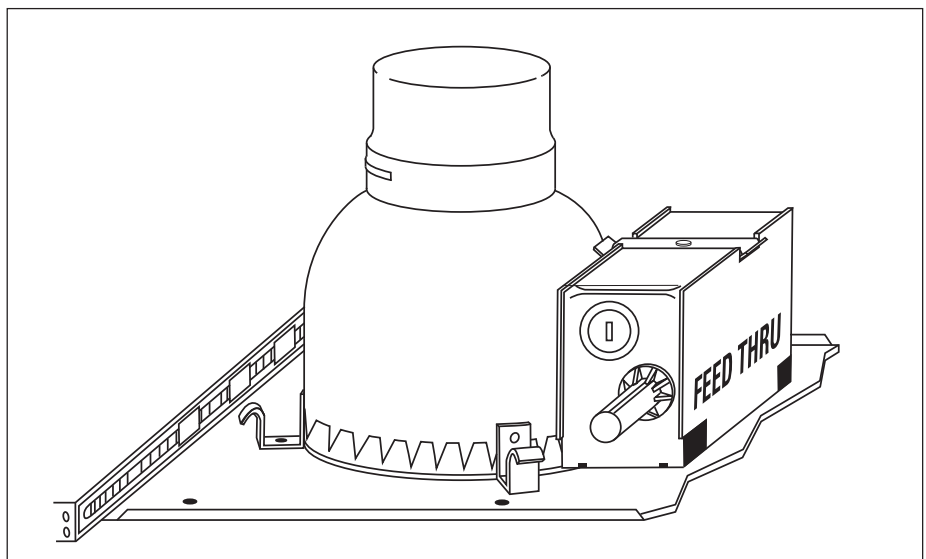

Specifications

The RP and SB600 thermal protector within the RP are recognized and tested under standard UL873 for Temperature Indicating and Regulating Equipment. The thermal protector within the RP was tested by UL for 10,000 cycles to the following values:

1. 500 Watts at 120VAC with tungsten load.
2. 400 Watts at 120VAC to 480VAC with an inductive load.
3. 75 watts at 12VAC with tungsten load.

The RP has passed tests by UL for the City of Chicago for overlamping in the normal test box and air tightness for the return plenum.

The RP clip is made of spring steel and designed for a 7/8" knockout hole to fit a wall thickness of .032-.078".

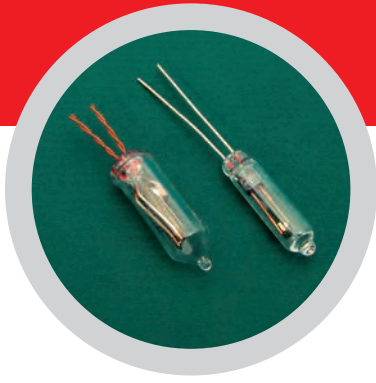

KLIXON | SB/ESB SERIES THERMAL PROTECTORS

WORLD CLASS PERFORMANCE

The SB/ESB Series thermal protector offers the reliability of a bimetal protector in a robust hermetic package. It is ideally suited to provide thermal and/or locked rotor protection in applications requiring unique processing or environmental challenges (AC/DC motors, compressors, transformers, etc.).

With an exceptional history of more than 90 years, Sensata Technologies is a leading supplier of sensors and switches.

Features

- Hermetically sealed
- Compact
- Opening temperature range of 60°C to 170°C in 5°C increments
- Snap action
- Copper or tin plated copper leads in a variety of lengths

Benefits

- Safe from penetration of fluids
- Ultimate corrosion protection
- No secondary insulation needed
- Can operate in high pressure environments
- Improves safety of end product

Sensata Technologies' miniature, glass encapsulated thermal protectors provide both thermal and current overload protection. The SB/ESB family of protectors combines Sensata's bimetal protection technology with a true glass to metal hermetic seal. This ultra-reliable combination can be used for such things as small AC fractional horsepower motors, DC motors, battery chargers, ballasts, NiCad battery packs, transformers and internal protection for compressors. Sensata Technologies is an ISO and TS registered company providing world class quality products.

Test House Approvals

BEAB – EN60730-2-1, EN60730-2-2 Open Motors (BEAB-CRC 0004)
IEC 730-2-4 Compressor Motors
UL Files E37501 & E28135, UL Nos. 547 & 873
UL IEC 730-2-2 Open Motors
CSA File LR 20529, C22.2 Nos. 77 & 24

Dimensional Drawing

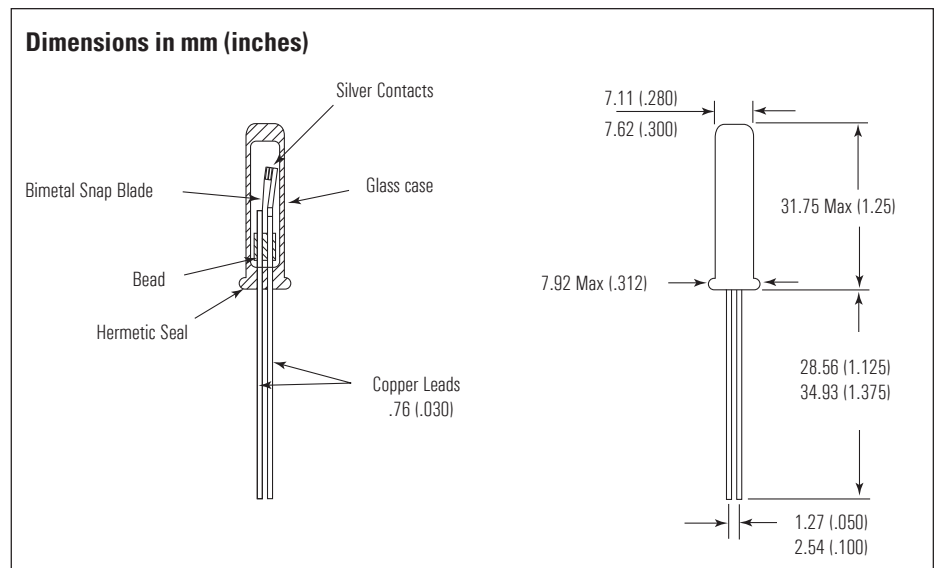

SMALL APPLIANCES INDUSTRIAL & LIGHTING

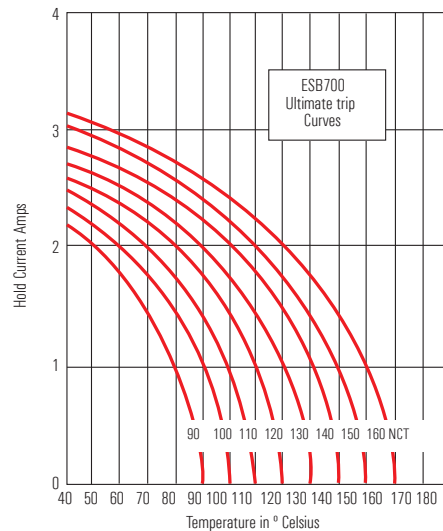
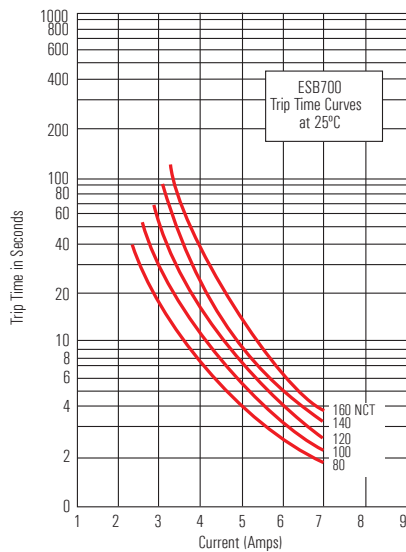
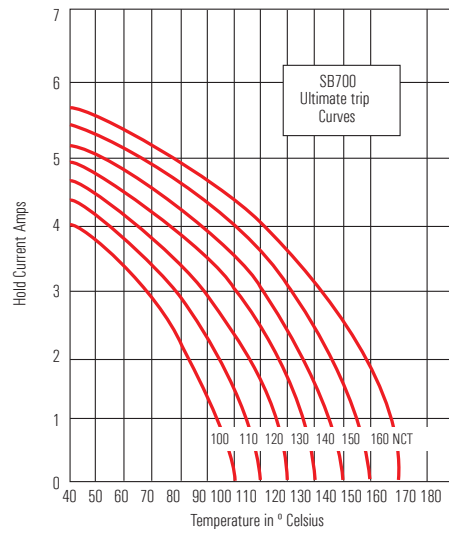
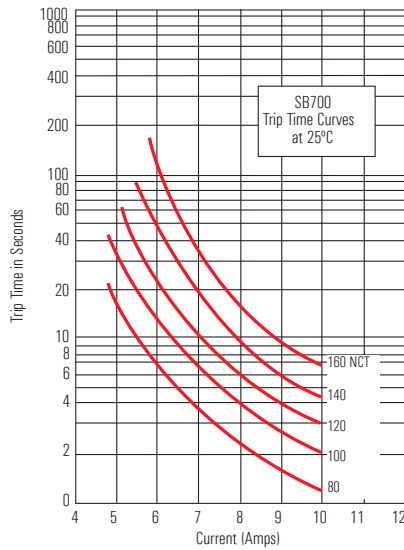
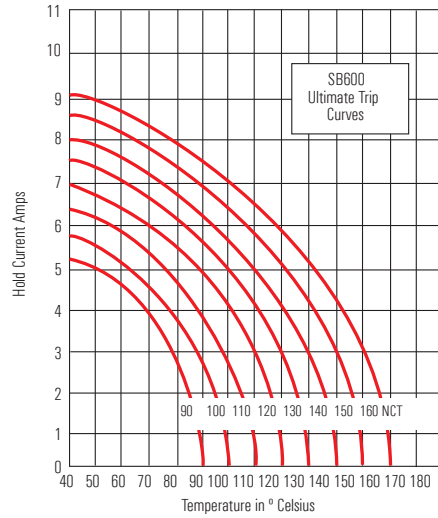
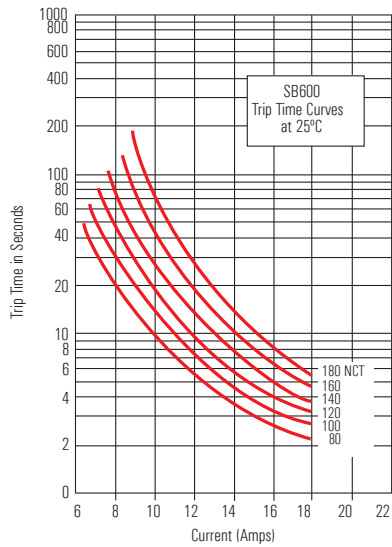

These curves are to be used only as a guide in selecting a protector for a particular application. Factors such as distance from the heat source and the method of mounting should be considered in selecting a protector. Final trip times are dependent upon terminal configuration and mounting in the application.



KLIXON | TH10 THERMAL CUT-OUT

KEY BENEFITS

Flexible mounting:
3 terminal configurations available

Robust design:
The bimetal disc is protected by
the metal support

Full automated live:
Provides stable setting values

Low price:
The particular design provides
high competitiveness

Sensata Technologies has developed the TH10 temperature cut-out to respond to the need of increasing power of heating and personal care appliances. As a result of this, Sensata Technologies has further established its leading position in the worldwide thermal protection market.

Design and operating principles

The TH10 consists of two nickelplated supports, held together with ceramic pins. One support holds the high performance Klixon® bimetal disc, which, in combination with the sophisticated contact system, provides superior cycling performance.

For self-hold versions see TH11/21. A wide temperature range, standard 5K tolerance, different bimetal resistivity, plus optional terminal configurations make the TH10 suitable for a very wide range of applications.

The operating principle of the TH10 is simple and effective. A current flows through the resistive Klixon® bimetal disc. When a fault condition occurs, the increased ambient temperature causes the bimetal disc to snap open the contacts. As the device cools down to a safe temperature again, the contacts will automatically reset.

Applications

The TH10 operates as a sensitive power cut-out for:

- Hair dryers
- Fan heaters
- Convector heaters
- Transformers
- Hand dryers

and various other applications. With the TH10 Sensata Technologies provides you with cost-effective protection while offering superior quality and reliability.

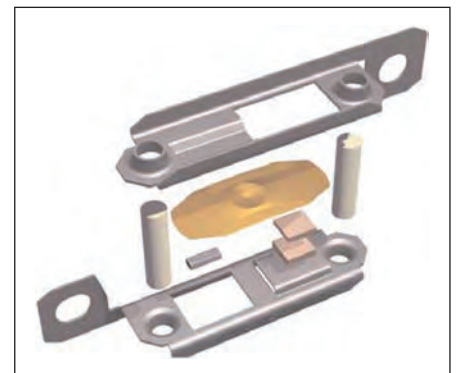

Certifications:

Agency: ENEC

File number: 2014531.14

Rating: 13(2)A 250 Vac @ 30.000 cycles, 30(5)A 250 Vac @ 3.000 cycles

Standard: EN60730-2-9, EN60730-2-2, EN60730-1

Agency: UL

File number: E54813

SMALL APPLIANCES INDUSTRIAL & LIGHTING

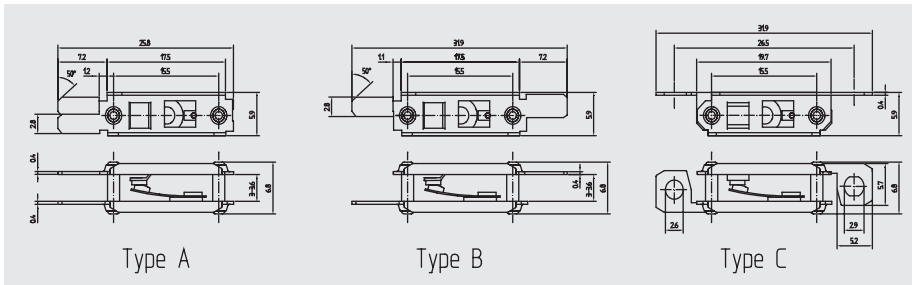

Terminal Configuration		Disc and contact support material		Standard opening temperature		
Code	Terminals	Code	Material	Operating Temp.	Low resistivity bimetal disc (F30)	High resistivity bimetal disc (B1)
A	Terminals on same end	A	Nickel plated steel	60°C	031	035
B	Terminals on opposite end			65°C	041	045
				70°C	051	055
				75°C	061	065
				80°C	071	075
				85°C	081	085
				90°C	091	095
				95°C	101	105
				100°C	111	115
				105°C	121	125
				110°C	131	135
				115°C	141	145
				120°C	151	155
				125°C	161	165
				130°C	171	175
				135°C	181	185
				140°C	191	195
				145°C	201	205
				150°C	211	215
				170°C		255

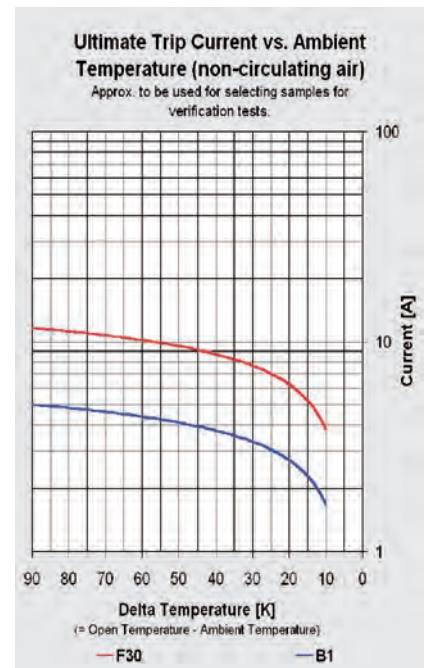

Specifications

Standard operating temperature range	from 45°C - 170°C
Max. Ambient temperature	200°C
Tolerance on open temperature	± 5K

Declarations		Declarations	
Declarations to EN60730-2-9		Declarations to EN60730-2-2	
Purpose of the control	Thermal Cut-Out	Purpose of the control	Thermal Motorprotector
Construction	Incorporated, non-electronic		
Degree of protection	IP00		
Terminals for ext. conductors	For internal conductors only		
Method of (dis) connection of terminals	Riveting, soldering, spotwelding, springloaded contacting		
Details for terminals for internal conductors	Insulation of conductors used by OEM's must be able to withstand the operating temperatures in normal usage		
Temperature limits of the switchhead	200°C		
PTI of insulation materials	PTI 250	PTI of insulation materials	PTI 250
Method of mounting	By various means in conjunction with (holes in) terminals, such that adequate creepage and clearance distances are maintained between live parts and accessible metal parts	Method of mounting	By various means in conjunction with (holes in) terminals, such that adequate creepage and clearance distances are maintained between live parts and accessible metal parts
Operating time	For continuous operation		
Type of action	Type 2B	Type of action	Type 3C
Reset characteristic	Automatic	Reset characteristic	Automatic
Extent of sensing element	Whole control		
Control pollution degree	Degree 2	Control pollution degree	Degree 2



KLIXON | TH11, TH21 SELF-HOLD THERMAL CUT-OUTS

KEY BENEFITS

Flexible mounting:
3 terminal configurations available

Robust design:
The bimetal disc is protected by
the metal support

Full automated live:
Provides stable setting values

Low price:
The particular design provides
high competitiveness

Sensata Technologies has developed the electrical self-hold temperature cut-out in order to offer a nonself resetting device, suitable for high current applications, thus fulfilling the growing need for higher safety.

Design and operating principles

The TH11 and TH21 consists of two nickel-plated supports, held together with ceramic pins. One support holds the high-performance Klixon® bimetal disc, which, in combination with the sophisticated contact system, guarantees the superior cycling performance. One ceramic pin has a layer of resistive material, functioning as a small heater when a voltage is supplied. A wide temperature range, standard 5K tolerance, different bimetal resistivity and various optional terminal configurations make the TH11 and TH21 suitable for a wide range of applications.

Whereas the TH11 operates at 230 Vac. The TH21 is designed for 120 Vac applications. Because of their identical dimensions, the TH11 and TH21 can be easily exchanged with the auto reset thermal protector TH10.

The operating principle of the THseries is both simple and effective. A current flows through the resistive Klixon® bimetal disc. When a fault condition

occurs, the increased ambient temperature causes the bimetal disc to snap open the contacts. The resistive layer spots the voltage over the open contacts and a current flows through the resistor, generating sufficient heat to keep the bimetal warm and the contacts open. When the power is switched off, the device cools down to a safe temperature and the contacts will close.

Applications

The TH11 and TH21 are temperature resistive cut-outs for such applications as:

- Fan heaters
 - Convector heaters
 - Hair dryers
- and various other applications which require a non-self resetting protector like transformers, cable reels etc.



Certifications:

Agency: ENEC

File number: 2014531.14

Rating: 16(2)A 250 Vac @ 1.000 cycles

Standard: EN60730-2-9, EN60730-2-2, EN60730-1

Agency: UL

File number: E54813

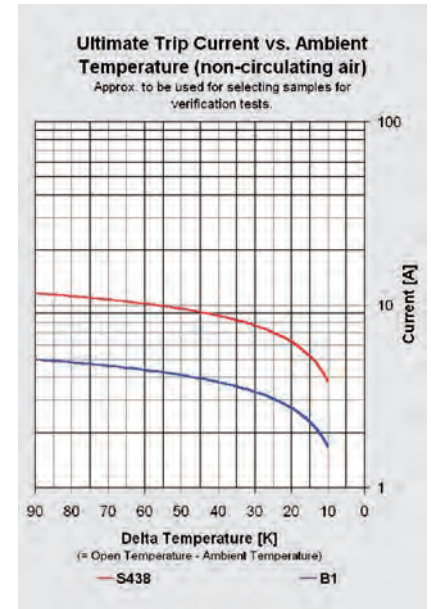
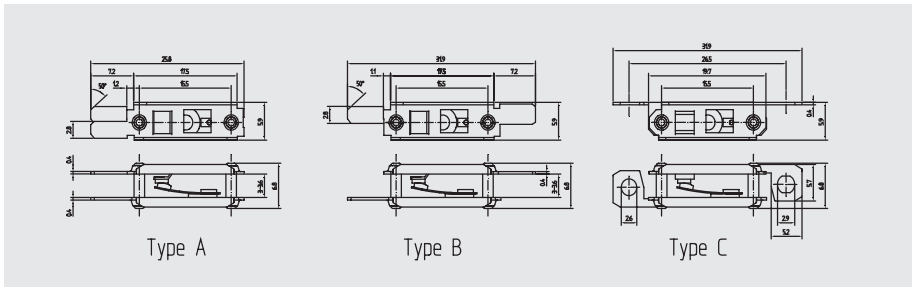

Coding System

TH 11		C		A		101		
Function		Terminal Configuration		Disc and contact support material		Standard opening temperature		
11	220V selfhold	A	Terminals on same end	A	Steel	Operating Temp.	Low resistivity bimetal disc (F30)	High resistivity bimetal disc (B1)
21	110V selfhold	B	Terminals on opposite end			60°C	031	035
		C	Terminals on opposite end (with holes)			65°C	041	045
						70°C	051	055
						75°C	061	065
						80°C	071	075
						85°C	081	085
						90°C	091	095
						95°C	101	105
						100°C	111	115
						105°C	121	125
						110°C	131	135
						115°C	141	145
						120°C	151	155
						125°C	161	165
						130°C	171	175
						135°C	181	
						140°C	191	
						145°C	201	
						150°C	211	

Specifications

Standard operating temperature range	from 60°C - 150°C TH11 from 60°C - 130°C TH21
Max. Ambient temperature	200°C
Tolerance on open temperature	± 5K
Selfhold function in still-air	> -20°C TH11 > -35°C TH21

Declarations TH11

Declarations to EN60730-2-9

Purpose of the control	Voltage maintained Thermal Cut-Out
Construction	Incorporated, non-electronic
Degree of protection	IP00
Terminals for ext. conductors	For internal conductors only
Method of (dis) connection of terminals	Riveting, soldering, spotwelding, spring loaded contacting
Temperature limits of the switchhead	200°C
PTI of insulation materials	PTI 250
Method of mounting	By various means in conjunction with (holes in) terminals such that adequate creepage and clearance distances are maintained between live parts and accessible metal parts
Operating time	For continuous operation
Type of action	Type 2B
Reset characteristic	Voltage maintained off-position thru heat from the heaterfilm on one ceramic pin. Device resets by interrupting the power supply
Extent of sensing element	Whole control
Control pollution degree	Degree 2



KLIXON | YS10 SMALL THERMOSTAT PROTECTOR

KEY BENEFITS

High current capacity (125Vac / 16A) to cut off power circuit

Keep small size as conventional protector MA10, and thermal sensitivity

Reliable long life

Features

YS10 was developed to protect people and property from accidents occurring on products such as Hair Dryer/Fan heater. It is an automatic resettable, incorporated thermal cut-out (Type 2C). The YS10 pursued to enable to be used for higher wattage products, therefore highest current can be loaded through YS10, and directly cut off power line. But the distance of mounting holes is kept at same size as conventional protector MA10.

Construction

YS10 is constructed with only few parts as a simple and open design (IP00) and based on the well known thermostat technology of Texas Instruments.

1.Upper Terminal carries current to 2. Lower Terminal which is insert molded in 3.Lower Block, via 4.Movable Arm, 5.Movable Contact and 6.Stationary Contact. All parts are riveted to hold with 8.Eyelet. Refer drawing

7.Bimetal Disc is placing under 4. Movable Arm to push it up to open Contact, when 7.Bimetal Disc sensed high ambient temperature around YS10. Heat generated by 4.Movable Arm is designed properly on a combination with operation temperature and Trip current. Therefore, user could select best choice of MUST HOLD current for their product.

The YS10 is mounted by various means in conjunction with (holes in) the terminals, such that adequate creepage and clearance distances are maintained between live parts and accessible metal parts. The electrical connections are for internal wiring only and are achieved by

e.g. riveting, soldering or spot welding.

Specification

Contact Capacity:	12(3)A 250Vac, 16(3)A 125Vac,
Temperature Range:	60 to 150°C
Tolerance on Open Temperature:	+/- 5K Max.
Temp. of switch head:	150°C
Operating time:	continuous
Pollution situation:	normal
Extent of sensing element:	whole control

Certifications

UL	E 34618
CSA	24458
ENEC	2014531 / 17
CQC	CQC02002001338
MITI	JET99P No.0229

Dimension

Width 5.6 x Length 31.5 x Height 3.5mm
Distance between each hole: 26.5mm
Hole Diameter : 2.7mm

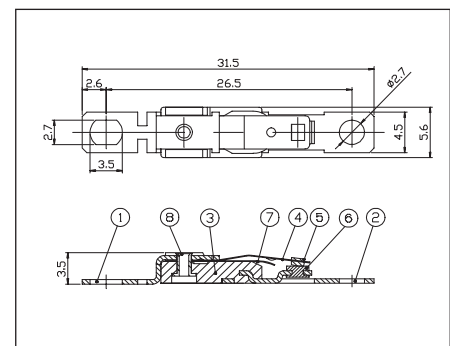

SMALL APPLIANCES INDUSTRIAL & LIGHTING

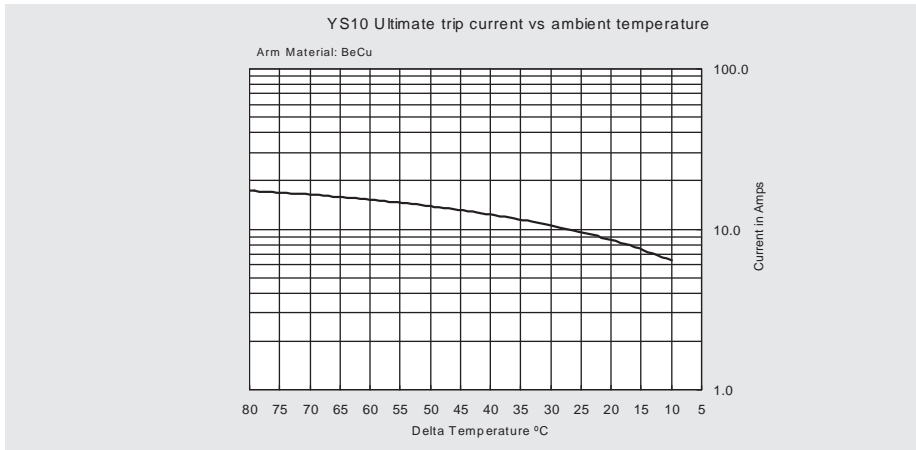

Performance

Ultimate Trip Current Curve:

Small Thermostat Protector Numbering System

It is clearly defined the numbering system to find what user needs to know as follows.

YS10 XXX T (ZZ)

ZZ : Differential for Reset Temperature from Operation Temp.
Blank for standard 30°C differential

T : Termination Identification
S : Standard Terminals (Length 31.5)
A : Both Terminals straight (Length 33.6)
T : PPS Insulator (Length 31.5)
* Standard insulation is applied Vyloglass.

XX : Temperature Code Matrix

Standard Operating Temperature(°C)			
Operating Temperature	Temperature Code	Operating Temperature	Temperature Code
60°C	56	110°C	36
65°C	96	115°C	41
70°C	71	120°C	01
75°C	51	125°C	81
80°C	91	130°C	11
85°C	61	135°C	06
90°C	21	140°C	66
95°C	31	145°C	76
100°C	26	150°C	46
105°C	16		

Y : Movable Arm Identification
A : Titanium Copper C : Nickel Copper
B : Beryllium Copper D : Stainless Steel
Note : BeCu is only certified material for ENEC.

YS10 : Device Identification

Terminal Identification

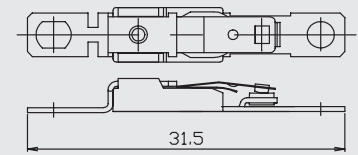

Type S (Standard Configuration)

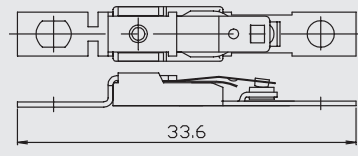

Type A

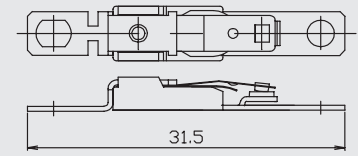

Type T

Example :

YS10 01B-S

120°C operation temperature,
BeCu Movable Arm, Standard
Terminals and 30°C differential.
(90°C reset)



KLIXON | YS11 SMALL THERMAL MOTOR PROTECTOR / THERMAL CUT-OUT

KEY BENEFITS

Plastic Case featured small protector.

Stable and Reliable long life on Non-Current Carry designed device.

Chattering free and precise operating temperature

Features

YS11 was developed to protect people and property from accidents occurring on Motor which is used for Fan motor, washing machine and so on. It functions as a selfresetting thermal cut-out (Type 2B), thermal motor protector (Type 3C) and thermal protector for ballasts. The YS11 pursued to enable to be used for both of installation manner of on-winding and outside of resin packed motor by clamping or insertion. It directly cut off power line. Since it has plastic case, it does not need to insulate YS11 protector from metal parts of motor.

Construction

YS11 is constructed with simple design and based on the well known thermostat technology of Sensata Technologies. And it has enough sealing capability to withstand varnish process and reinforced case enabled to be laced on winding.

7.Movable Arm carries current from 1.Lead to 9.Lower Terminal which is insert molded in 6.Lower Block, via

Dimension

Standard type Case : Width 6.9 x Length 21.5 x Height 4.0mm excluding leads.

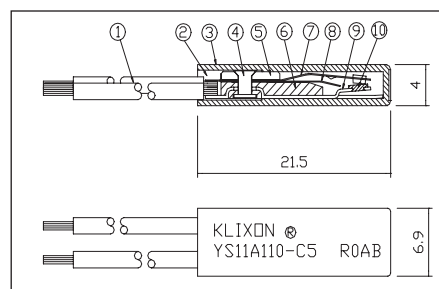

10.Movable Contact and Stationary Contact. 7.Movable Arm, 8.Bimetal Disc and 5.Upper Plate are riveted to secure with 6.Lower Block by 4.Eyelet. This assembly is inserted into 3.Case, and potting Epoxy to seal.

Since trip time to cut off the power is depending on the operation temperature of YS11 protector. Rating should be selected properly. With referring Performance curve, it can be enabled to select best one which is matching with Motor.

Application Notes

R-type case was developed for Resin Packed Motor. This is designed to resist for high pressure which may be loaded during molding process. Maximum pressure is required to be control within 7.5Mpa. Please be noted that R-type case does not have enough sealing capability, therefore it should not applied for winding varnish process. Dimension is 6.0mm x 7.8mm (ellipse) x 23.0mm length.

No	Part Description	Material
①	Leads	Refer Numbering System
②	Epoxy	
③	Case	PBT or PPS
④	Eyelet	Brass
⑤	Upper Plate	Brass
⑥	Lower Block	PBT
⑦	Movable Arm	Refer Numbering System
⑧	Bimetal Disc	
⑨	Lower Terminal	Brass
⑩	Stationary Contact	AgNi alloy

S-Type Case is for use in higher ambient temperature and same configuration as standard case. Housing material is used PPS (RTI:240°C) which is same as R-type case, so that it can resist high temperature for short time. This case is not guaranteed for varnish process as well.

Rating should be selected as properly to protect Motors and other equipment. Short time trip current and Time is described in “Performance” page which helps to choice most adequate operating temperature. Must hold current is also one of important performances, it can be selected from UTC performance curve as well.

Specification:

Contact Capacity :	TCO,TMP	7A/250Vac, 10A/125Vac
	TCO	6A/24Vdc, 15A/18Vdc
	Ballast	2A/250Vac
Temperature Range :		
-Motor Protector and Temp control		45 to 150°C
-Ballast protection		45 to 150°C
Tolerance on Open Temperature:		+/- 5K
Max. temp. of the switch head:		150°C
Operating time:		continuous
Pollution situation:		Dirty
Extent of sensing element:		whole control
Degree of protection		IP00
Electrical connections		soldering, welding

Certifications

UL	E15962 for Motor Protector E34618 for Temp Indicating & Regulating
ENEC	2014531.17 for thermal cut-out, -motor and -ballast protector
CQC:	CQC02002001340/CQC02002001341 -Protectors are not applied in CCC(China Compulsory Certification) at present. So YS11 can not have CCC but CQC. CQC(China Quality Certification Centre) is a national certification body for appliance in China.

Performance

Short time trip performance and Ultimate trip current as reference.

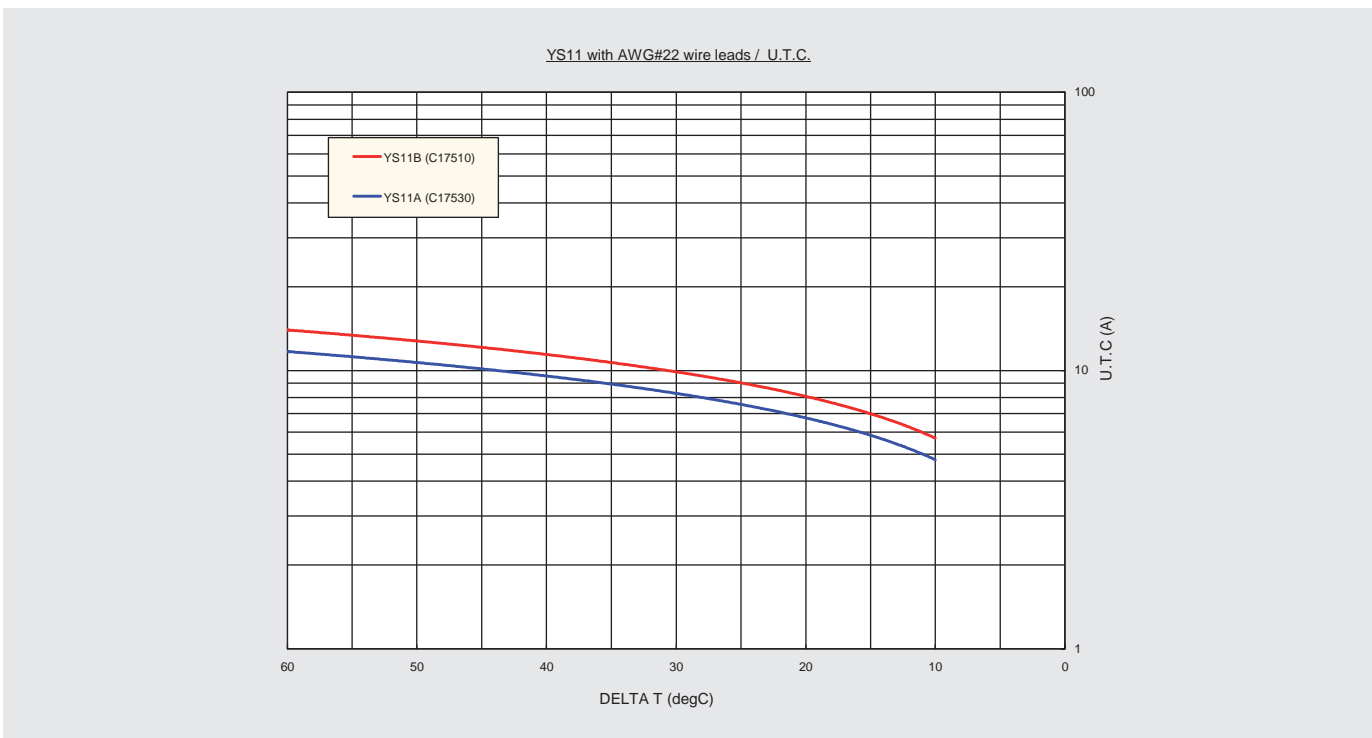
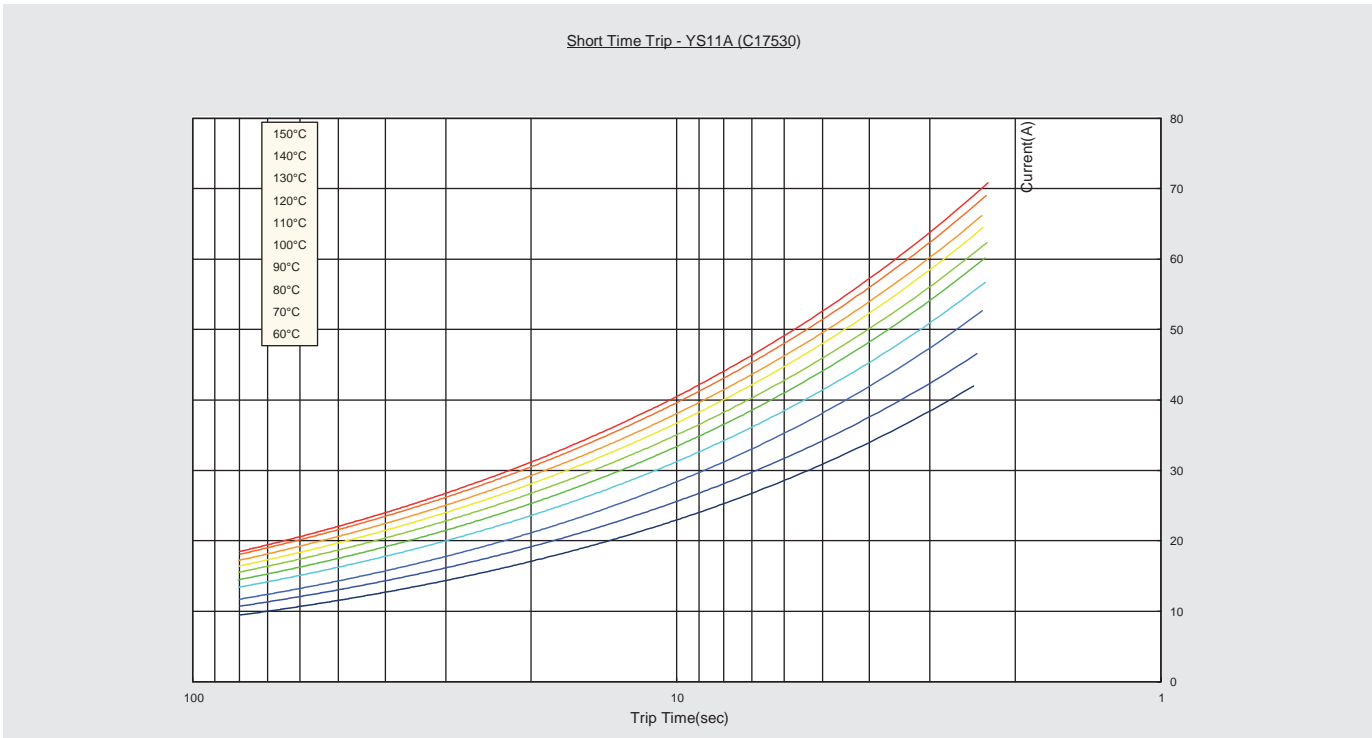

SMALL APPLIANCES INDUSTRIAL & LIGHTING

Numbering System

It is clearly defined the numbering system to find what user needs to know as follows.

YS11 X YYYY - ZW(ZZZ) - (V)

- (V): Other options
- Omitt: No option
- R: Reinforced Case
- S: PPS Case
- T: Groove contact(For DC rating only)
- U: Groove contact and CDA C19220 for lower terminal(For DC rating)

YYYY :

YYY : Open temperature Code

T : Close temperature Code

Temperature Code Matrix

YYY		T	
Code	Open °C	Close °C *1	
		A	B
45 *2	45	>35	>35
50 *2	50	>35	>35
55 *2	55	>35	>35
60 *2	60	>35	>35
65 *2	65	>35	>35
70	70	40	40
75	75	45	45
80	80	50	50
85	85	55	55
90	90	59	60
95	95	62	65
100	100	64	70
105	105	67	75
110	110	70	80
115	115	73	85
120	120	76	90
125	125	79	95
130	130	83	100
135	135	86	105
140	140	90	110
145	145	94	115
150	150	96	120

*1 Close temperature for reference

*2 A is for Snap Open/Close guarntted.

B is for snap open guarntted.

ZW(ZZZ): Optional Leads material, length and else.

Z : Leads material can be selected from table below

as standard rating,

A : UL style 3266 AWG22 Tin coated-BL

B : UL style 1430 AWG22-WH

C : UL style 3398 AWG22 Tin coated-YL(Kurabe)

D : UL style 3398 AWG22-YL(Kurabe)

E : UL style 3266 AWG22-BK

F : Copper Solid Wire D=0.8mm

G : UL style 3266 AWG22 Tin coated-WH

W : Leads length can be selected from Table below as standard rating.

5mm Strip		10mm Strip	
W	Length	W	Length
1	25	11	25
2	30	12	30
3	35	13	35
4	40	14	40
5	45	15	45
6	50	16	50
7	55	17	55
8	60	18	60
9	65	19	65
10	70	20	70

(ZZZ) : Other than above standard combination, 2 or 3 digits of number or letter is assigned as customized one.

X : Performance Identification

Code	Arm Material
A	BeCu C17530
B	BeCu C17510

YS11 : Device Identification

Example :

YS11A130B-C7

YS11 with C17530 material Movable Arm.

130 °C open, 100 Close temperature.

UL 3398 AWG22 55mm length leads

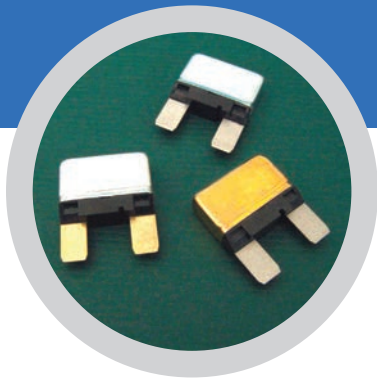

KLIXON | Maxi Breaker™ SERIES CIRCUIT BREAKERS

WORLD CLASS PERFORMANCE

The Maxi Breaker is ideally suited for underhood applications where ambient conditions can reach 125°C. Both SAE Type 1 and Type 2 Maxi Breakers are available in ratings up to 50 amps.

With an exceptional history of more than 90 years, Sensata Technologies is a leading supplier of sensors and switches.

Features

- Available in SAE Type 1 (cycling) and SAE Type 2 (non-cycling)
- Multiple bimetallic resistivities available
- Heater wire wrapped around the bimetal keeps the protector open until power is removed (Type 2 only)

Benefits

- Insensitive to momentary overloads
- Self-resetting characteristics add safety to critical areas of protection
- Accommodates longer life cycle requirements
- Ambient compensated design allows for use in harsh areas where temperatures may reach 125°C

Sensata Technologies' Maxi Breaker Series of circuit protectors are rated for use up to 125°C. This patented device is available both as a cycling (SAE Type 1) and non-cycling (SAE Type 2) device. Typical placement of the Maxi Breaker is under the hood fuse blocks or other areas of the vehicle that house a Maxi Blade Fuse*. The Maxi Breaker protects against momentary overloads and eliminates the need for fuse replacement.

Sensata Technologies is an ISO and TS registered company providing world class quality products.

Dimensional Drawing

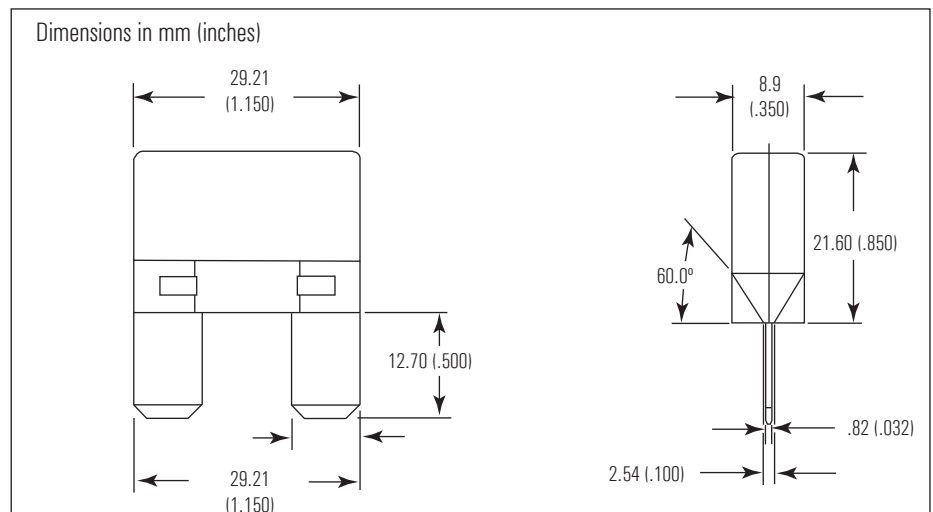

AUTOMOTIVE ELECTRICAL PROTECTION

General Specifications

Nominal Operating Voltage	14 Volts DC
Typical Voltage Drop at Operating Current	200 mV max.
Current Rating.....	10 to 50 amps at 25°C (in 5 amp increments)
Typical Ambient Temperature Range	-40°C to 125°C

These curves are to be used only as a guide in selecting a protector for a particular application. Factors such as distance from the heat source and the method of mounting should be considered in selecting a protector. Final trip times are dependent upon terminal configuration and mounting in the application.

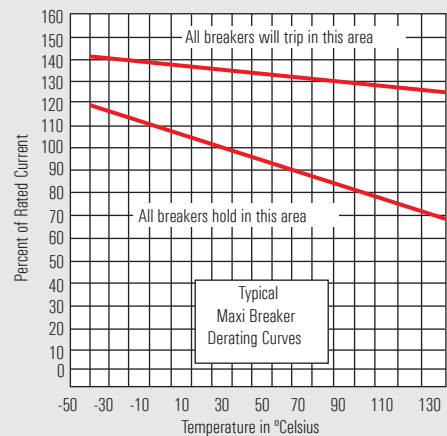
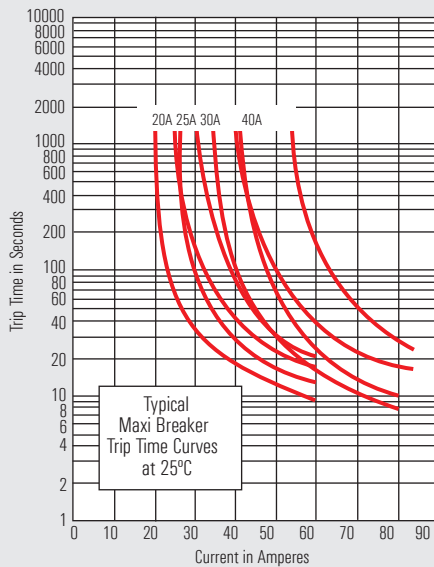

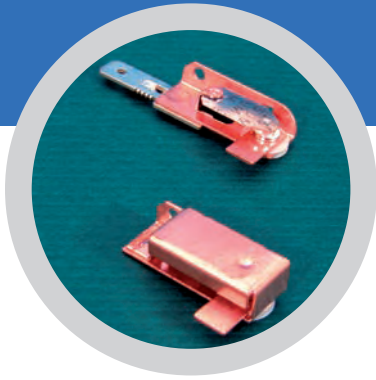

KLIXON | SMB SERIES DC MOTOR PROTECTORS

WORLD CLASS PERFORMANCE

The SMB Series is a high current DC motor protector which delivers the benefit of locked rotor and overload protection in a robust integrated package.

With an exceptional history of more than 90 years, Sensata Technologies is a leading supplier of sensors and switches.

Features

- Copper plated steel base and tab
- Available in covered and uncovered versions
- Designed to trip time or temperature specifications
- Multiple bimetallic resistivities available
- 100% compliance with the Substance of Concern (SoC), ELV and RoHS hazardous material initiatives

Benefits

- Electrical connection enabled by soldering, riveting, or resistance welding
- Snap action device provides longer life cycle
- Brush card or end cap mountable in the motor
- Multiple lug and brush/bracket optionstures may reach 125°C

Sensata Technologies' SMB Series of snap action motor protectors are designed for DC blower and engine

cooling fan motors, pump motors or other applications up to 42 Volts where over-current or over-temperature protection are required. The SMB is equipped for operation under harsh temperature extremes.

A broad range of design and mounting options enable this device to be custom engineered to meet your needs.

Sensata Technologies is an ISO and TS registered company providing world class quality products.

Dimensional Drawing

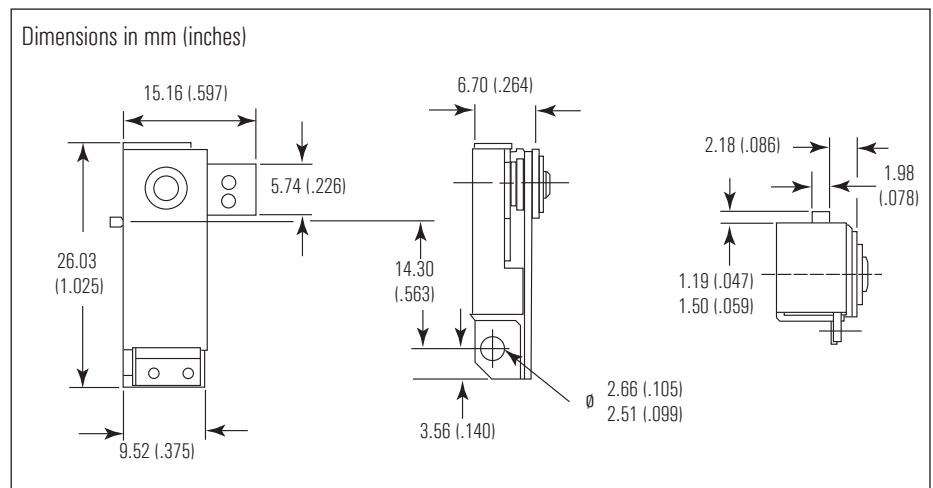

AUTOMOTIVE ELECTRICAL PROTECTION

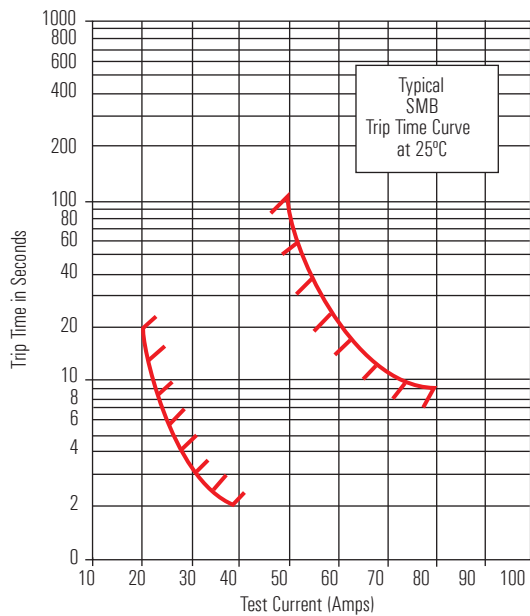

General Specifications

Nominal Operating Voltage	12-24 Volts DC
Typical Voltage Drop at Operating Current	200 mV max.
Typical ambient temperature range	-40°C to 110°C
Maximum Operating Current.....	35 Amps
Peak Room Temperature Stall Current.....	>100 Amps

These curves are to be used only as a guide in selecting a protector for a particular application. Factors such as distance from the heat source and the method of mounting should be considered in selecting a protector. Final trip times are dependent upon terminal configuration and mounting in the application.

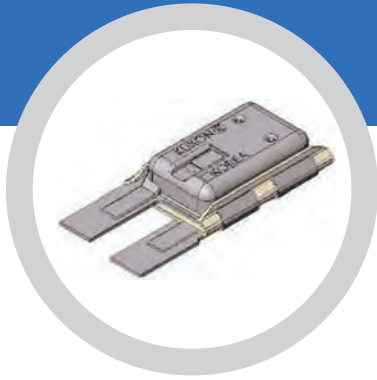

KLIXON | 5AP MOTOR PROTECTOR

KEY BENEFITS

Thermal motor protection reacting to both current and temperature

Wide variety of standard terminal configurations

Terminal material provides trouble-free welding

Eligible for customer partnumber printed on product as well as color-coding

Varying of both bimetal and S-wire resistivity creates a current-time characteristic optimized for each specific application

Unique combination of bimetal disc and resistivity wire guarantees very precise tripping times thus prevents too high motor temperature

Protector selection and application testing by Sensata Technologies laboratory with results in extended report at your service

As a world leader in automotive motor protection, Sensata Technologies has developed the smallest bimetal based protection available at the market today, the 5AP. The 5AP is developed to operate in wide temperature and current ranges, while providing consistent performance characteristics and excellent reliability. CAD-based design techniques combined with 6-Sigma supported manufacturing lines and the best quality control systems give this product maximum safety and reliability. The 5AP operates as a sensitive power cut-out which is widely used in Window-Lifts, Adjuster-Motors, Door-Locks and various other applications. One protector series covers a broad range of applications, thus providing the flexibility to customize a particular rating based on the specific requirements of universal applications. But let's find out what really makes the 5AP perform its job as it does: the Sensata Klixon® control.

Klixon® snap-action controls

The Klixon® disc is made of a combination of different metals with a predetermined calibration point. When heated, one of the metals expands more than the other, causing the disc to snap. As a world leader in bimetal technology and bimetal-based devices, Sensata Technologies has set its goals of constant improvement and maximum reliability during years of operation and thousands of cycles.

Design and operating principles

The 5AP is manufactured on fully automatic equipment, custom designed to meet the various requirements of today's automotive industry. As a world leader in automotive motor protection, Sensata Technologies has developed the smallest

bimetal based protection available at the market today, the 5AP. The 5AP is developed to operate in wide temperature and current ranges, while providing consistent performance characteristics and excellent reliability. CAD-based design techniques combined with 6-Sigma supported manufacturing lines and the best quality control systems give this product maximum safety and reliability. The 5AP operates as a sensitive power cut-out which is widely used in Window-Lifts, Adjuster-Motors, Door-Locks and various other applications. One protector series covers a broad range of applications, thus providing the flexibility to customize a particular rating based on the specific requirements of universal applications.

Serving the customer

Just provide us with your specifications concerning specific current and temperature conditions and we will select a matching 5AP motor protector and provide you with samples. But we do more than that. A skilled staff is available to perform application testing and protector selection in a well equipped laboratory with sophisticated, state-of-the-art equipment, located at each region. In close cooperation with the customer we develop the optimum solution, providing the lowest cost of ownership and thus increasing your competitive advantage. If motor testing and assembly are required on a larger scale, pilot series for your verification will be supplied within a very short cycle time. With design cycles becoming shorter and shorter, you can expect our prompt reply. If you wish to select your own ratings we have a software tool available to assist you in making the right selection. 5AP production facility is located in Asia.

AUTOMOTIVE ELECTRICAL PROTECTION

Standard Terminal Configurations

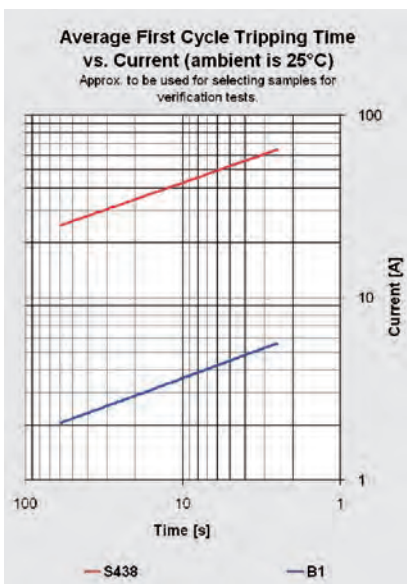
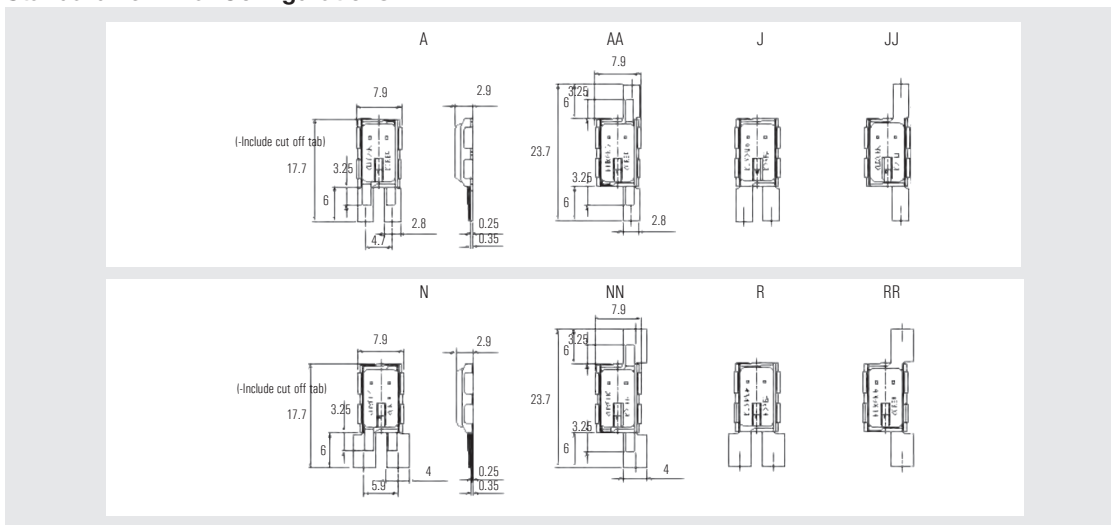

The curves of First Cycle Tripping time and Ultimate trip current are meant to be for selecting samples to perform verification tests only. In the figures two curves of a wide range of possibilities are shown. The level and slope can be varied by making another selection for the pre-set temperature, bimetal disc and/or heater.

Maximum contact rating
15 Vdc / 27A / 30.000 cycles

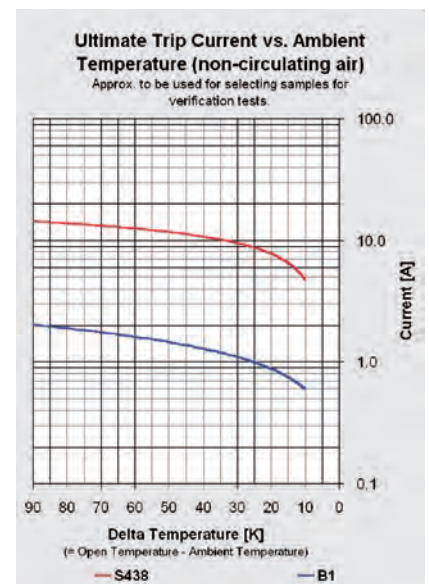

Specifications

Standard operating temperature range	from 100°C - 170°C (Increments 5K)
Tolerance on open temperature	± 5K
Peak temperature (5 min)	200°C
Max. Ambient temperature	T-open +20°C
Time check at T-ambient 25°C	4 to 10 seconds



KLIXON | 6AP MOTOR PROTECTOR

KEY BENEFITS

Thermal motor protection reacting to both current and temperature

Wide variety of standard terminal configurations

Terminal material provides trouble-free welding and in pre-tinned variation easy wavebath-soldering

Eligible for customer partnumber printed on product as well as color-coding

Varying of both bimetal and S-wire resistivity creates a current-time characteristic optimized for each specific application

Unique combination of bimetal disc and resistivity wire guarantees very precise tripping times thus prevents too high motor temperature

Protector selection and application testing by Sensata Technologies laboratory with results in extended report at your service

As a world leader in automotive motor protection, Sensata Technologies has developed the 6AP to operate in wide temperature and current ranges, while providing consistent performance characteristics and excellent reliability. CAD-based design techniques combined with 6-Sigma supported manufacturing lines and the best quality control systems give this product maximum safety and reliability. The 6AP operates as a sensitive power cut-out which is widely used in Window-Lifts, Adjuster-Motors, Wipers, Door-Locks and various other applications. One protector series covers a broad range of applications, thus providing the flexibility to customize a particular rating based on the specific requirements of universal applications. But let's find out what really makes the 6AP perform its job as it does: the Sensata Klixon® control.

Klixon® snap-action controls

The Klixon® disc is made of a combination of different metals with a pre-determined calibration point. When heated, one of the metals expands more than the other, causing the disc to snap. As a world leader in bimetal technology and bimetal-based devices, Sensata Technologies has set its goals of constant improvement and maximum reliability during years of operation and thousands of cycles. These high quality standards also explain the impressive production of several hundreds of millions of Sensata Klixon® controls annually.

Design and operating principles

The 6AP is manufactured on fully automatic equipment, custom-designed to meet the various requirements of

today's automotive industry. The compact 6AP metal housing with integrated terminal holds the pre-set Klixon® snap-action bimetal disc. The split plate carries a resistive S-shaped wire which provides additional current sensitivity. The advanced contact system - one on the bimetal disc and one on the plate - in combination with the strong disc guarantees a long life and reliable cycling. The operating principle of the 6AP is both simple and effective. The protector is actuated by current passing through and by heat received from the ambient temperature. The electrical circuit is interrupted when the disc reaches its preset temperature. As the device cools down to a safe temperature again, the contacts automatically reset. Each 6AP temperature rating has a bimetal disc specifically manufactured for that rating. Each device is calibrated and checked for opening-temperature. This results in optimum characteristics and consistent performance over the required life.

Serving the customer

Just provide us with your specifications concerning specific current and temperature rise conditions and we will select a matching 6AP motor protector and provide you with samples. But we do more than that. A skilled staff is available to perform application testing and protector selection in a well-equipped laboratory with sophisticated, state-of-the-art equipment. In close cooperation with the customer we develop the optimum solution, providing the lowest cost of ownership and thus increasing your competitive advantage. If motor testing and assembly are required on a larger scale, pilot series for your verification

AUTOMOTIVE ELECTRICAL PROTECTION

will be supplied within a very short cycle time. With design cycles becoming shorter and shorter, you can expect our prompt reply. If you wish to select your own ratings we have a software tool

available to assist you in making the right selection.

6AP production facilities are located in Asia and Europe.

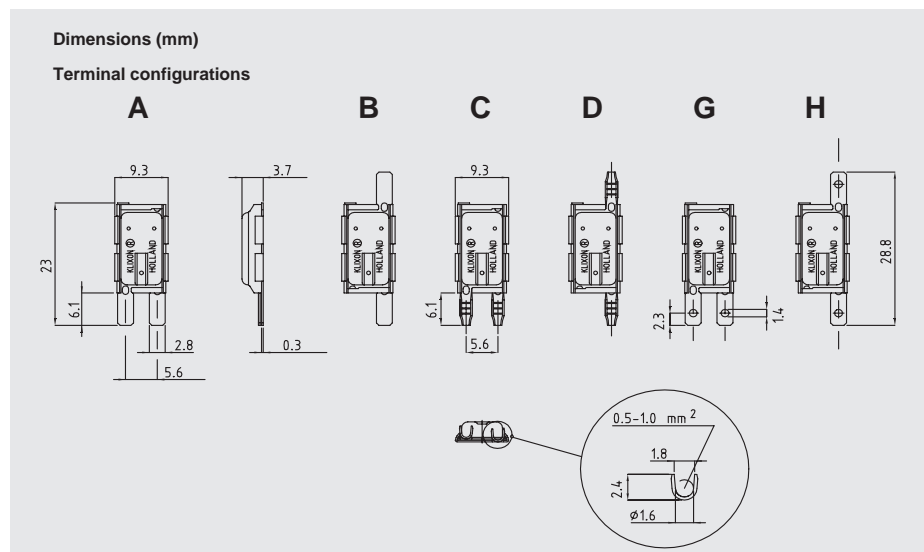

The curves of First Cycle Tripping time and Ultimate trip current are meant to be for selecting samples to perform verification tests only. In the figures two curves of a wide range of possibilities are shown. The level and slope can be varied by making an other selection for the pre-set temperature, bimetal disc and/or heater.

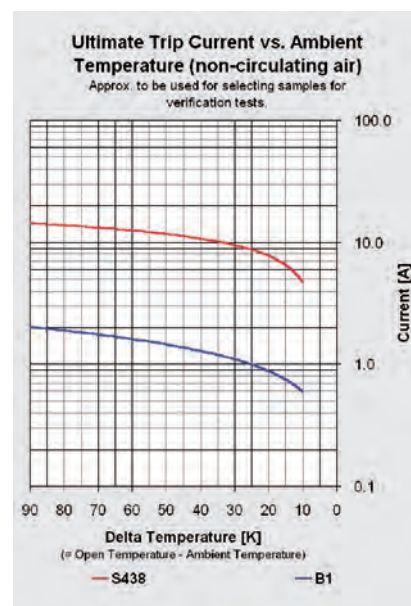
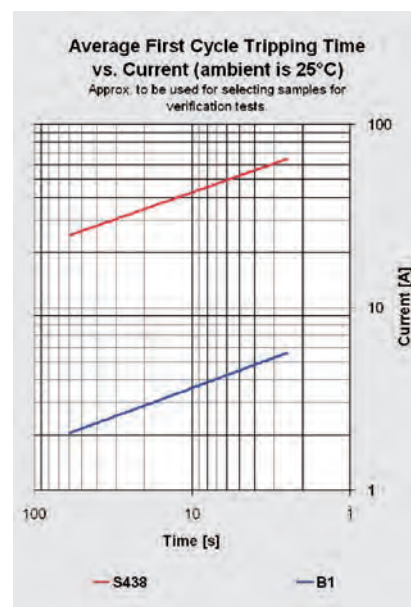

Specifications

Standard operating temperature range	from 100°C - 170°C (Increments 5K)
Tolerance on open temperature	± 5K
Peak temperature (5 min)	200°C
Max. Ambient temperature	T-open +20°C
Time check at T-ambient 25°C	4 to 10 seconds depending on current level

Maximum contact rating

15 Vdc / 30A / 30.000 cycles
30 Vdc / 15A / 30.000 cycles

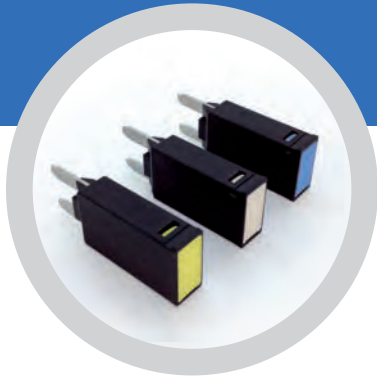

KLIXON | MINI 100 CIRCUIT BREAKER

KEY BENEFITS

Ratings up to 30 amps
with a color tap cover

Protection device to guard
against momentary overloads

Bimetallic device is sensitive
to both over-current and over-
temperature fault conditions

Secondary Circuit Protection

The MINI 100 Series circuit breaker is designed as a drop-in replacement for mini type fuses for use in critical safety circuits, or where an automatic resettable protection is needed. The MINI 100 is available in ratings up to 30 amps with a color tap cover.

With an exceptional a history of more than 90 years, Sensata Technologies is leading supplier of sensors and bimetal switches

Overview

Sensata Technologies MINI 100 Footprint Series of circuit breakers are designed for wiring harness protection in 12V/24V DC automotive, agriculture, marine, and robotic applications. The MINI 100 is an ideal protection device to guard against momentary overloads. The MINI 100 can be mounted in a 280 and/or ATM footprints also known as MINI mini-fuse location. Optional mounting needs can be addressed by contacting Sensata Technologies. This bimetallic device is sensitive to both

over-current and over-temperature fault conditions. This device is especially designed with a Secondary Circuit Protection that uses a fusible link as backup protection for end of life failure modes of the device. Sensata Technologies is an ISO and QS registered company providing world-class quality products.

Benefits

- Includes an internal Secondary Current Protection(SCP) option
- The SCP is designed for short circuit protection similar to a fusible link with the benefit of a resettable circuit breaker feature.
- 24V and SAE Type 3 versions under development. Contact Sensata Technologies for further information.
- Includes a robust plastic design cover with optional cap colors for easy part identification
- Cooler terminal and cover temperature design
- Exceeds SAE J553 requirements

Example: Mini 120-2SA Current re-rating with ambient temperature

NOMINAL CURRENT RATING (A)	Color Coding	DE-RATED CURRENTS @ AMBIENT TEMPERATURES		
	Top cap Cover	-40°C	25°C	85°C
5	Tan	6.25	5	3.5
7.5	Brown	9.4	7.5	5.25
10	Red	12.5	10	7
15	Blue	18.7	15	10.5
20	Yellow	25	20	14
25	White	31	25	17.5
30	Green	34	30	21

AUTOMOTIVE ELECTRICAL PROTECTION

Configuration

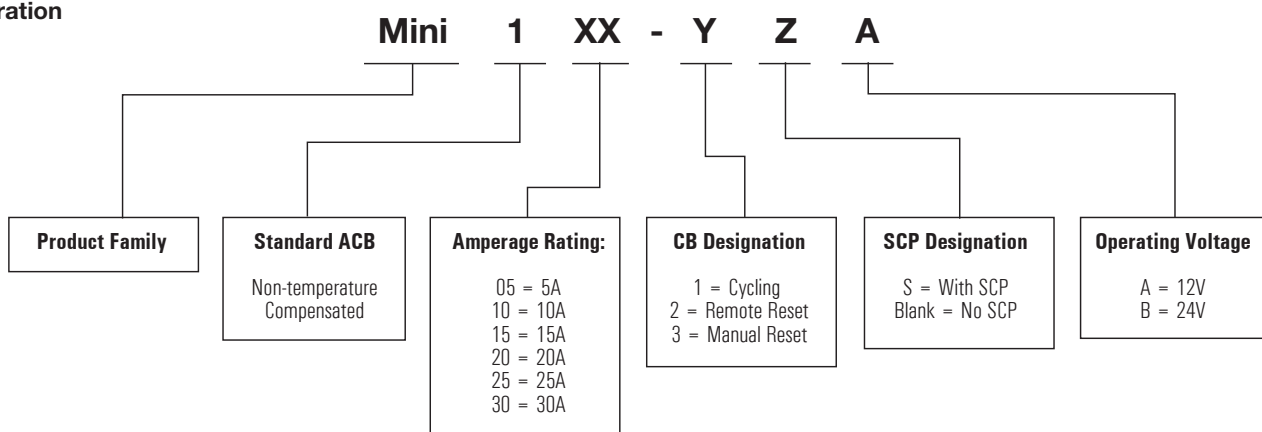

Y-Configuration: Type 1(cycling), Type 2(non-cycling) and Type 3(Manual reset).

Specifications





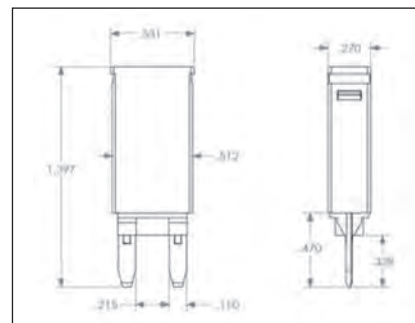
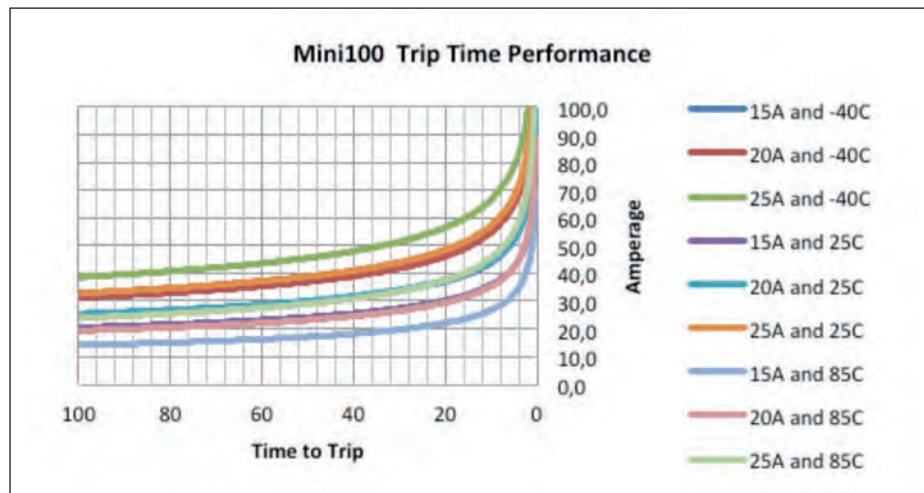





Nominal Operating Voltage..... DC 14V*, DC 24V
 Voltage Drop at Operating current..... 150 mV max
 Nominal Current Rating..... 5 to 30 amps @ 25 C
 Operational Temperature Range..... 40°C to 85°C (nominal temperature of 25°C)
 Polarity..... Independent of circuit polarity

*The circuit breaker must operate within the range of 9.0 to 16.0 Volts DC. Nominal intended voltage is 14.0 volts DC. Unless otherwise specified, testing by customers should be conducted at 14V DC.



This chart only shows trip time performance for 15A-25A. For other current ranges please contact Sensata Technologies. These curves are to be used only as a guide in selecting a protector for a particular application. Final trip times are dependent upon the type of application and are the responsibility of the application engineer to determine through appropriate testing

KLIXON | GENERAL ST THERMOSTAT PORTFOLIO

Product	PHOTO	Description	Key Applications & Segments
4344 (1822)		Basic 1/2 inch hermetic thermostat	Aircraft, marine, rail/transit, military, medical, semiconductor, industrial
6786		Low profile thermostat for high shock and vibration applications	Military, aerospace
7BT		Phenolic non-hermetic thermostat (customized 1NT)	Industrial, Rail/transit
M1 (11041)		4344 with flat washer instead of wave washer, backfilled with NO2	Military, aerospace
M24236/1		M1 tested to MIL-PRF-24236/1 Group A with Group B test results on file	Military, aerospace
3BT		Military grade Tiny Stat (hermetic)	Military, aerospace
4BT		Military grade Tiny Stat (hermetic)	Military, aerospace
5BT		Military grade 1/2 inch thermostat (hermetic) - SPDT	Military, aerospace
M2		Military grade narrow differential hermetic thermostat	Military, aerospace
4391		Highest capacity thermostat with overmold option	Aerospace, Rail/transit
6600		Bi-metal thermostat in 8 pin DIP package for circuit board protection	PCB protection for aircraft, automotive, computer, and test equipment applications

Temp Range (deg F)	Max Load @ 120VAC	Switch Action	Differential (deg F)	UL Recognition	Military Spec
-65 to 550	7 A	SPST	20 to 70	UL/CSA	
-20 to 350	7 A	SPST	20 to 40	UL/CSA	MIL-STD-202
30 to 350	15 A	SPST	20 to 40	UL/CSA	
-65 to 550	7 A	SPST	20 to 70		MIL-STD-202
-65 to 550	7 A	SPST	20 to 70		MIL-PRF-24236/1
0 to 350	1 A	SPST	30		MIL-PRF-24236/19
0 to 350	1 A	SPST	30		MIL-PRF-24236/13
-65 to 400	3 A	SPDT	20 to 35		MIL-PRF-24236/24
0 to 300	2 A	SPST	2 to 7		MIL-PRF-24236/20
-65 to 450	14 A	SPST or SPDT	15 to 60		
104 to 266	1 A	SPST	39 to 48	E36687	N/A

KLIXON | GENERAL ST THERMOSTAT PORTFOLIO CONTINUED

6700		Bi-metal thermostat in TO-220 package for circuit board protection	PCB protection for power supplies, aircraft, automotive, and medical equipment
5003		Half inch non-hermetic low profile bi-metal thermostat	
5004		Half inch non-hermetic high current bi-metal thermostat	Office machines, radar, computer peripherals, industrial heater blankets
5011		Half inch hermetic bi-metal thermostat	
4100		Half inch brass probe thermostat	Liquid bath control, hydraulic systems, degreasers, air compressors
5020		Half inch hermetic brass probe thermostat	
20413, 20600, 20650		Bi-metal 3/4 inch non-hermetic thermostat (auto and manual reset)	Air-conditioners, HVAC Equip, vending machines, clothes dryers, tabletop appliances
20490, 20491, 20492, 20493		Bi-metal 1 inch non-hermetic thermostat (auto and manual reset)	Electric heaters, clothes dryers, water heaters, washing machines, dishwashers
20425		Bi-metal non-hermetic automatic reset thermostat	Commercial refrigeration, air-conditioning, heat pumps
1NT		Half inch non-hermetic thermostat (auto and manual reset)	Furnaces, gas boilers, diesel fuel heaters, tabletop appliances
3NT		Half inch non-hermetic thermostat (auto reset)	Commercial refrigeration, heat pumps, de-humidifiers, ice makers

104 to 266	1 A	SPST	39 to 48	E36687	N/A
35 to 325	5 A	SPST	15 to 30		N/A
35 to 325	15 A	SPST	15 to 30		N/A
140 to 480	3 A	SPST	25 to 40		N/A
104 to 266	1 A	SPST			N/A
35 to 480	3 A	SPST	20 to 40		N/A
-10 to 350	48 A	SPST or SPDT		E9977	N/A
0 to 300	60 A	DPST		MP986	N/A
-10 to 220	25 A	SPST or SPDT		SA995	N/A
0 to 400	15 A	SPST		E9977	N/A
0 to 275	10 A	SPST		SA995	N/A





