



**Sensata**  
Technologies

**KLIXON**<sup>®</sup>

**THERMAL CIRCUIT BREAKERS**



**N** Neumüller  
Elektronik GmbH

Autorisierter Distributor:

Neumüller Elektronik GmbH | Gewerbegebiet Ost 7 | D-91085 Weisendorf  
Tel. +49 9135 73666-0 | [info@neumueller.com](mailto:info@neumueller.com) | [www.neumueller.com](http://www.neumueller.com)

## KLIXON® Thermal Circuit Breakers

KLIXON® thermal circuit breakers are compact, lightweight, protective devices designed to repeatedly interrupt short circuits or extended overloads in applications which require precise, dependable operation plus high resistance to shock and vibration. To avoid nuisance tripping caused by harmless transient or momentary overloads, these circuit breakers feature an inherent thermal time-lag characteristic. This enables equipment to operate at maximum limits with complete safety.

The heart of the thermal circuit breaker is the KLIXON® metal disc. At a predetermined overload, the heat caused by current passing through the disc causes the disc to reverse its curvature, or snap. This snapping action separates the electrical contacts and opens the circuit.

Trip curves provide the approximate time vs current characteristics based on the ambient "room" temperature of 77°F (25°C). Should your application require performance characteristics beyond the ambient "room" temperature of 77°F (25°C), derating curves provide additional data for ambient temperatures significantly higher or lower than standard room temperature.

KLIXON® thermal circuit breakers are available in automatic reset and manual reset. Some manual reset devices offer a switchable feature whereby the contacts can be manually opened to de-energize the circuit. For the automatic reset device, the circuit stays open until the disc cools and returns to its original curvature, completing the circuit. For the trip-free manual reset device, the contacts will remain open until the device's pushbutton is depressed to reset the device and complete the circuit.





# KLIXON<sup>®</sup>

"With over 97 years of experience in a myriad of industries and mission-critical applications, Sensata Technologies is one of the world's leading suppliers of sensing, electrical protection, control and power management solutions.

Motors, machines, equipment and vehicles in the industrial, heating, ventilation, air conditioning, appliance, automotive, recreational, mobile work, data and telecommunications industries operate safely and efficiently thanks to reliable and robust Sensata circuit protectors, switches, and sensors. Our products sense and monitor position, temperature and pressure, provide power protection and help manage challenging DC-to-AC power conversions.

From design to manufacturing and every business process in between, our people strive not just to meet standards of excellence but to set them. Serving you is mission-critical to us."

**Martha Sullivan**, *President and Chief Executive Officer, Sensata Technologies*



Cross Reference for KLIXON® Thermal Circuit Breakers

17.5 Amps	20 Amps	25 Amps	30 Amps	35 Amps	40 Amps	45 Amps	50 Amps	60 Amps	70 Amps	80 Amps	90 Amps	100 Amps	105 Amps	120 Amps	135 Amps	150 Amps	175 Amps	200 Amps	PAGE	SERIES	TYPE
•	•	•	•	•	•														6	CM	COMMERCIAL
•	•	•	•	•	•														6	CA	
•	•	•	•	•	•														6	CDM	
•	•	•	•	•	•														6	CDA	
•	•	•	•	•	•		•	•											8	7851	
•	•	•	•	•	•		•	•											8	7854	
				•	•	•	•	•	•	•	•	•	•	•	•	•			10	SDLS	
				•	•	•	•	•	•	•	•	•	•	•	•	•			12	SDLM	
				•	•	•	•	•	•	•	•	•	•	•	•	•			12	SDLA	
				•	•	•	•	•	•	•	•	•	•	•	•	•			12	SLA	
				•	•	•	•	•	•	•	•	•	•	•	•	•			14	FDLM	
				•	•	•	•	•	•	•	•	•	•	•	•	•			14	FDLA	
				•	•	•	•	•	•	•	•	•	•	•	•	•			14	FDLS	
				•	•	•	•	•	•	•	•	•	•	•	•	•			14	FDLT	
				•	•	•	•	•	•	•	•	•	•	•	•	•			16	6766-19	
																	•	•	18	7855-6	PRECISION
																	•	•	18	7855-7	
•	•	•	•	•	•														20	PDM	
•	•	•	•	•	•														20	PDA	
				•	•	•	•	•	•	•	•		•	•	•	•			22	PDLM	
				•	•	•	•	•	•	•	•		•	•	•	•			22	PDLA	
	•	•	•	•															24	PSM	
	•	•	•	•															24	PSA	
	•	•	•																28	9115-5	
	•	•	•																28	9115-6	



# KLIXON® | C Series (CA, CM, CDA, CDM)

## 2 to 40 Amp Commercial Thermal Circuit Breaker

### FEATURES

- 30VDC or 120VAC, 2 to 40 Amps
- Open and closed construction
- Automatic and manual reset options
- Ignition protected SAE J1171
- Weatherproof SAE J553
- UL Recognized E36869

### DESCRIPTION

The KLIXON® C series thermal breakers are designed to protect wiring and meet the harshest environmental requirements. The C series closed construction circuit breakers are weatherproof sealed for protection against moisture, dust, grease, fuel vapors and other harsh environments. The C series breakers are compact, lightweight and designed to interrupt short circuits or overloads, and combine trip-free protection with fast response time. Typical applications are protection of wire cable of accessory circuits, equipment and battery protection in construction and off-road equipment, marine, recreational vehicles (RV's), mining, agricultural equipment and electric (hybrid) vehicles.

### ORDERING INFORMATION

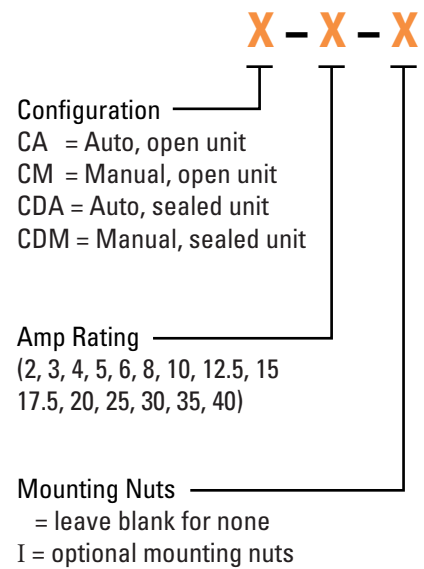

### PERFORMANCE CHARACTERISTICS

Calibration : 200% rated current, 77°F (25°C)	2 to 10 amps : 20 to 150 seconds 12.5 to 40 amps : 5 to 55 seconds
Ultimate Trip at 77°F (25°C)	Must hold 100%, Must trip 135%
Endurance	Per SAE J553
Interrupt Current Capacity	Per SAE J553 and ABYC E-11
Vibration	10G MIL-STD-202 Method 204, Condition A
Salt Spray	MIL-STD-202 Method 101D (sealed only)
Dielectric Strength	MIL-STD-202 Method 301, 1500VAC min
Insulation Resistance	MIL-STD-202 Method 302, Condition B, 100 MΩ min
Weight (with mounting nuts)	CDM: 48 grams max    CDA: 41 grams max CM : 37 grams max    CA : 32 grams max

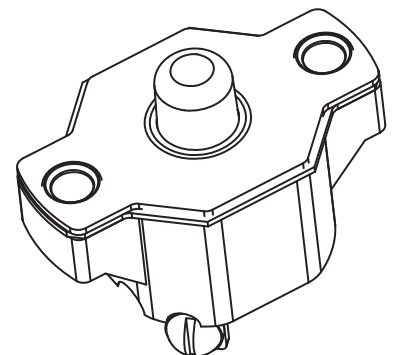

## TRIP CURVE - Approximate Time, Current Characteristics At 77°F (25°C)

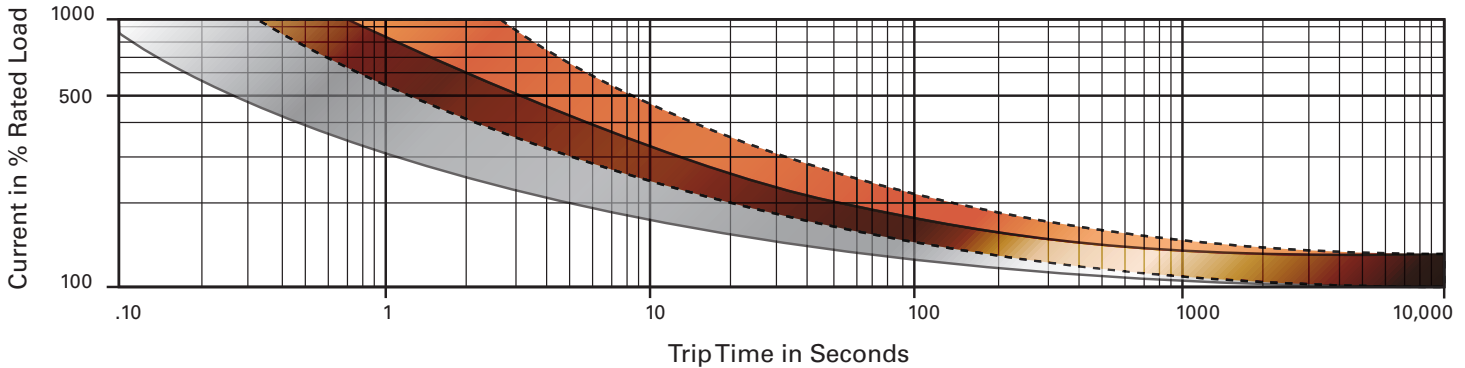

Dotted Lines: 10 amps or below  
 Solid Lines: Above 10 amps

## DIMENSIONS

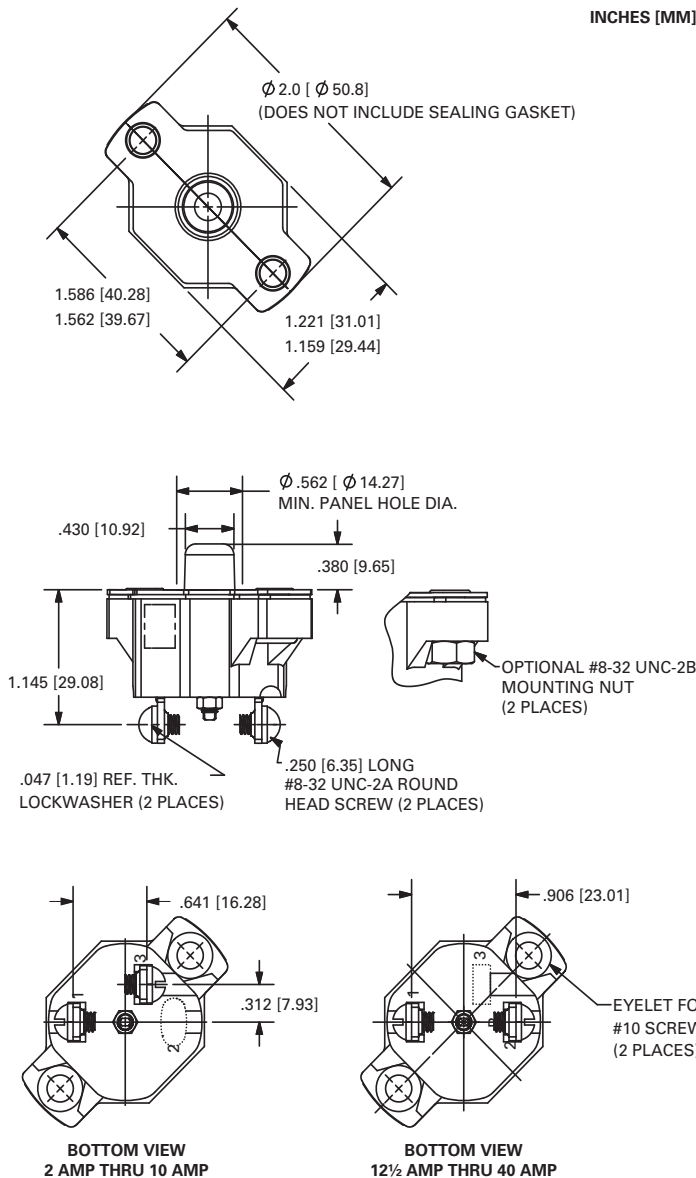

## DERATING CURVE

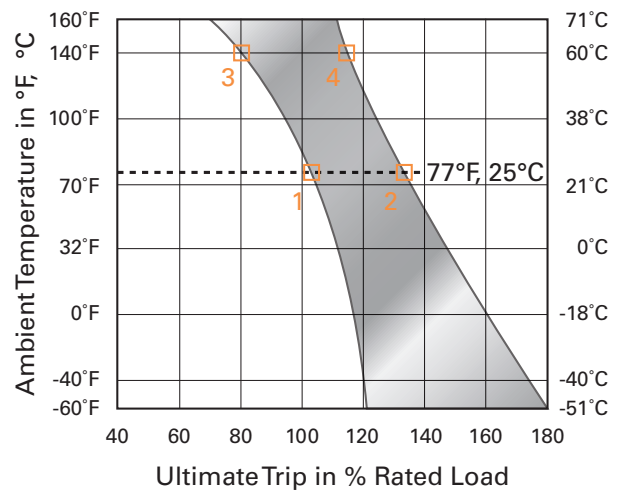

Performance characteristics are based on room temperature (77°F, 25°C). Consult derating curve for ambient temperatures significantly higher or lower than standard room temperature.

*Example:* At 77°F (25°C) the device is calibrated to hold at 100% of rated current (1) and trip at 135% of rated current (2). At 140°F (60°C), the same device will hold at approximately 78% of rated current (3), and trip at approximately 115% of rated current (4).

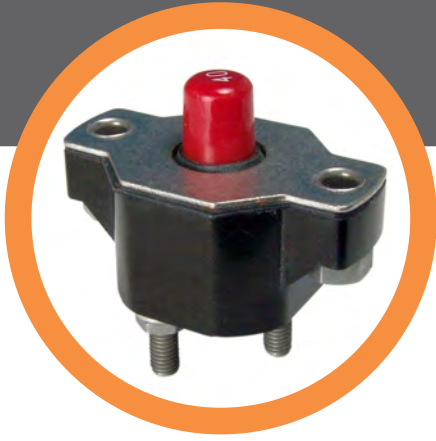

# KLIXON® | 7851 & 7854 Series

## 12.5 to 60 Amp Commercial Thermal Circuit Breaker

### FEATURES

- 30VDC or 120VAC, 12.5 to 60 Amps
- Sealed assemblies, manual and automatic reset options
- Ignition protected SAE J1171
- Weatherproof SAE J553
- UL Recognized E36869

### DESCRIPTION

The KLIXON® 7851 and 7854 series thermal breakers were designed to protect wiring and meet the harshest environmental requirements. The 7851 and 7854 series closed construction circuit breakers are weatherproof sealed for protection against moisture, dust, grease, fuel vapors and other harsh environments. The 7851 and 7854 series breakers are compact, lightweight and designed to interrupt short circuits or overloads, and combine trip-free protection with fast response time. Typical applications are protection of wire cable of accessory circuits, equipment and battery protection in construction and off-road equipment, marine, recreational vehicles (RV's), mining, agricultural equipment and electric (hybrid) vehicles.

### ORDERING INFORMATION

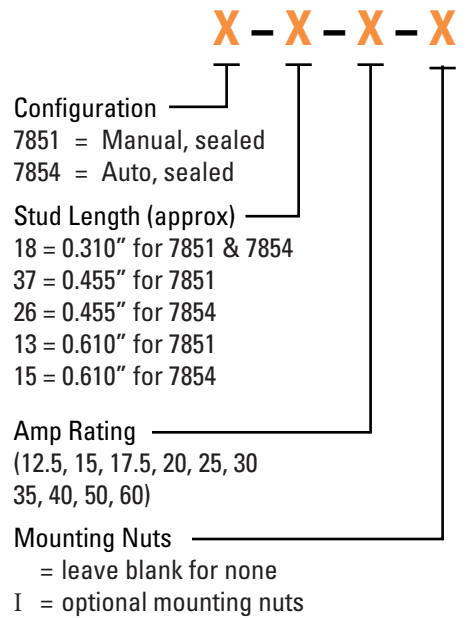

### PERFORMANCE CHARACTERISTICS

Calibration : 200% rated current, 77°F (25°C)	12.5 to 60 amps : 5 to 55 seconds
Ultimate Trip At 77°F (25°C)	Must hold 100%, Must trip 135%
Endurance	Per SAE J553
Interrupt Current Capacity	Per SAE J553 and ABYC E-11
Vibration	10G MIL-STD-202 Method 204, Condition A
Salt Spray	MIL-STD-202 Method 101D
Dielectric Strength	MIL-STD-202 Method 301, 1500VAC min
Insulation Resistance	MIL-STD-202 Method 302, Condition B, 100MΩ min
Weight (with mounting nuts)	7851 : 54 grams max 7854 : 49 grams max

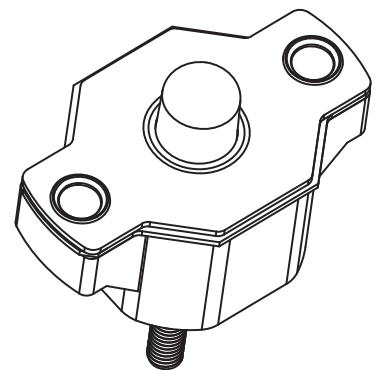



## TRIP CURVE - Approximate Time, Current Characteristics At 77°F (25°C)

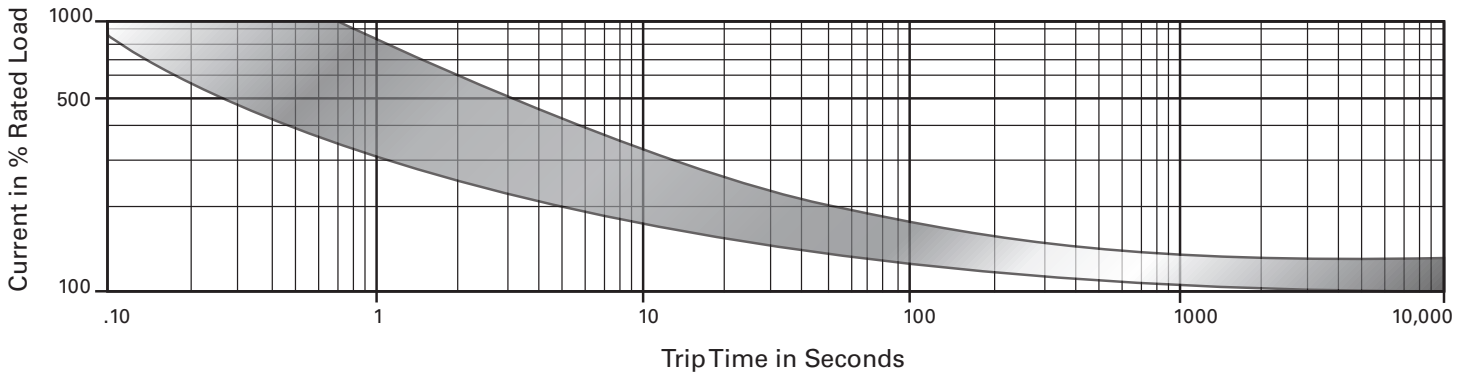

## DIMENSIONS

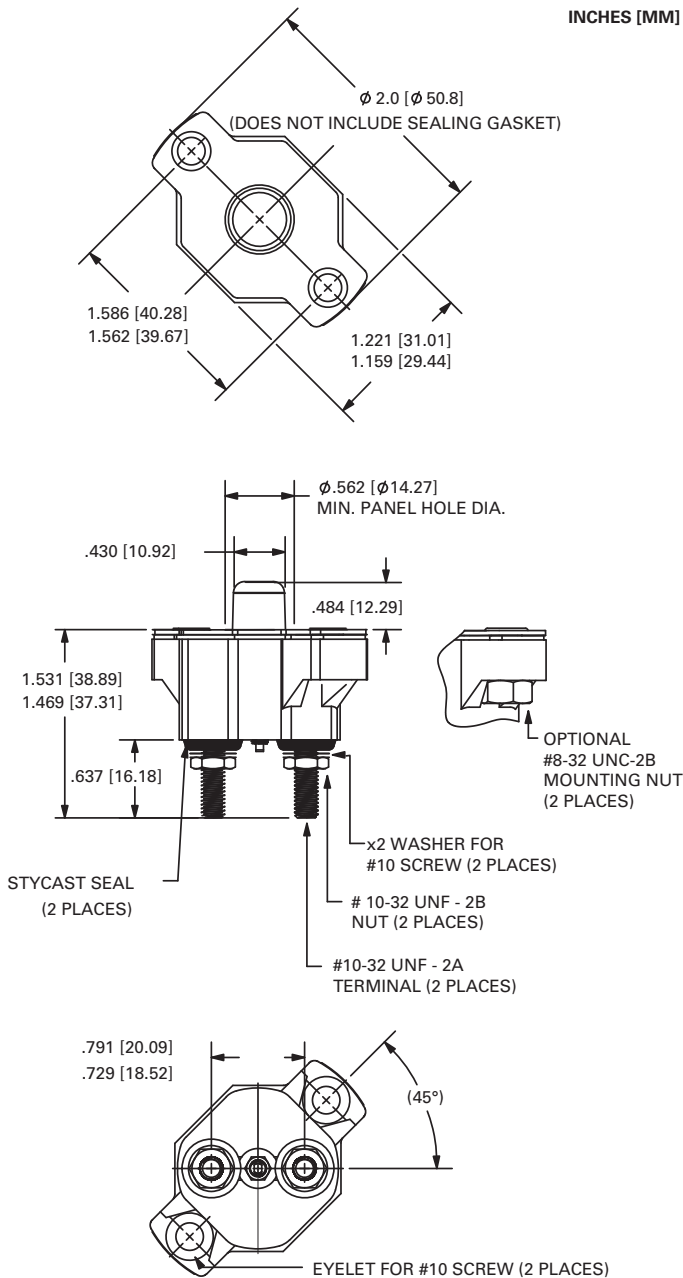

## DERATING CURVE

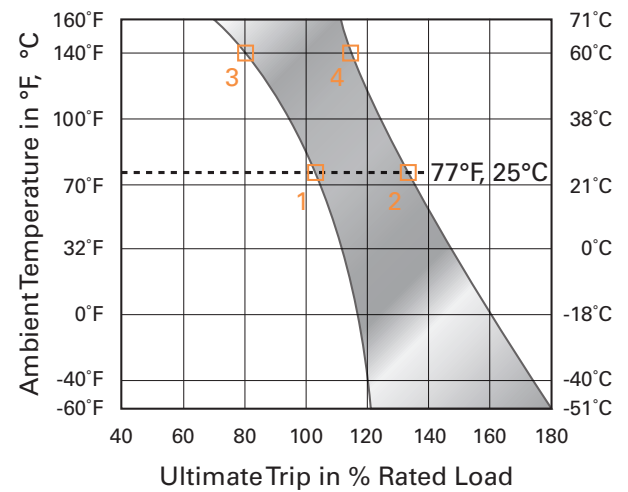

Performance characteristics are based on room temperature (77°F, 25°C). Consult Derating curve for ambient temperatures significantly higher or lower than standard room temperature.

*Example:* At 77°F (25°C) the device is calibrated to hold at 100% of rated current (1) and trip at 135% of rated current (2). At 140°F (60°C), the same device will hold at approximately 78% of rated current (3), and trip at approximately 115% of rated current (4).



# KLIXON® | SDLS Series (SDLS, SDLT)

## 35 to 150 Amp Thermal Circuit Breaker

### FEATURES

- 30VDC, 35 to 150 Amps
- Weatherproof, ignition protected, trip-free design
- Ability to accommodate heavy gauge wire lugs across terminal studs
- SAE J1625 surface vehicles circuit breaker standards
- SAE J1171 marine circuit breaker standards
- Meets 5000 amps @ 12VDC for interrupt capacity per ABYC E-11, DC electrical systems of boats

### DESCRIPTION

The KLIXON® SDLS series thermal breaker series are designed for up to 150 amps, manual reset with trip indication in a single device. The internal components are enclosed in a vibration resistant, weatherproof, ignition protected, robust casing to provide protection in the harshest environments found in heavy truck, off-road, marine and construction applications. The SDLS series thermal breakers are designed to combine trip-free protection with fast response time.

### ORDERING INFORMATION

**SDL X - X - X**

Configuration

- S = Manual Reset / Switch
- T = Trip Lever

Amp Rating

(35, 40, 45, 50, 60, 70, 80, 90, 100, 105, 110, 120, 135, 150)

Terminals\*

1 = 1/4-28 UNF-2A

\* Other non-standard option available, consult factory

### PERFORMANCE CHARACTERISTICS

Calibration : 200% rated current, 77°F (25°C)	35 to 150 Amps : 8 to 100 seconds
Ultimate Trip At 77°F (25°C)	Must hold 100%, Must trip 135%
Endurance	Per SAE J1625
Interrupt Current Capacity	Per SAE J1625 and ABYC E-11
Mechanical Vibration	Per SAE J1455, 4G's 10-2K Hz
Voltage Breakdown	1500VAC Minimum per MIL-STS-202, Method 301
Salt Spray	Per SAE J1455, 96 hours
Weight	75 grams max

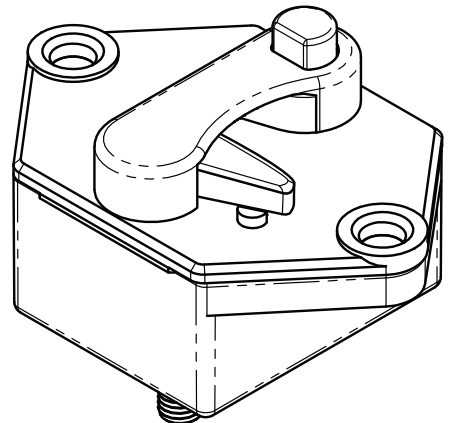

## TRIP CURVE - Approximate Time, Current Characteristics At 77°F (25°C)

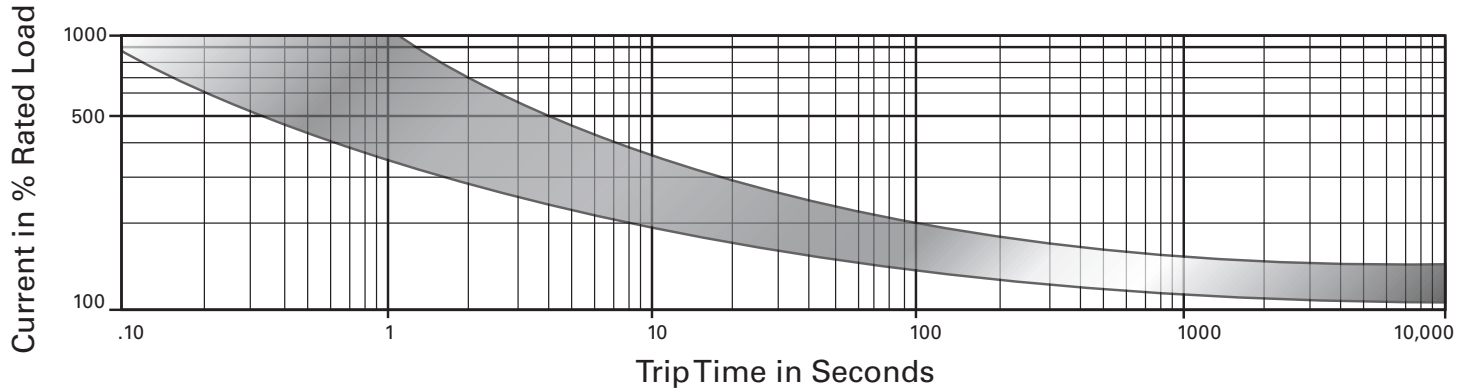

## DIMENSIONS - SDLS

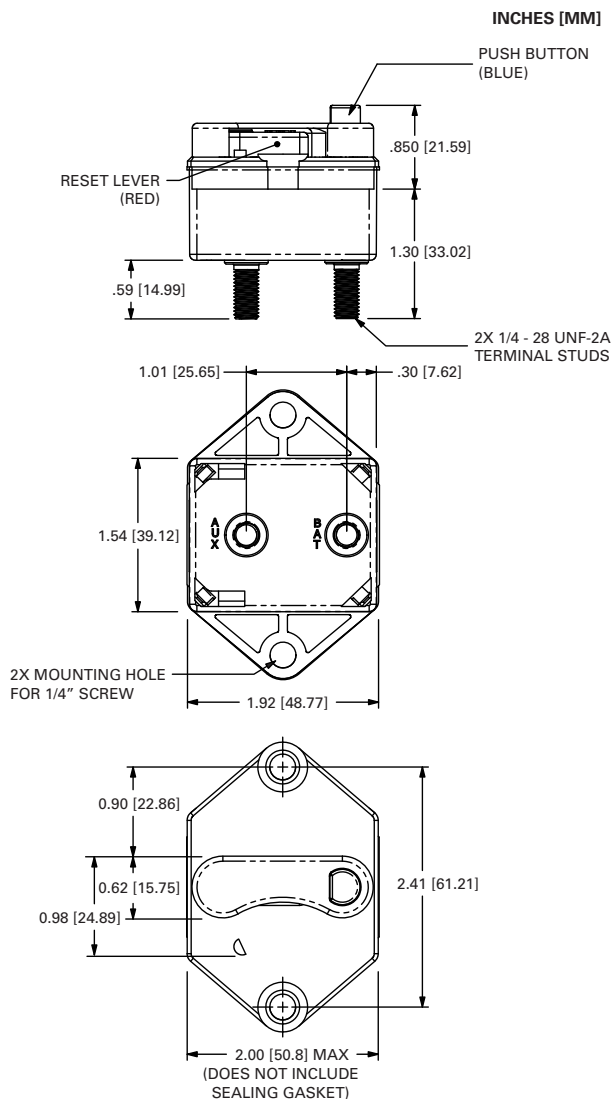

## DERATING CURVE

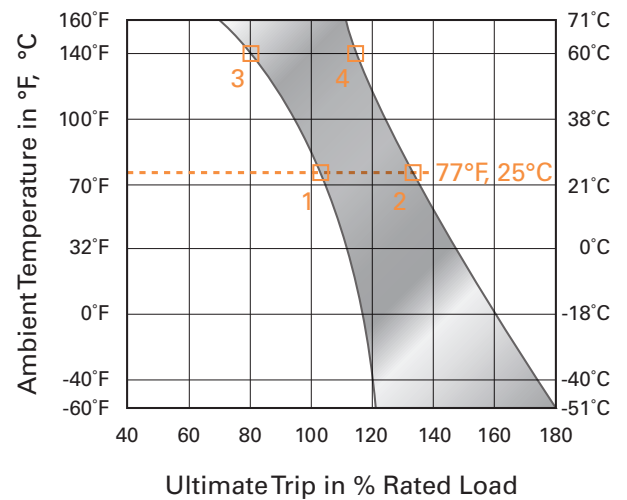

Performance characteristics are based on room temperature (77°F, 25°C). Consult Derating curve for ambient temperatures significantly higher or lower than standard room temperature.

*Example:* At 77°F (25°C) the device is calibrated to hold at 100% of rated current (1) and trip at 135% of rated current (2). At 140°F (60°C), the same device will hold at approximately 78% of rated current (3), and trip at approximately 115% of rated current (4).

### Notes:

1. Dimension does not include sealing gasket.



# KLIXON® | F Series (FDLA, FDLM, FDLS, FDLT)

## 35 to 150 Amp Surface Mount Thermal Circuit Breaker

### FEATURES

- 30VDC, 35 to 150 Amps
- Weatherproof, ignition protected, trip-free design
- Stronger housing material for increased robustness
- Ability to accommodate heavy gauge wire lugs across terminal studs
- SAE J1625 surface vehicles circuit breaker standards
- SAE J1171 marine circuit breaker standards
- Meets 5000 amps @ 12VDC for interrupt capacity per ABYC E-11, DC electrical systems of boats

### DESCRIPTION

The KLIXON® F series thermal breaker series are designed for surface mount applications and are available with automatic trip, manual reset, trip indication, and a switchable option in a single device. The internal components are enclosed in a vibration resistant, weatherproof, robust casing to provide protection in the harshest environments found in heavy truck, off-road, marine and construction applications. The F series thermal breakers are designed to combine trip-free protection with fast response time. Terminal studs are available in 1/4" or a larger 3/8" option to allow higher torque connections and provide wider spacing for heavy gauge wire lugs.

### ORDERING INFORMATION

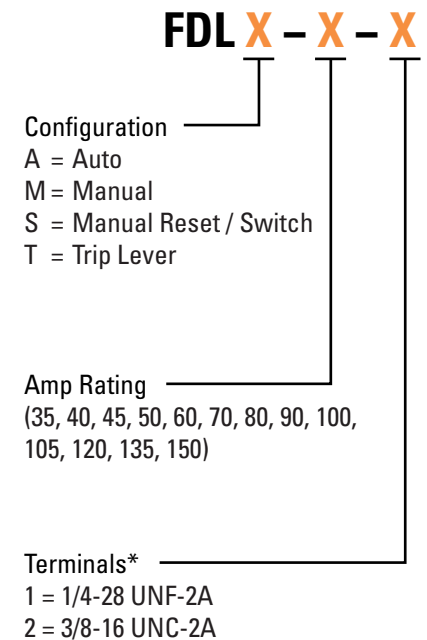

\* Other non-standard option available, consult factory

### PERFORMANCE CHARACTERISTICS

Calibration : 200% rated current, 77°F (25°C)	35 to 150 Amps : 8 to 100 seconds
Ultimate Trip At 77°F (25°C)	Must hold 100%, Must trip 135%
Endurance	Per SAE J1625
Interrupt Current Capacity	Per SAE J1625 and ABYC E-11
Mechanical Vibration	Per SAE J1455, 4G's 10-2K Hz
Voltage Breakdown	Per SAE J1625 500VAC
Salt Spray	Per SAE J1455, 96 hours
Weight (with 3/8" terminal studs)	153 grams max

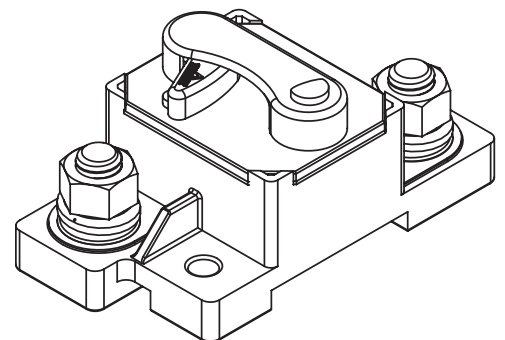

## TRIP CURVE - Approximate Time, Current Characteristics At 77°F (25°C)

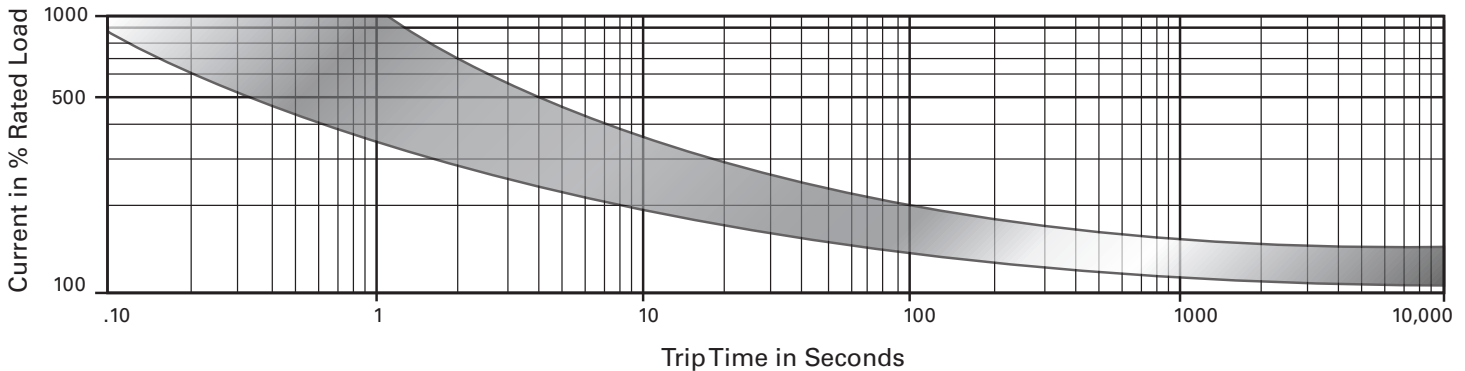

## DIMENSIONS - FDLS

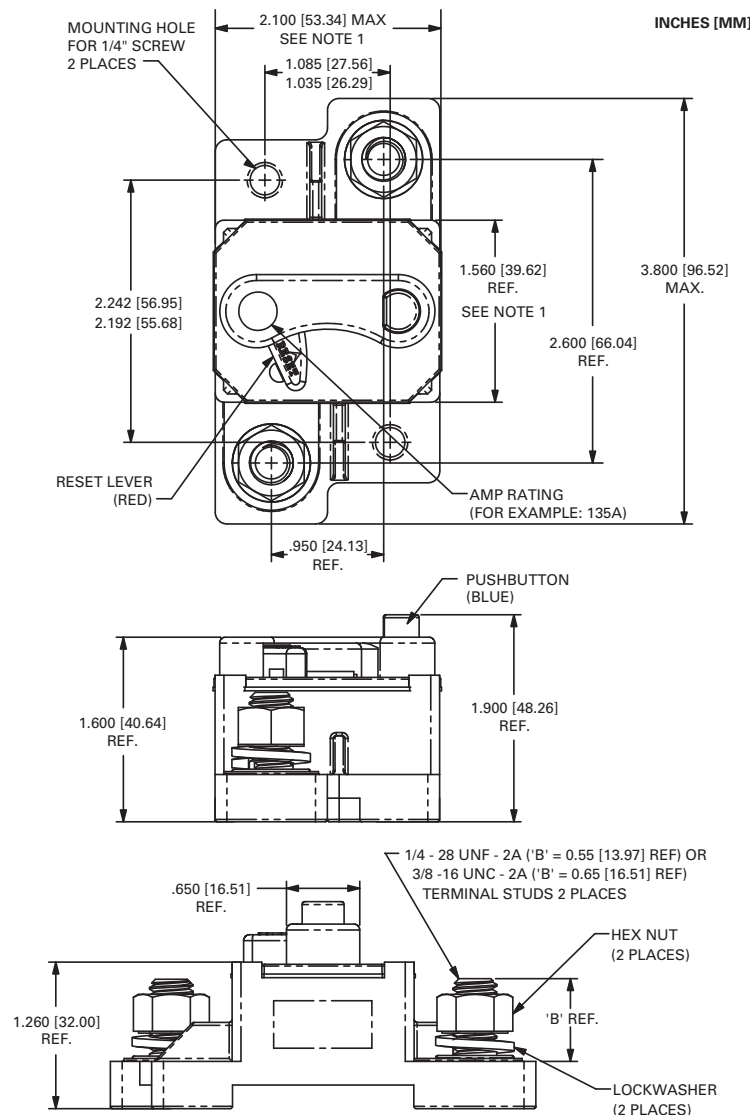

## DERATING CURVE

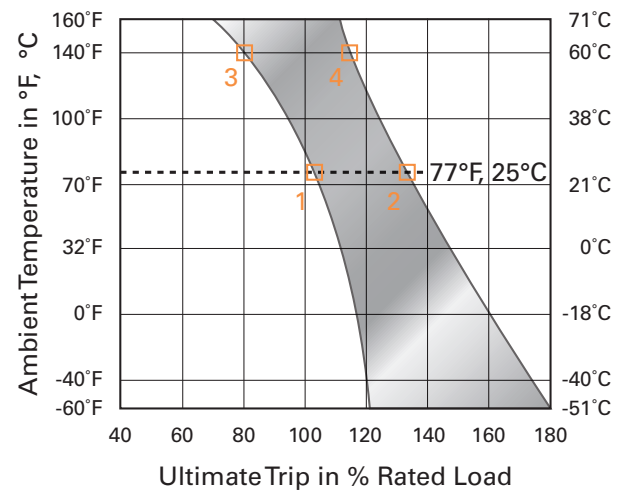

Performance characteristics are based on room temperature (77°F, 25°C). Consult Derating curve for ambient temperatures significantly higher or lower than standard room temperature.

*Example:* At 77°F (25°C) the device is calibrated to hold at 100% of rated current (1) and trip at 135% of rated current (2). At 140°F (60°C), the same device will hold at approximately 78% of rated current (3), and trip at approximately 115% of rated current (4).

### Notes:

1. Dimension does not include sealing gasket.



# KLIXON® | S Series (SLA, SDLA, SDLM)

## 35 to 150 Amp Commercial Thermal Circuit Breaker

### FEATURES

- 30VDC, 35 to 150 Amps
- Open and sealed assemblies, manual and automatic reset options
- Ignition protected
- UL Recognized E69772

### DESCRIPTION

The KLIXON® S series thermal breakers are designed to protect wiring and meet the harshest environmental requirements. The sealed circuit breakers are weatherproof for protection against moisture, dust, grease, fuel vapors and other harsh environments. The S series breakers are lightweight and designed to interrupt short circuits or overloads and combine trip-free protection with fast response time. Typical applications are protection of wire and cable of accessory circuits, equipment and battery protection on heavy trucks, buses, construction equipment, off-road vehicles, marine, recreational vehicles (RVs) and electric (hybrid) vehicles, and battery chargers.

The S series is available in both open and sealed body configurations with manual and automatic reset options.

### ORDERING INFORMATION

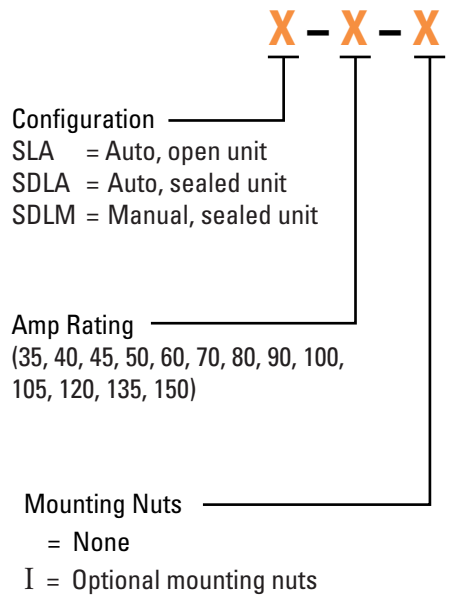

### PERFORMANCE CHARACTERISTICS

Calibration : 200% rated current, 77°F (25°C)	35 to 150 Amps : 8 to 100 seconds
Ultimate Trip At 77°F (25°C)	Must hold 100%, Must trip 135%
Endurance	Per SAE J1625
Interrupt Current Capacity	Per SAE J1625 and ABYC E-11
Mechanical Vibration	Per SAE J1455, 4G's, 10-2K Hz
Voltage Breakdown	Per SAE J1625 500VAC
Salt Spray	Per SAE J1625, 96 hours
Voltage Drop	Per SAE J1625
Weight (with mounting nuts)	SDLM (A) : 75 grams (71 grams) max SLA : 62 grams max

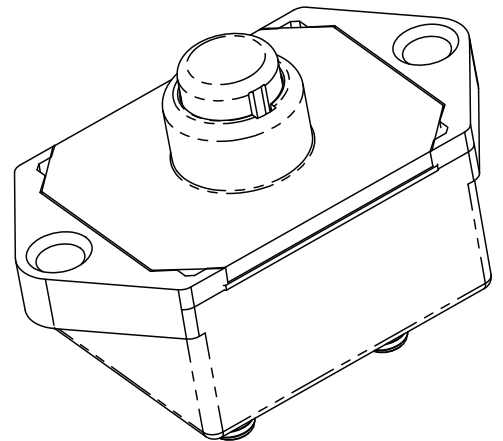

### TRIP CURVE - Approximate Time, Current Characteristics At 77°F (25°C)

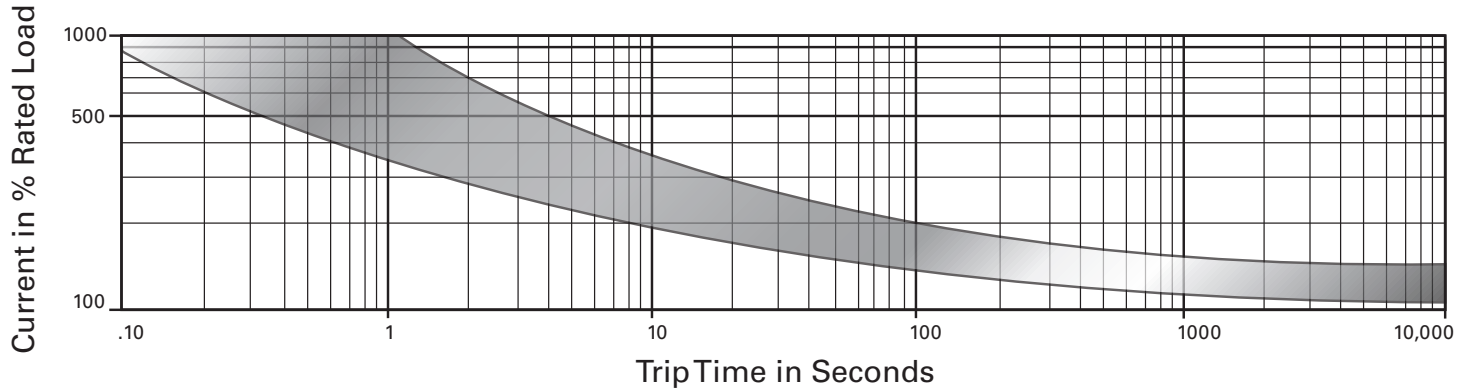

### DIMENSIONS - SDLM

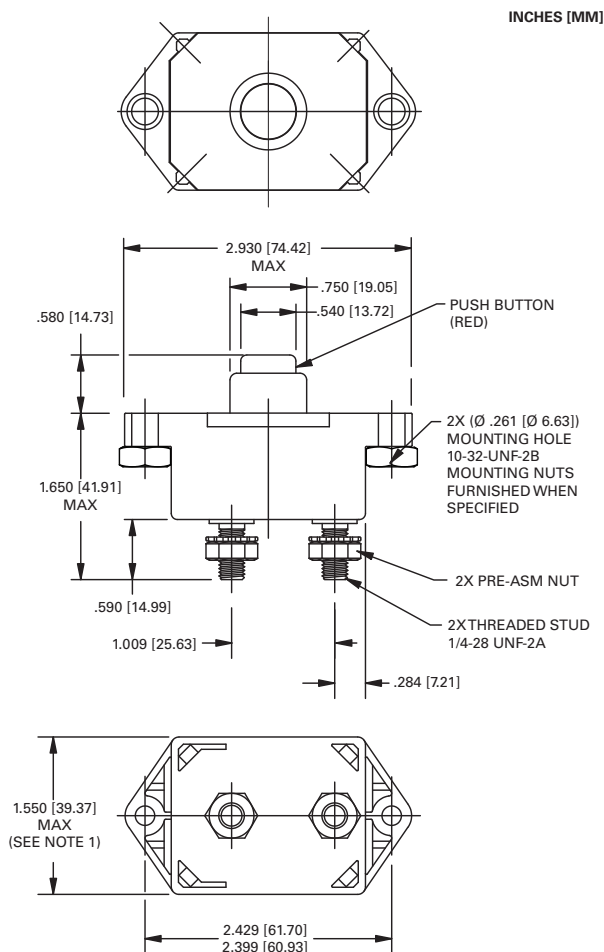

### DERATING CURVE

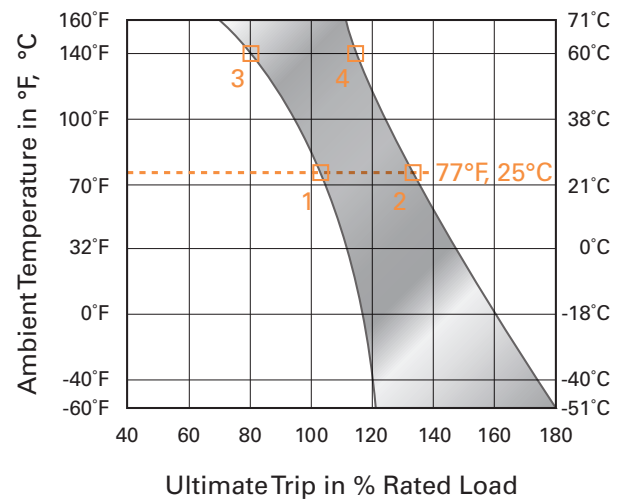

Performance characteristics are based on room temperature (77°F, 25°C). Consult Derating curve for ambient temperatures significantly higher or lower than standard room temperature.

*Example:* At 77°F (25°C) the device is calibrated to hold at 100% of rated current (1) and trip at 135% of rated current (2). At 140°F (60°C), the same device will hold at approximately 78% of rated current (3), and trip at approximately 115% of rated current (4).

#### Notes:

1. Dimension does not include sealing gasket.

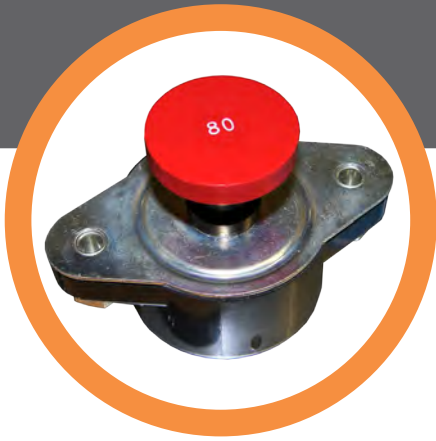

## KLIXON® | 6766-19 Series

### 35 to 150 Amp Commercial Thermal Circuit Breaker

#### FEATURES

- 30VDC, 35 to 150 Amps
- Manual reset
- Weatherproof SAE J1625 and ideally suited for rugged applications
- Ignition protected SAE J1171

#### DESCRIPTION

The KLIXON® 6766-19 series is a manually switchable thermal circuit breaker that is designed to meet the harshest environmental requirements. The 6766-19 series breakers are weatherproof for protection against moisture, dust, grease, fuel vapors, and other harsh environments. The 6766-19 series of breakers is suited for rugged applications, where a robust switchable breaker is required for accessory, equipment and battery protection on heavy trucks, buses, construction equipment, off-road vehicles, marine, recreational vehicles (RVs) and electric (hybrid) vehicles.

#### ORDERING INFORMATION

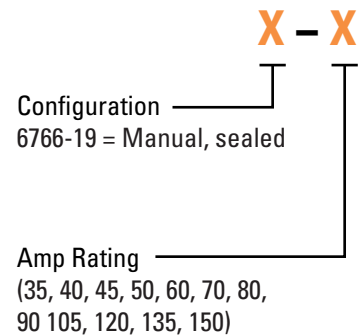

#### PERFORMANCE CHARACTERISTICS

Calibration : 200% rated current, 77°F (25°C)	35 to 150 Amps : 8 to 100 seconds
Ultimate Trip At 77°F (25°C)	Must hold 100%, Must trip 135%
Endurance	Per SAE J1625
Interrupt Current Capacity	Per SAE J1625 and ABYC E-11
Vibration	Per SAE J1455, 4G's, 10-2K Hz
Dielectric Strength	MIL-STD-202 Method 301, 1500VAC min
Insulation Resistance	MIL-STD-202 Method 302, Condition B, 100 MΩ min
Weight (with mounting nuts)	6766-19 : 129 grams max

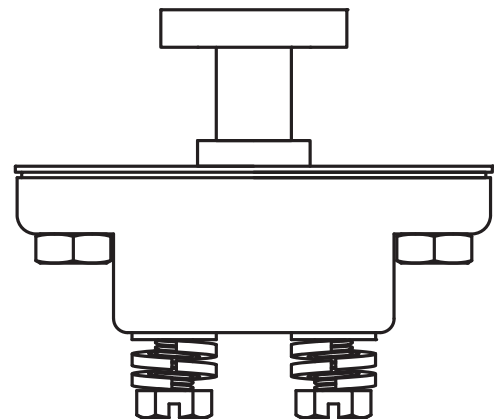



## TRIP CURVE - Approximate Time, Current Characteristics At 77°F (25°C)

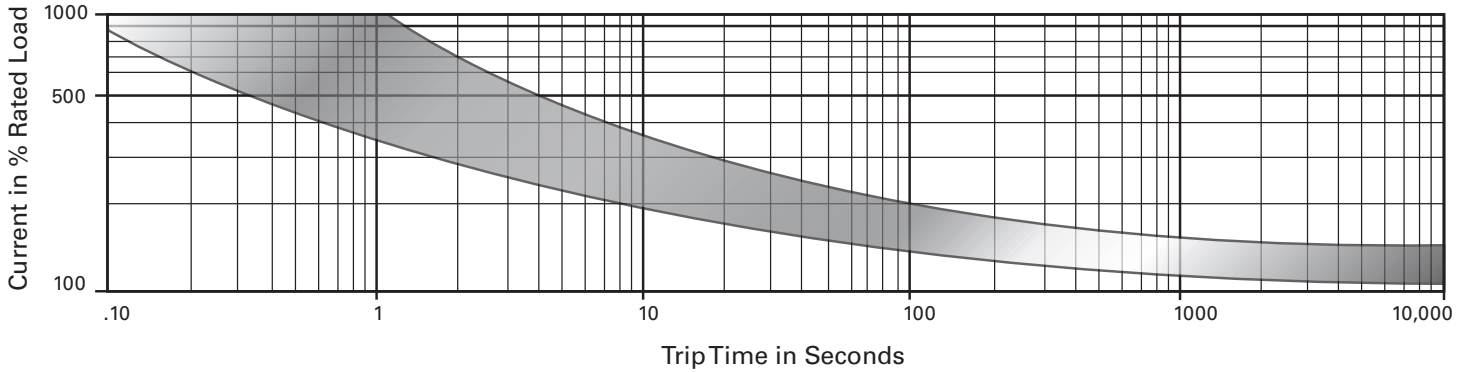

## DIMENSIONS - 6766-19

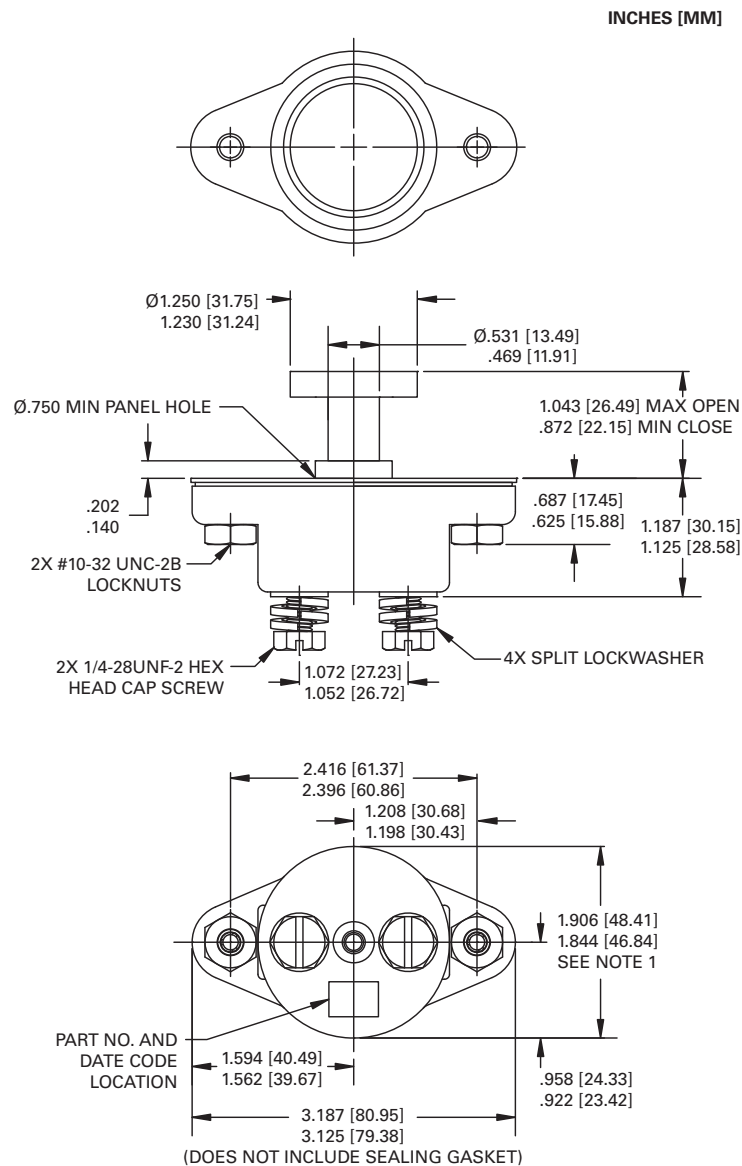

## DERATING CURVE

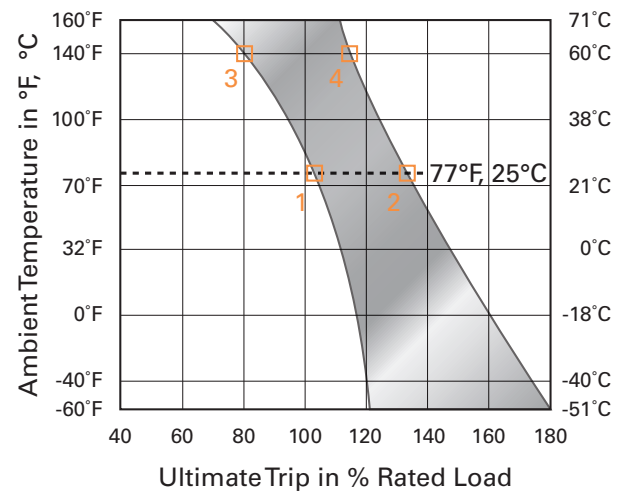

Performance characteristics are based on room temperature (77°F, 25°C). Consult Derating curve for ambient temperatures significantly higher or lower than standard room temperature.

*Example:* At 77°F (25°C) the device is calibrated to hold at 100% of rated current (1) and trip at 135% of rated current (2). At 140°F (60°C), the same device will hold at approximately 78% of rated current (3), and trip at approximately 115% of rated current (4).



## KLIXON® | 7855 Series

### 175 to 200 Amp Commercial Thermal Circuit Breaker

#### FEATURES

- 30VDC, 175 to 200 Amps
- Sealed assemblies, manual and automatic reset options
- Ignition protected
- 7855-6 meets CID A-A-55571/03 specifications
- 7855-7 meets CID A-A-55571/08 specifications

#### DESCRIPTION

The KLIXON® 7855 series thermal breaker are designed to meet the harshest environmental requirements. The 7855 series breakers are weatherproof for protection against moisture, dust, grease, fuel vapors and other harsh environments. The 7855 series breakers are designed to interrupt short circuits or overloads and combine trip free protection with fast response time. The 7855 series of breakers typical applications are protection of wire and cable of accessory circuits, military vehicles, lift gates, and recreational vehicles.

#### ORDERING INFORMATION

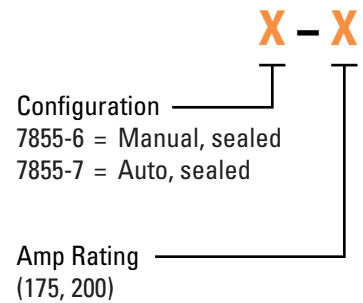

#### PERFORMANCE CHARACTERISTICS

Calibration : 200% rated current, 77°F (25°C)	8 to 100 seconds
Ultimate Trip At 77°F (25°C)	Must hold 100%, Must trip 138%
Endurance	Manual 500 cycles @ 200% Automatic 2000 cycles @ 200%
Interrupt Current Capacity	Per SAE J1625, 900A
Vibration	10G MIL-STD-202 Method 204, Condition A
Dielectric Strength	MIL-STD-202, Method 301, 1500VAC min
Insulation Resistance	MIL-STD-202, Method 302, Condition B, 100 MΩ min
Weight	7855-6 : 241 grams max 7855-7 : 237 grams max

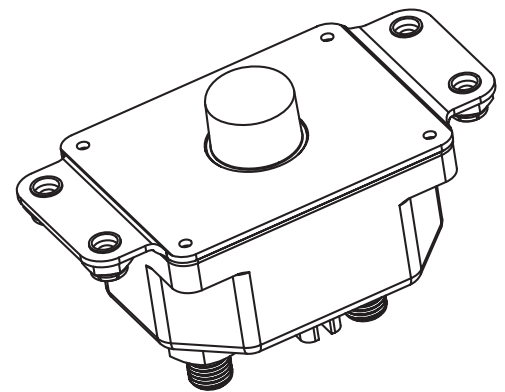

## TRIP CURVE - Approximate Time, Current Characteristics At 77°F (25°C)

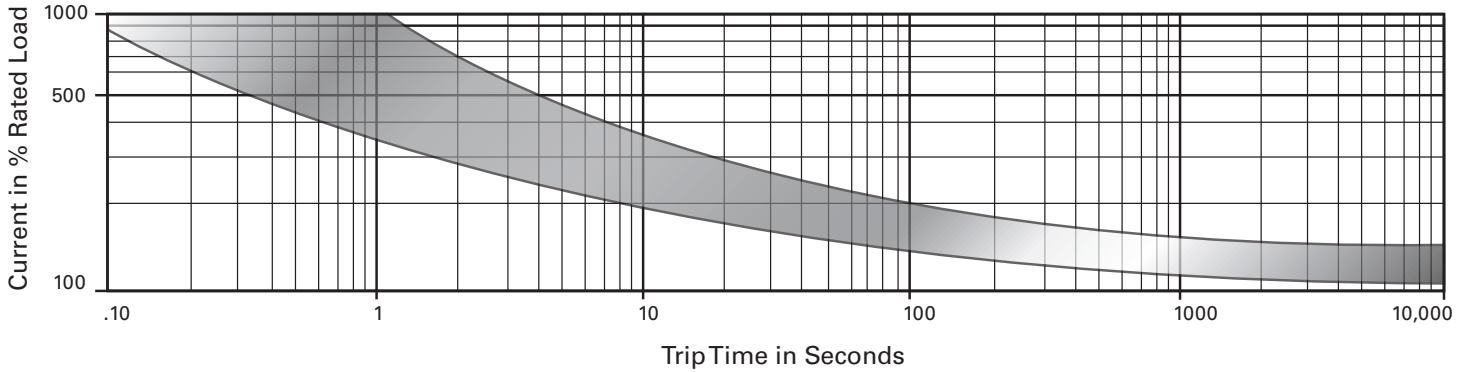

## DIMENSIONS - 7855-6

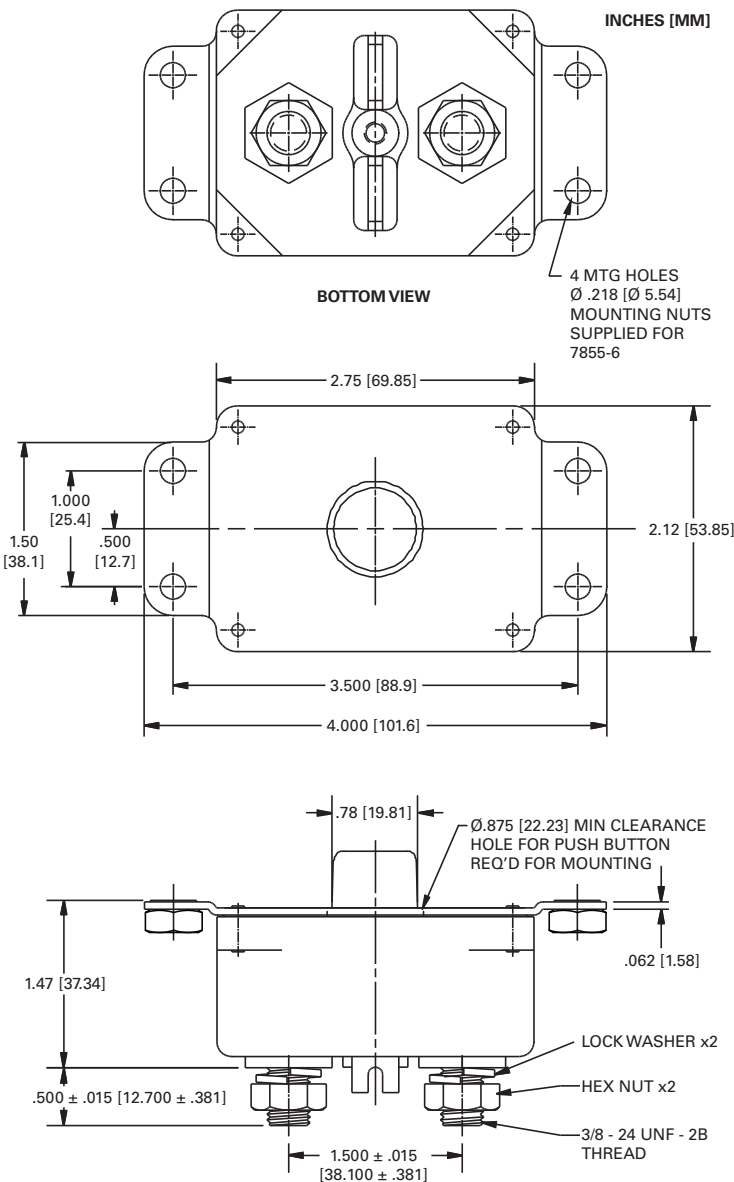

## DERATING CURVE

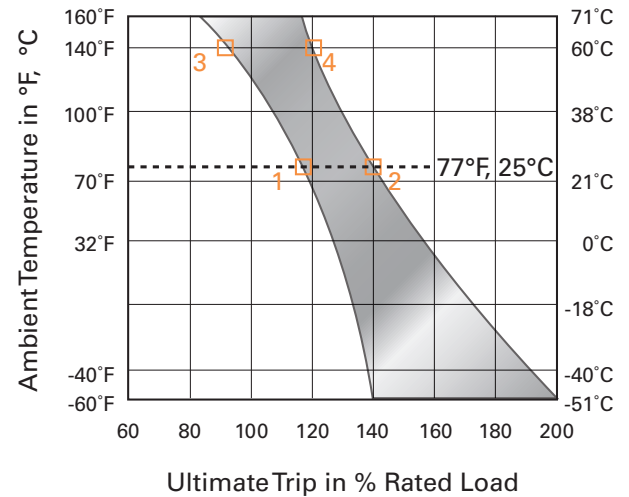

Performance characteristics are based on room temperature (77°F, 25°C). Consult Derating curve for ambient temperatures significantly higher or lower than standard room temperature.

*Example:* At 77°F (25°C) the device is calibrated to hold at 110% of rated current (1) and trip at 138% of rated current (2). At 140°F (60°C), the same device will hold at approximately 92% of rated current (3), and trip at approximately 120% of rated current (4).



# KLIXON® | Small Frame PD Series (PDA, PDM)

## 2 to 40 Amp Precision Thermal Circuit Breaker

### FEATURES

- 30VDC or 120VAC, 2 to 40 Amps
- Sealed assemblies, available in manual and automatic reset options
- Ignition protected
- UL Recognized E36869

### DESCRIPTION

The KLIXON® PD series thermal breakers are designed to protect wiring and meet the harshest environmental requirements. The PD series are weatherproof sealed for protection against moisture, dust, grease, fuel vapors and other harsh environments. The PD series breakers are compact, lightweight and designed to interrupt short circuits or overloads, and combine trip-free protection with fast response time. Typical applications are protection of wire and cable of accessory circuits, equipment and battery protection in construction and off-road equipment, marine, recreational vehicles (RV's), mining, agricultural equipment and electric (hybrid) vehicles.

The PD series is used in commercial and military applications.

### ORDERING INFORMATION

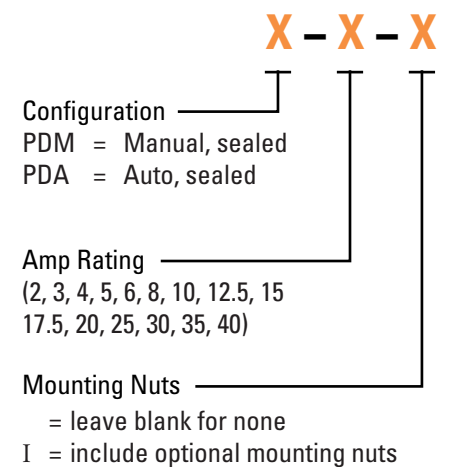

### PERFORMANCE CHARACTERISTICS

Calibration : 200% rated current, 77°F (25°C)	2 to 10 amps : 20 to 150 seconds 12.5 to 40 amps : 8 to 50 seconds
Ultimate Trip at 77°F (25°C)	Must hold 110%, must trip 138%
Endurance	Per SAE J553
Interrupt Current Capacity	Per SAE J553 and ABYC E-11
Vibration	10G MIL-STD-202 Method 204, Condition A
Mechanical Shock	MIL-STD-202 Method 213, Condition C, 100G
Salt Spray	MIL-STD-202 Method 101D
Dielectric Strength	MIL-STD-202 Method 301, 1500VAC min
Insulation Resistance	MIL-STD-202 Method 302, Condition B, 100 MΩ min
Weight (with mounting nuts)	PDM : 48 grams max PDA : 41 grams max

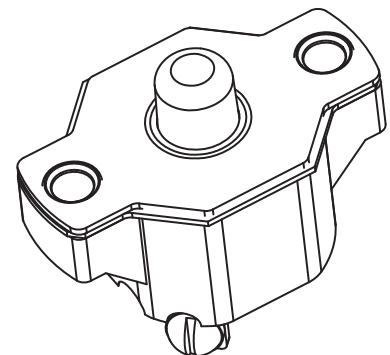

## TRIP CURVE - Approximate Time, Current Characteristics At 77°F (25°C)

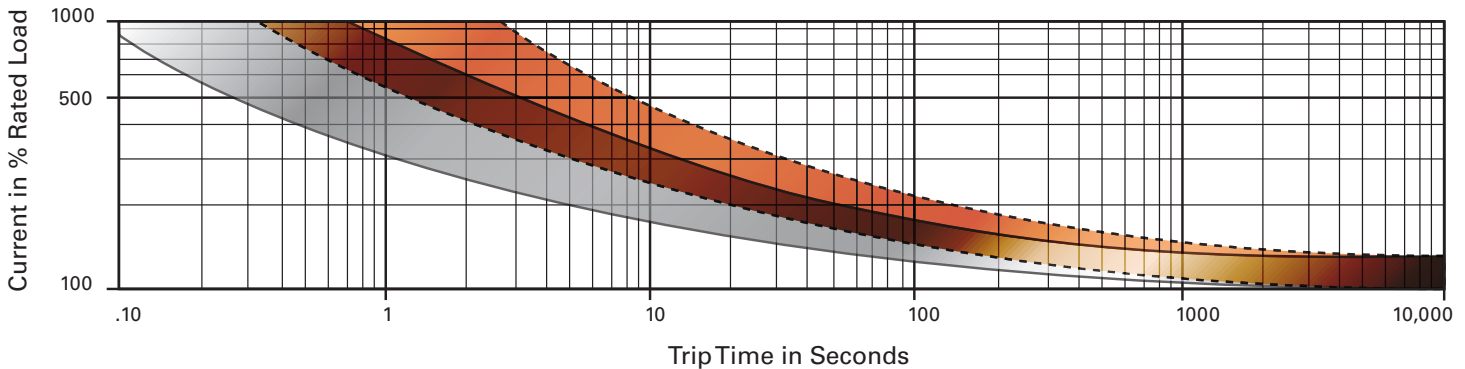

Dotted Lines: 10 amps or below  
 Solid Lines: Above 10 amps

## DIMENSIONS - PDM

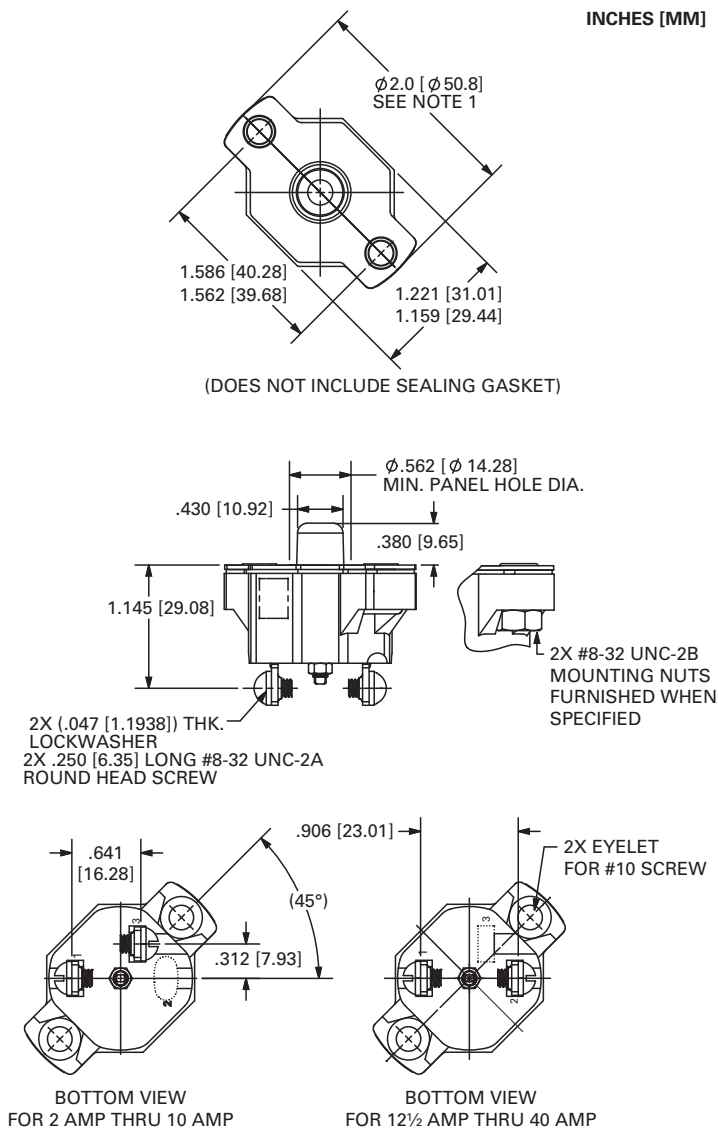

## DERATING CURVE

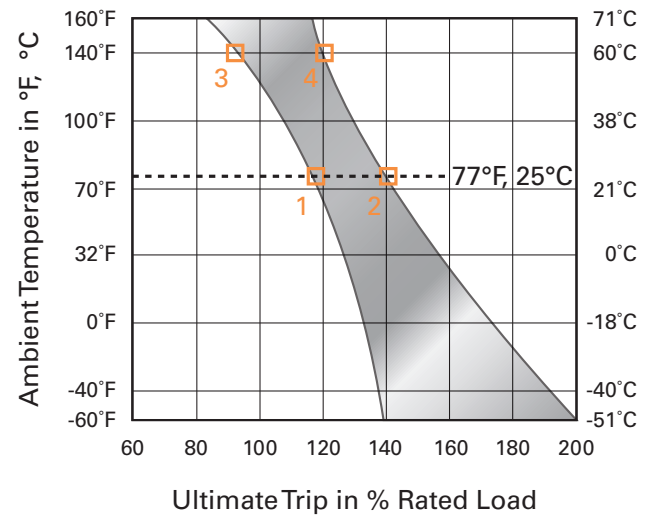

Performance characteristics are based on room temperature (77°F, 25°C). Consult Derating curve for ambient temperatures significantly higher or lower than standard room temperature.

Example: At 77°F (25°C) the device is calibrated to hold at 110% of rated current (1) and trip at 138% of rated current (2). At 140°F (60°C), the same device will hold at approximately 92% of rated current (3), and trip at approximately 120% of rated current (4).



# KLIXON® | Large Frame PD Series (PDLA, PDLM)

## 35 to 150 Amp Precision Thermal Circuit Breaker

### FEATURES

- 30VDC, 35 to 150 Amps
- Sealed assemblies, available in manual and automatic reset options
- Ignition protected & CCC certified
- PDLM meets CID A-A-55571/04 specifications
- PDLA meets CID A-A-55571/07 specifications

### DESCRIPTION

The KLIXON® PDL series thermal breakers are designed to meet the harshest environmental requirements. The PDL series breakers are weatherproof for protection against moisture, dust, grease, fuel vapors, and other harsh environments. The PDL series of breakers are designed to interrupt short circuits or overloads and combine trip-free protection with fast response time. The PDL series of breakers can be used in commercial and military vehicles and equipment where more precise ultimate trip characteristics are required.

### ORDERING INFORMATION

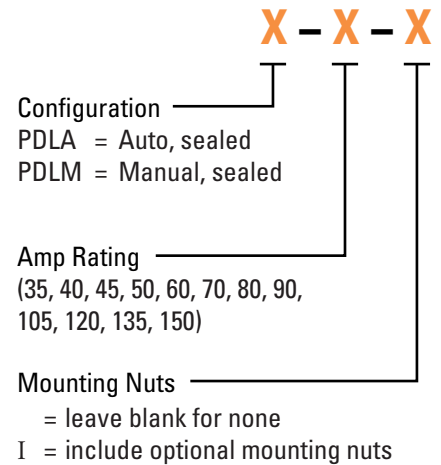

### PERFORMANCE CHARACTERISTICS

Calibration : 200% rated current, 77°F (25°C)	8 to 100 seconds
Ultimate Trip At 77°F (25°C)	Must hold 100%, Must trip 138%
Endurance	Automatic: 2,000 cycles @ 200% rated current Manual: 500 cycles @ 200% rated current
Interrupt Current Capacity	Per SAE J1625 and ABYC E-11
Vibration	10G MIL-STD-202 Method 204, Condition A
Mechanical Shock	100G MIL-STD-202 Method 213, Condition C
Dielectric Strength	MIL-STD-202 Method 301, 1500VAC min
Insulation Resistance	MIL-STD-202 Method 302, Condition B, 100 MΩ min
Weight (with mounting nuts)	PDLM : 129 grams max PDLA : 116 grams max

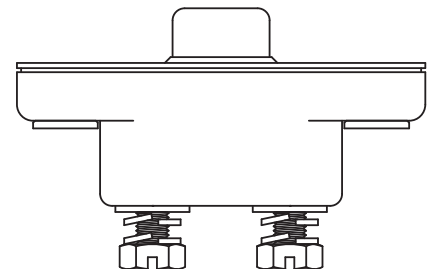

### TRIP CURVE - Approximate Time, Current Characteristics At 77°F (25°C)

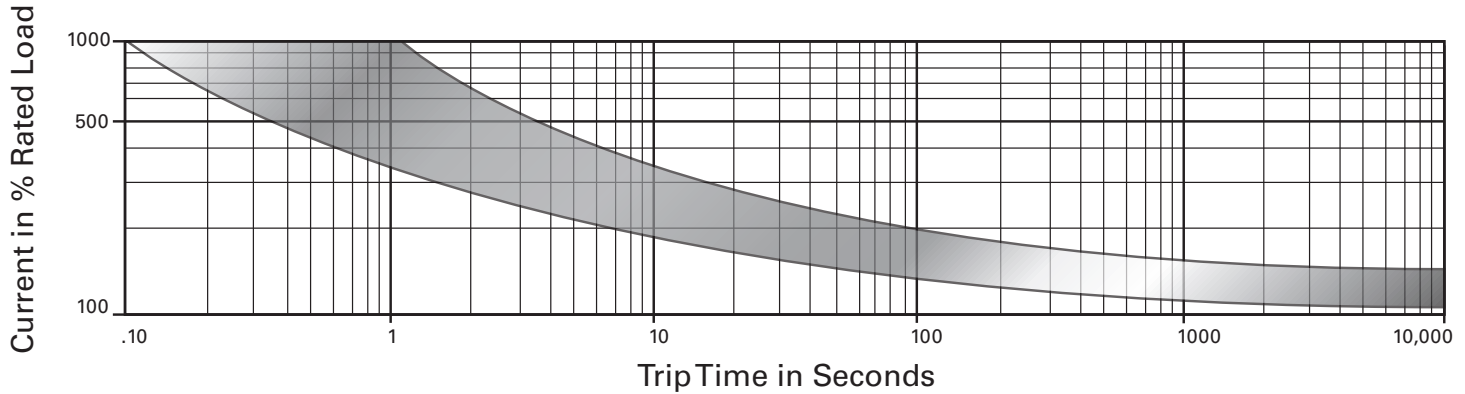

### DIMENSIONS - PDLM

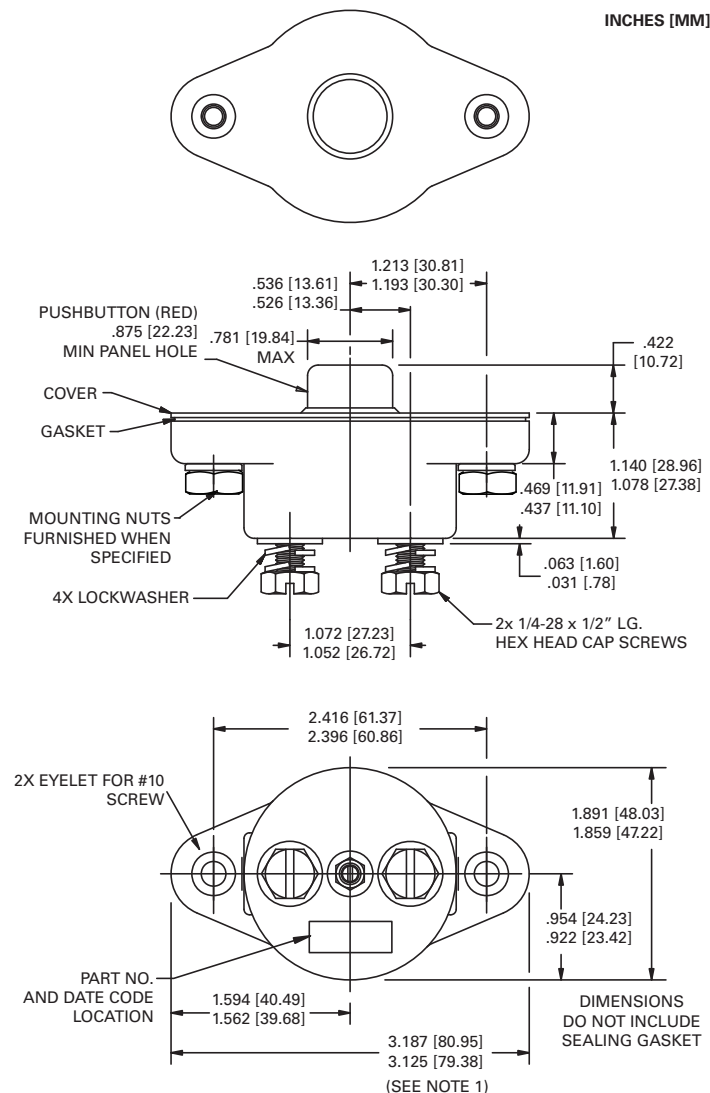

### DERATING CURVE

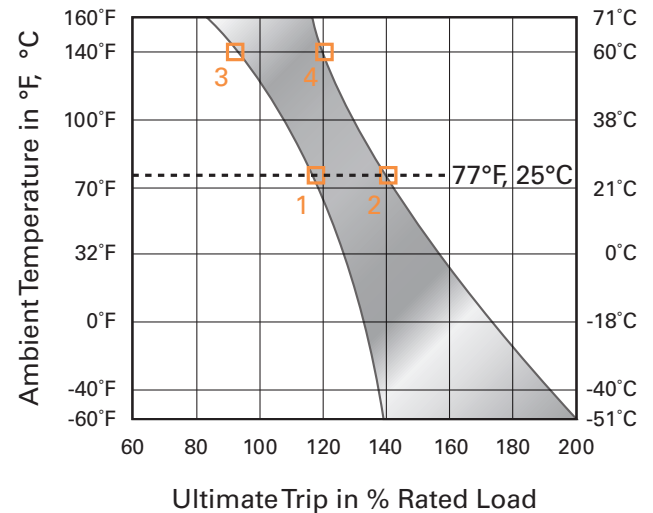

Performance characteristics are based on room temperature (77°F, 25°C). Consult Derating curve for ambient temperatures significantly higher or lower than standard room temperature.

Example: At 77°F (25°C) the device is calibrated to hold at 110% of rated current (1) and trip at 138% of rated current (2). At 140°F (60°C), the same device will hold at approximately 92% of rated current (3), and trip at approximately 120% of rated current (4).



# KLIXON® | PS Series (PSA, PSM)

## 2 to 35 Amp Precision Thermal Circuit Breaker

### FEATURES

- 30VDC, 2 to 35 Amps
- Available in manual and automatic reset options
- PSM meets CID A-A-55571/06 specifications
- PSA meets CID A-A-55571/05 specifications
- UL Recognized E36869

### DESCRIPTION

The KLIXON® PS series of breakers are designed to interrupt short circuits or overloads and combines trip-free protection with fast response time. The PS series thermal breaker is ideal for commercial and military vehicle equipment where precise ultimate trip characteristics are required.

### ORDERING INFORMATION

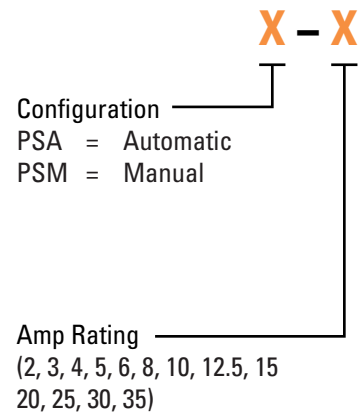

### PERFORMANCE CHARACTERISTICS

Calibration : 200% rated current, 77°F (25°C)	≤10A for 20 to 150 seconds >10A for 8 to 50 seconds
Ultimate Trip At 77°F (25°C)	Must hold 100%, Must trip 138%
Endurance	Automatic: 2,000 cycles @ 200% rated current Manual: 500 cycles @ 200% rated current
Interrupt Current Capacity	Per SAE J553, 600A
Vibration	10G MIL-STD-202 Method 204, Condition A
Mechanical Shock	100G MIL-STD-202 Method 213, Condition C
Dielectric Strength	MIL-STD-202, Method 301, 1500VAC min
Insulation Resistance	MIL-STD-202, Method 302, Condition B, 100 MΩ min
Weight	PSA : 30 grams max PSM : 32 grams max

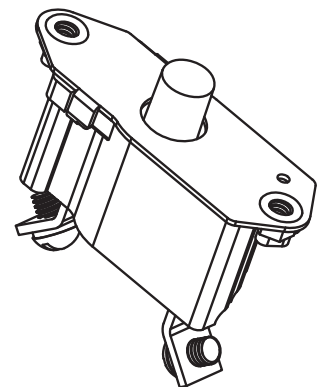



## TRIP CURVE - Approximate Time, Current Characteristics At 77°F (25°C)

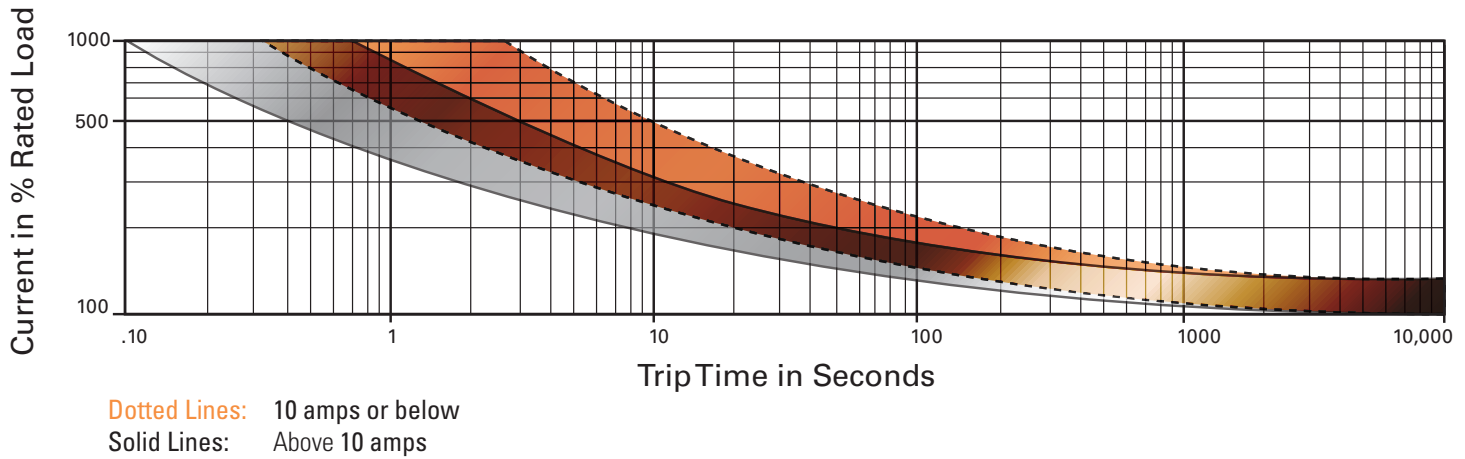

### DIMENSIONS - PSM (10 amps or less)

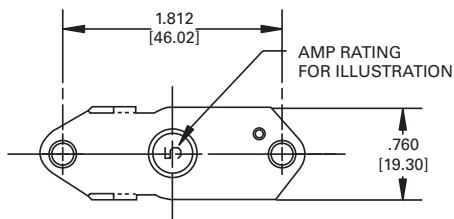

### DIMENSIONS - PSM (over 10 amps)

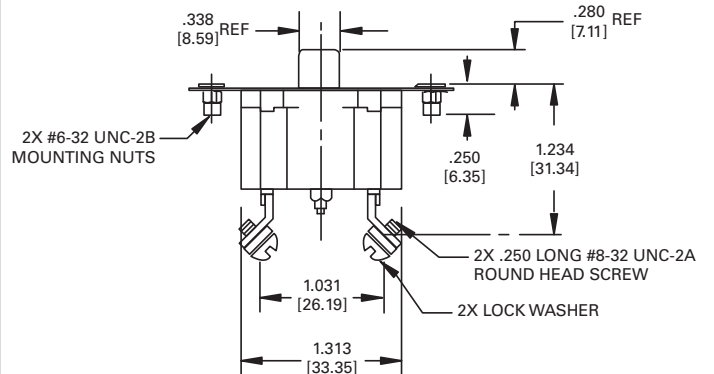
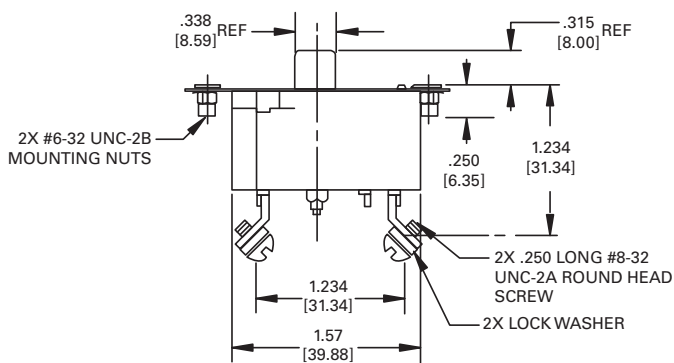
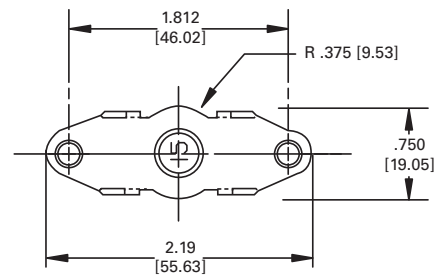



## KLIXON® | 9115 Series

### 15 to 30 Amp Precision Thermal Circuit Breaker

#### FEATURES

- 30VDC, 15 to 30 Amps
- Sealed assemblies, available in manual and automatic reset options
- Ignition protected SAE J1171 & CCC certified
- 9115-5 meets CID A-A-55571/01 specifications
- 9115-6 meets CID A-A-55571/02 specifications
- UL Recognized E36869

#### DESCRIPTION

The KLIXON® 9115 series of circuit breakers was designed for waterproof electrical systems of ordnance vehicles. The 9115 series is recommended for other mobile military and ground equipment, including trucks, tractors, graders, earth movers, fuel units, and amphibious as well as commercial vehicles. In addition to a complete sealed thermal element this series of thermal breakers has molded in terminals and are supplied with rubber connectors (shells).

#### ORDERING INFORMATION

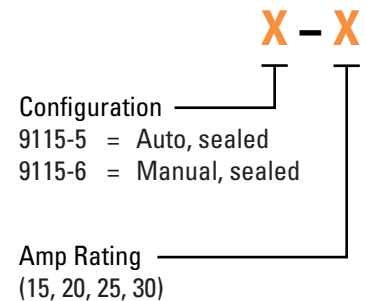

#### PERFORMANCE CHARACTERISTICS

Calibration : 200% rated current, 77°F (25°C)	8 to 50 seconds
Ultimate Trip At 77°F (25°C)	Must hold 100%, Must trip 138%
Endurance	Per SAE J553: Automatic: 2,000 cycles @ 200% rated current Manual: 500 cycles @ 200% rated current
Interrupt Current Capacity	Per SAE J553, 600A
Vibration	10G MIL-STD-202 Method 204, Condition A
Mechanical Shock	100G MIL-STD-202 Method 213, Condition C
Dielectric Strength	MIL-STD-202 Method 301, 1500VAC min
Insulation Resistance	MIL-STD-202 Method 302, Condition B, 100 MΩ min
Weight	9115-5 : 65 grams max 9115-6 : 76 grams max

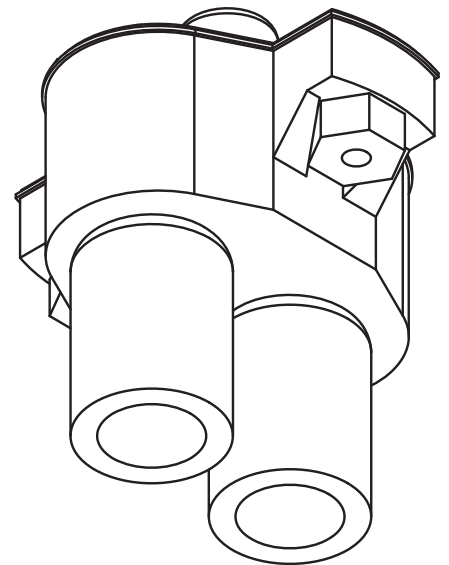

## TRIP CURVE - Approximate Time, Current Characteristics At 77°F (25°C)

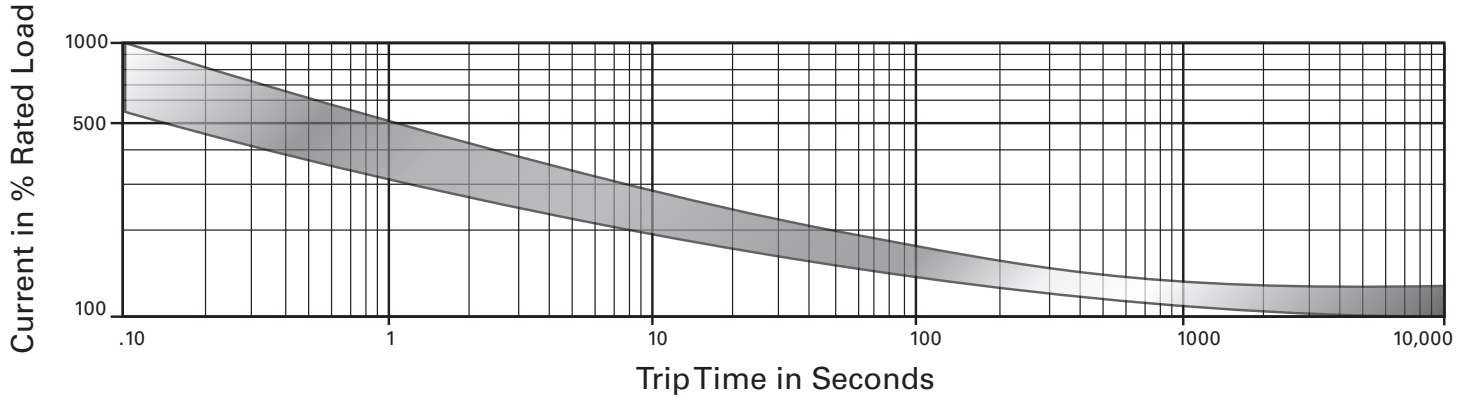

### DIMENSIONS - 9115-5

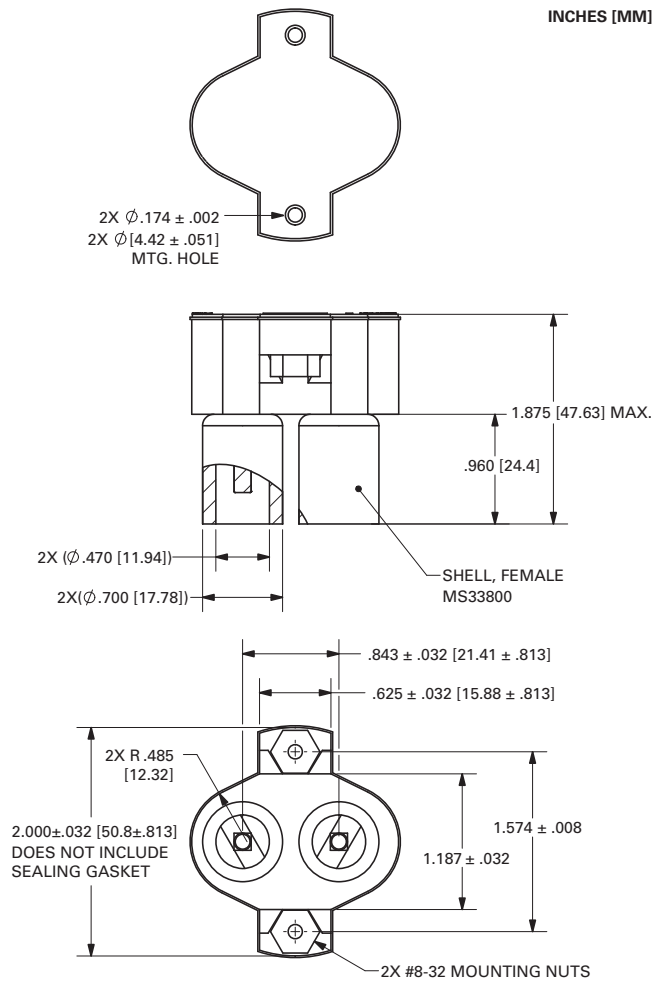

### DIMENSIONS - 9115-6

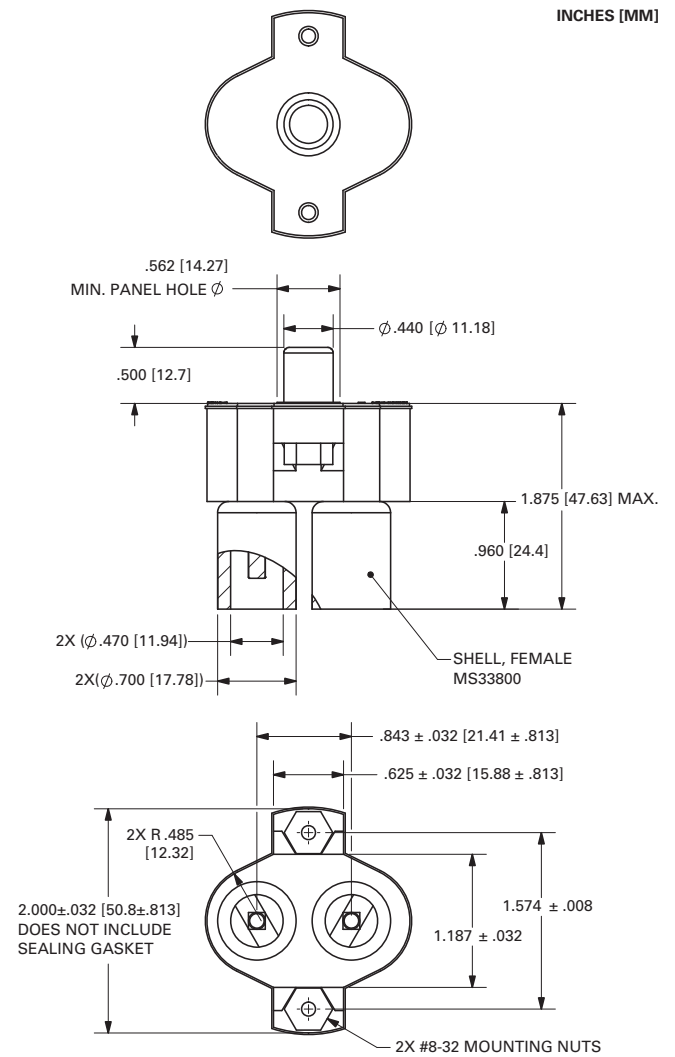

**Notes:**

1. Shell female MS33800 mates with MS27143 or MS27144.

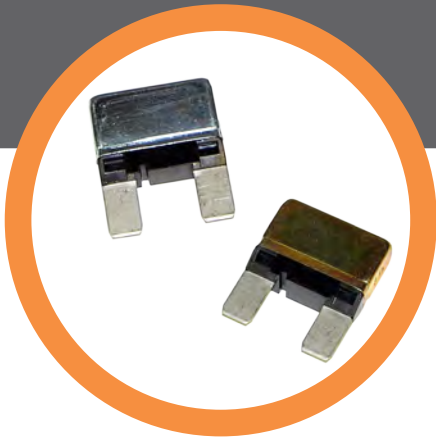

# KLIXON | MAXI BREAKER® Series

## Miniature Circuit Breakers

### FEATURES

- Available in SAE Type 1 (cycling) and SAE Type 2 (non-cycling)
- Multiple bimetallic resistivities available
- Heater wire wrapped around the bimetal keeps the protector open until power is removed (Type 2 only)

### DESCRIPTION

The MAXI BREAKER® series of circuit protectors are rated for use up to 125°C. This patented device is available both as a cycling (SAE Type 1) and non-cycling (SAE Type 2) device. Typical placement of the MAXI BREAKER® is under the hood fuse blocks or other areas of the vehicle that house a MAXI™ Blade Fuse\*. The MAXI BREAKER® protects against momentary overloads and eliminates the need for fuse replacement.

### SPECIFICATIONS

- Nominal Operating Voltage: 14 Volts DC
- Typical Voltage Drop at Operating Current: 200 mV max
- Current Rating: 10 to 50 amps @ 25°C (in 5 amp increments)
- Typical Ambient Temperature Range: -40°C to 125°C

### DIMENSIONS, mm (inches)

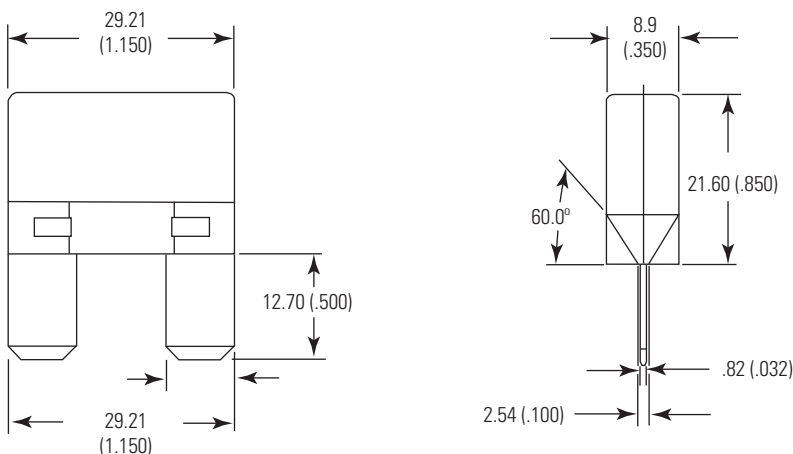

### CURVES

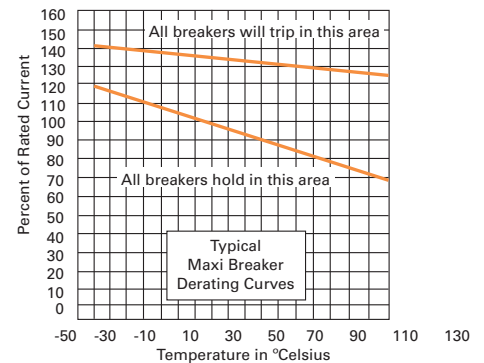
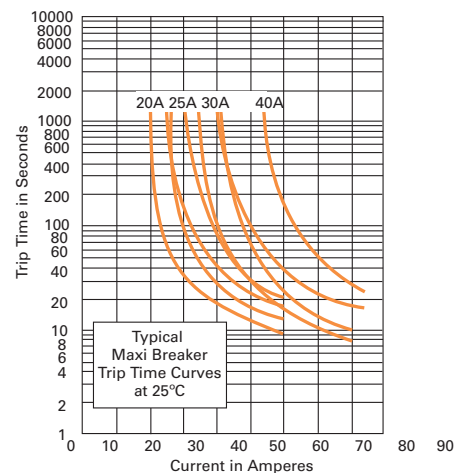

These curves are to be used only as a guide in selecting a protector for a particular application. Factors such as distance from the heat source and the method of mounting should be considered in selecting a protector. Final trip times are dependent upon terminal configuration and mounting in the application.

\* MAXI™ Blade Fuse is a trademark of Littelfuse®



# KLIXON<sup>®</sup> | EXT 200 Series

## Miniature Circuit Breakers

### FEATURES

- SAE Type 2 (non-cycling) device
- Multiple bimetallic resistivities available
- Multiple terminal configurations available
- Metal encased

### DESCRIPTION

The EXT 200 Series of mini remote reset circuit breakers are commonly designed for 12 Volt DC wiring harness protection. The device is ideal for the protection of circuits that may experience momentary overloads and is often chosen as an alternative to fuses, where nuisance replacement can be an inconvenience. The EXT 200 can be mounted in the fuse block or elsewhere within the wiring harness. This bimetallic device is sensitive to both over-current and over-temperature fault conditions.

### SPECIFICATIONS

- Nominal Operating Voltage: 12 Volts DC
- Typical Voltage Drop at Operating Current: 200 mV max
- Current Rating: 5 to 35 amps @ 25°C (in 5 amp increments)
- Typical Ambient Temperature Range: -40°C to 85°C

### CURVES

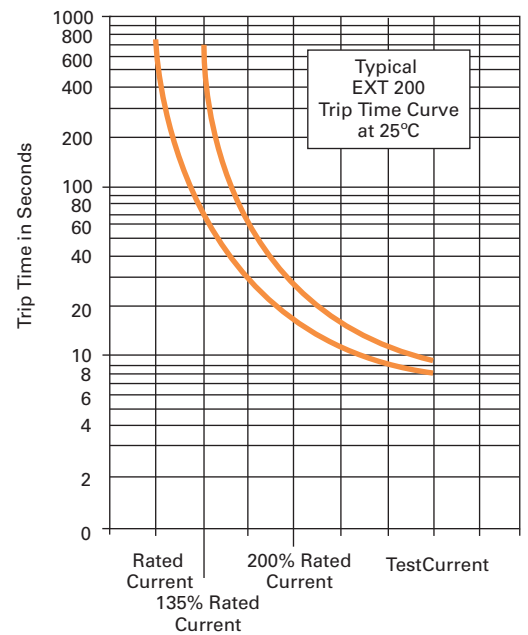

These curves are to be used only as a guide in selecting a protector for a particular application. Factors such as distance from the heat source and the method of mounting should be considered in selecting a protector. Final trip times are dependent upon terminal configuration and mounting in the application.

### DIMENSIONS, mm (inches)

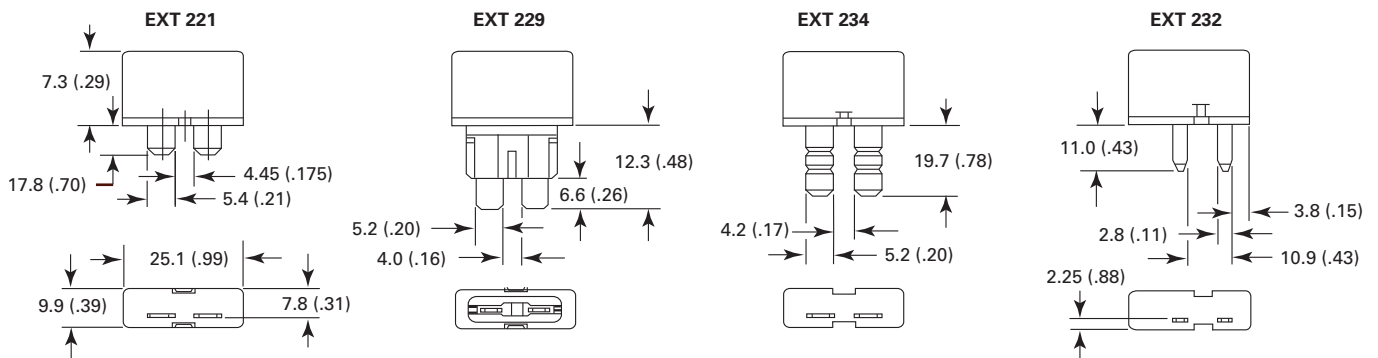

## GLOSSARY OF TERMS

<b>Amp Rating</b>	The nominal electrical current in amperes that the breaker will carry at room temperature without tripping
<b>Automatic Reset</b>	A device that opens by a combination of overcurrent and elevated temperature, with a design feature that allows the breaker to cycle or continuously self reset.
<b>Circuit Breaker</b>	A device designed to carry a specific value of current and automatically open a circuit upon overloads or short circuits.
<b>Dielectric Strength</b>	A device's ability to withstand a deliberate application of pre-determined over-voltage for a specified time.
<b>Dielectric Withstanding Voltage</b>	The maximum voltage that a switch can withstand between specified points without leaking current exceeding a specified value.
<b>Endurance</b>	Refers to the longevity cycling of a circuit breaker under less than direct short conditions
<b>Insulation Resistance</b>	The resistance offered by the insulating members of a component part to direct voltage tending to produce a leakage current through or on the surface of these members. Insulation resistance should not be considered the equivalence of dielectric withstanding voltage. Also: Measures the resistance of the insulating member of the device to a target voltage.
<b>Manual Reset</b>	A device that opens by a combination of overcurrent and elevated temperature, and remain open until manually reset into a conducting state.
<b>Maximum Ultimate Trip</b>	Current rating at which breaker must trip within a certain period (usually 1 hour) at a specified temperature.

<b>Minimum Ultimate Trip</b>	Current rating at which breaker will not trip within a certain period (usually 1 hour) at a specified temperature.
<b>Switchable</b>	A design feature that allows a switchable circuit breaker to function as a conventional manual reset circuit breaker and also has a mechanism, which when exercised at the discretion of the user, permits opening of the breaker internal circuit to stop current flow. The breaker is reset to its normal condition by the manual rest function, whether tripped unattended by a real fault condition or by the user.
<b>Thermal Circuit Breaker</b>	A circuit breaker that senses a current overload based on thermal heating of the sensing element.
<b>Thermal Derating</b>	The effect of ambient temperature on the trip characteristics of the breaker. For example, as ambient temperature increases, the amount of current required to trip the breaker decreases.
<b>Time-Current Curve</b>	An approximate graph showing the minimum and maximum time a specific breaker will trip at various degrees of overload.
<b>Trip Free</b>	A design feature that makes it impossible to hold the breaker closed against an overload.
<b>UL</b>	Underwriters Laboratory
<b>Voltage Drop</b>	The voltage decrease across the breaker due to internal resistance of the device.
<b>Weatherproof</b>	Circuit breakers designed such that if immersed or submerged in fluid (for example, water) no fluid shall infiltrate the internal cavities or workings of the circuit breaker.

**ABOUT SENSATA TECHNOLOGIES**

Sensata Technologies provides leaders in the automotive, appliance, aircraft, industrial, HVAC/R, over-the-road truck, heavy vehicle, bus, RV, marine, telecom and datacom global markets with sensing, protection and control solutions. Our mission is to improve safety, efficiency and environmental protection for millions of people worldwide.

Sensata Technologies is headquartered in Attleboro, Massachusetts in the United States and has business and manufacturing centers and sales offices throughout the world.

**THE SUPPLIER YOU WANT. THE PARTNER YOU NEED.**

At Sensata Technologies we do all we can to ensure your satisfaction. We apply our unsurpassed experience and expertise to focus on your needs. We adhere to the highest technical, manufacturing and testing standards. Our experts work with you to ensure the quality and precision it takes to meet the most demanding application requirements. No wonder a world of businesses relies on the more than 1 billion sensor, protection and control devices we manufacture each year to optimize our customers' own leading-edge technologies.

**WE DO IT ALL FOR YOU.**

We are dedicated to being our customers' first choice – no matter where in the world you are located. We do this by:

- Offering rugged designs and in-house testing facilities to ensure consistent quality
- Locating business centers close to your markets in every region of the world
- Consolidating manufacturing in large Make sites in cost-effective locations
- Partnering with those setting the latest standards in industrial and automotive system performance, safety and emission control

**SAFETY, PERFORMANCE, RELIABILITY**

You will find Sensata products wherever increased safety, performance and reliability are required and where improved machine productivity and efficiency are desired. You will find our products in an endless number of applications including HVAC and refrigeration, transportation, aircraft, trucks, buses, trains, datacom and telecom, construction, mining, agriculture, boats, recreational vehicles and material handling equipment. Our products are also found in compressors, pumps, hydraulics, pneumatics, process control and factory automation equipment, alternative fuel systems, communication towers and much more.

**MANUFACTURING PRODUCTS TO THE HIGHEST STANDARDS.**

Sensata's manufacturing and technology centers are ISO / TS16949 and ISO 14001 certified throughout the world.

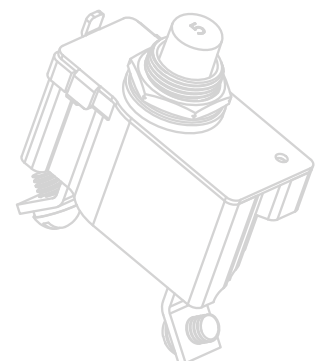
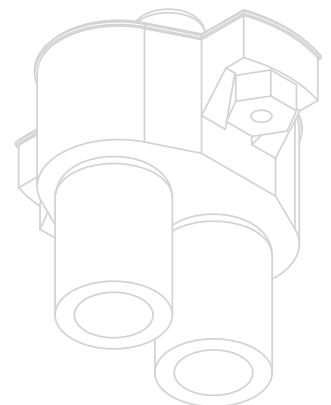
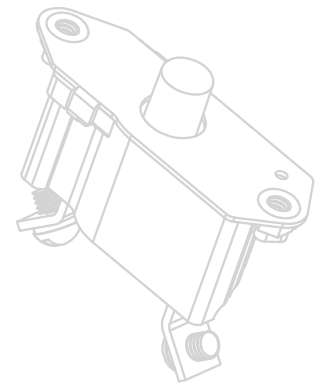
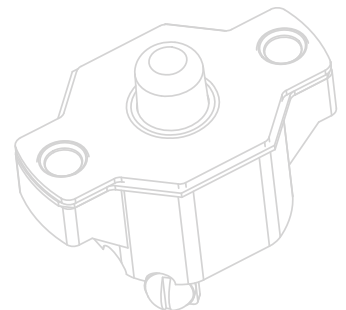

---

<http://www.sensata.com/>

**BUSINESS CENTER**

**Sensata Technologies Inc.**  
529 Pleasant Street  
Attleboro, MA 02703, USA  
Phone: +1 508-236-3800  
Fax: +1 508-236-2349



**Sensata**  
Technologies

©2013 Sensata Technologies, Inc. All rights reserved worldwide. Printed in USA, revised April 2013.

Important Notice: Sensata Technologies reserves the right to make changes to, or to discontinue, any product or service identified in this publication without notice. Before placing orders, users should obtain the latest version of the relevant information to verify that the information being relied upon is current.

Sensata Technologies assumes no responsibility for customers' product designs or applications. Users must determine the suitability of the Sensata device described in this publication for their application, including the level of reliability required. Many factors beyond Sensata's control can affect the use and performance of a Sensata product in a particular application, including the conditions under which the product is used and the time and environmental conditions in which the product is expected to perform. As these factors are uniquely within the user's knowledge and control, it is essential that the user evaluate the Sensata product to determine whether it is fit for a particular purpose and suitable for the user's application.

**The World Depends on Sensors and Controls**

Sensata Technologies products are sold subject to Sensata's Terms and Conditions of Sale which can be found at: [www.sensata.com/terms.htm](http://www.sensata.com/terms.htm)